

Amphenol

High Speed Solutions

ENABLING THE ELECTRONICS REVOLUTION

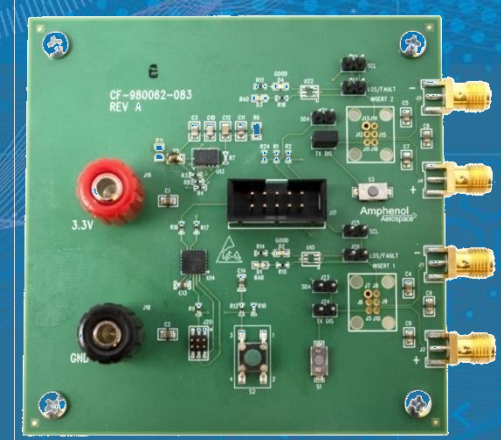

Amphenol FiberQuad Performance Data

Table of Contents

- FiberQuad Design
- FiberQuad BER/EYE at 100°C
- FiberQuad BER/EYE at 85°C
- FiberQuad BER/EYE at 23°C
- FiberQuad BER/EYE at -40°C
- FiberQuad BER/EYE at -55°C
- BER Summary Across Temperature
- FiberQuad SDI Testing at 100°C
- FiberQuad SDI Testing at 85°C
- FiberQuad SDI Testing at 23°C
- FiberQuad SDI Testing at -40°C
- FiberQuad SDI Testing at -55°C
- SDI Testing Summary

The logo features the word "Amphenol" in a large, bold, white sans-serif font. Above the letters "m", "p", and "h" are horizontal lines of binary code (0s and 1s). The background is a vibrant blue with a grid pattern and various abstract digital graphics, including circular patterns and flowing lines.

High Speed Solutions

ENABLING THE ELECTRONICS REVOLUTION

Amphenol FiberQuad Design

CF-170900-034 (Transmitter) Drawing

TOSA CONTACT I/O CHART	
PIN ID	FUNCTION
1	DISABLE
2	3.3VDC
3	GND
4	FAULT
5	INPUT-
6	INPUT+

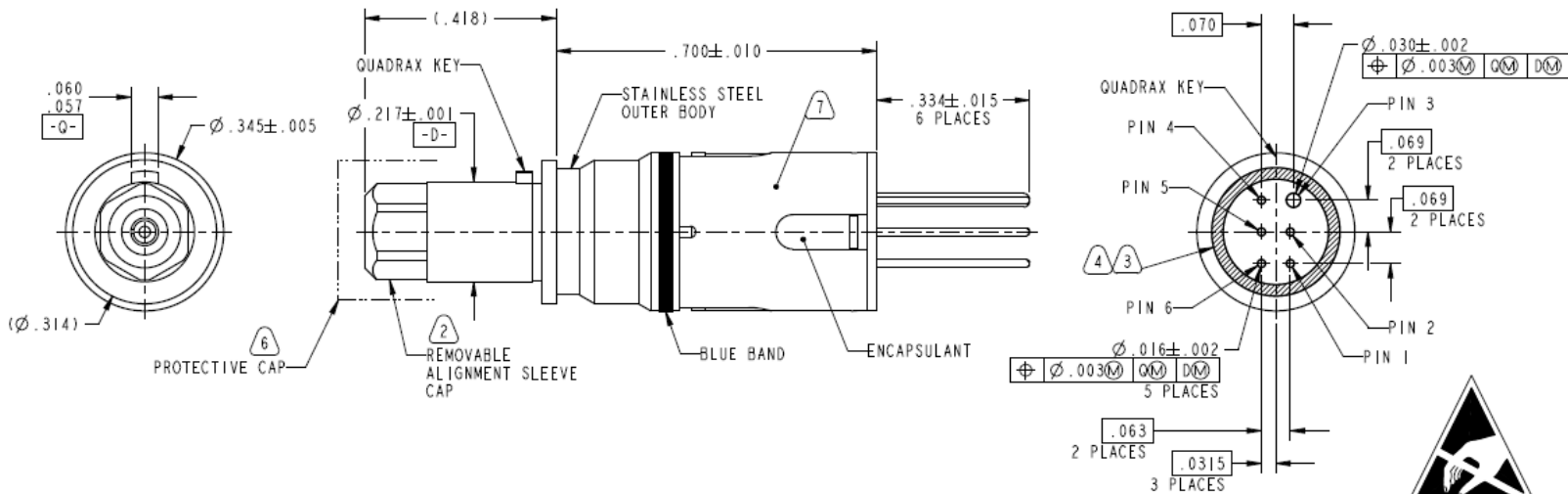

ATTENTION
 OBSERVE PRECAUTIONS
 FOR HANDLING
 ELECTROSTATIC
 SENSITIVE
 DEVICES

CF-170900-034 (Transmitter) Circuit

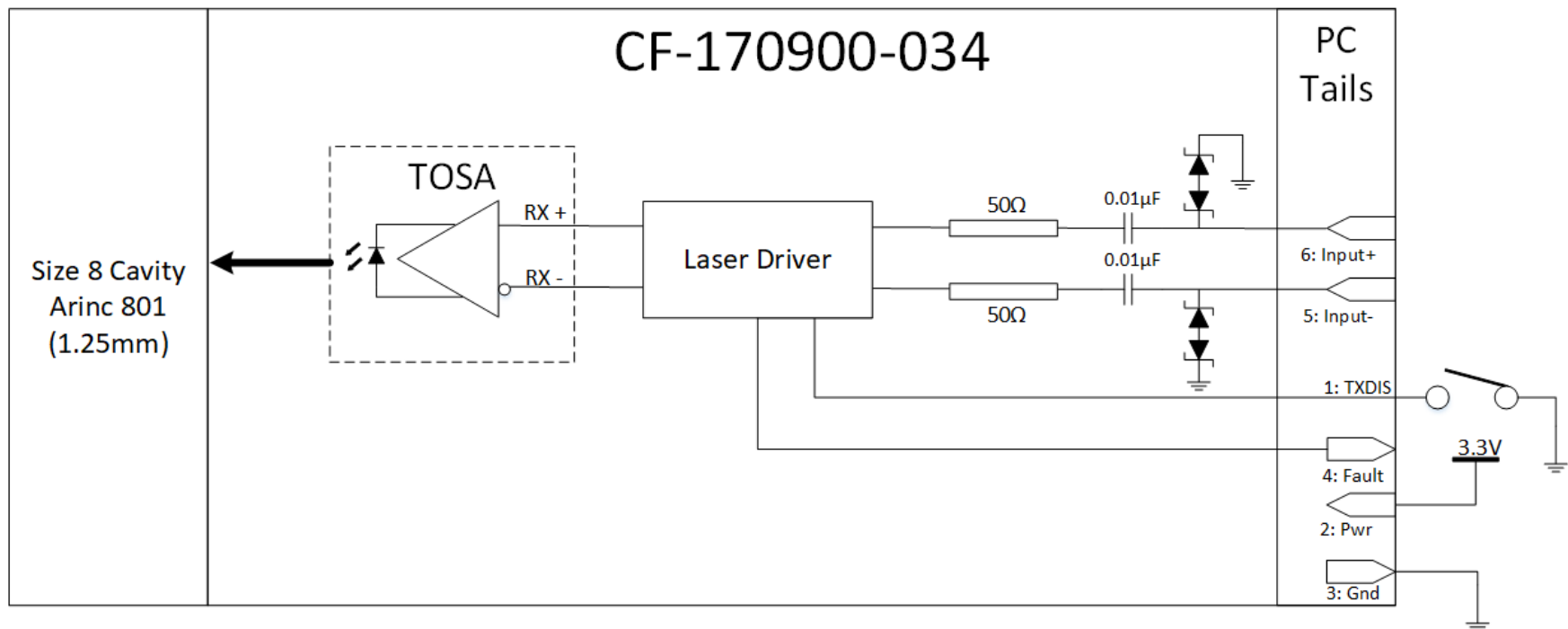

CF-170900-035 (Receiver)

ROSA CONTACT I/O CHART	
PIN ID	FUNCTION
1	GND
2	3.3VDC
3	GND
4	LOS
5	OUTPUT-
6	OUTPUT+

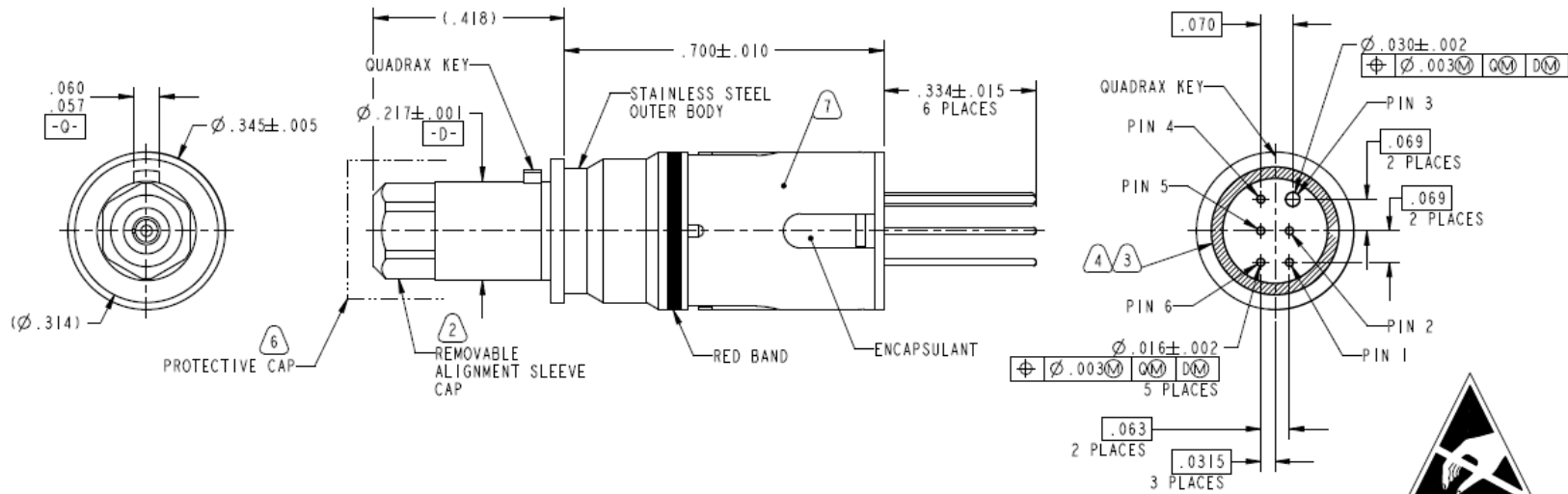

ATTENTION
OBSERVE PRECAUTIONS
FOR HANDLING
ELECTROSTATIC
SENSITIVE
DEVICES

CF-170900-035 (Receiver) Circuit

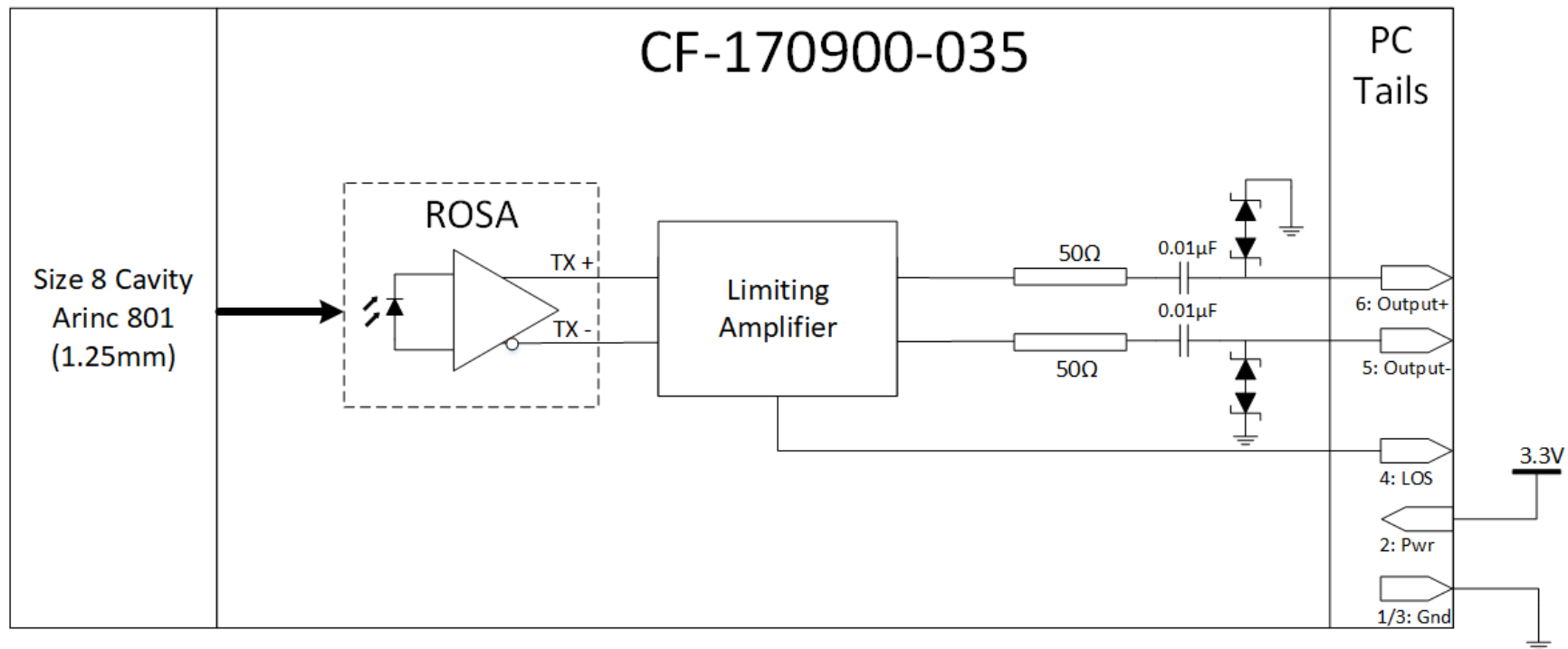

Amphenol

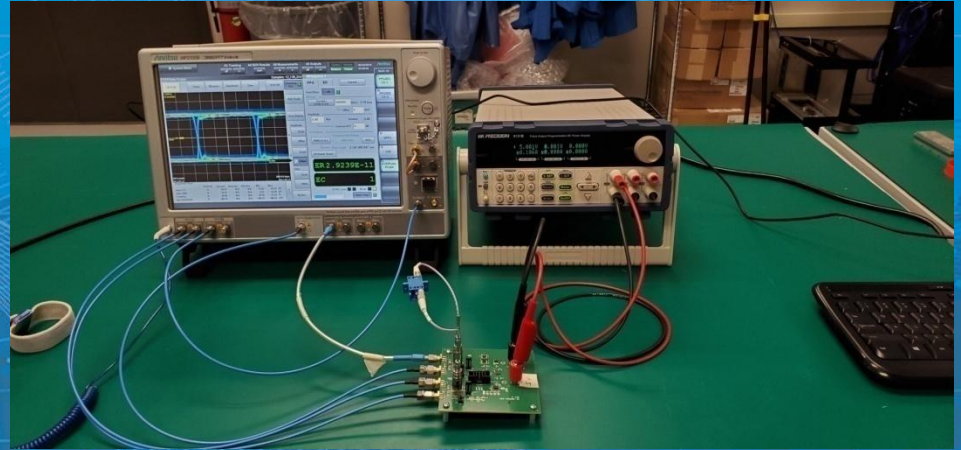

ENABLING THE ELECTRONICS REVOLUTION

FiberQuad Performance Testing BER and Eye Diagrams

Testing Purpose

- To characterize the performance of Amphenol High Speed Solutions CF-170900-034 and CF-170900-035 FiberQuad contact under a variety of conditions including speed and attenuation
 - Bit error rates and eye diagrams were captured simultaneously
- To test FiberQuad contacts at slower and higher speeds than the components within are rated for
- Validate performance of FiberQuad CF-980062-083 test board
- Validate performance of FiberQuad plug adapters

Ratings of Components within -034/035

CF-170900-034

- Transmit Optical Subassembly
 - Up to 4.25 Gbps
- Electronics
 - 155Mbps to 4.25 Gbps

CF-170900-035

- Receive Optical Subassembly
 - 155Mbps to 4.25 Gbps
- Electronics
 - 155Mbps to 4.25 Gbps

Test Setup Block Diagram

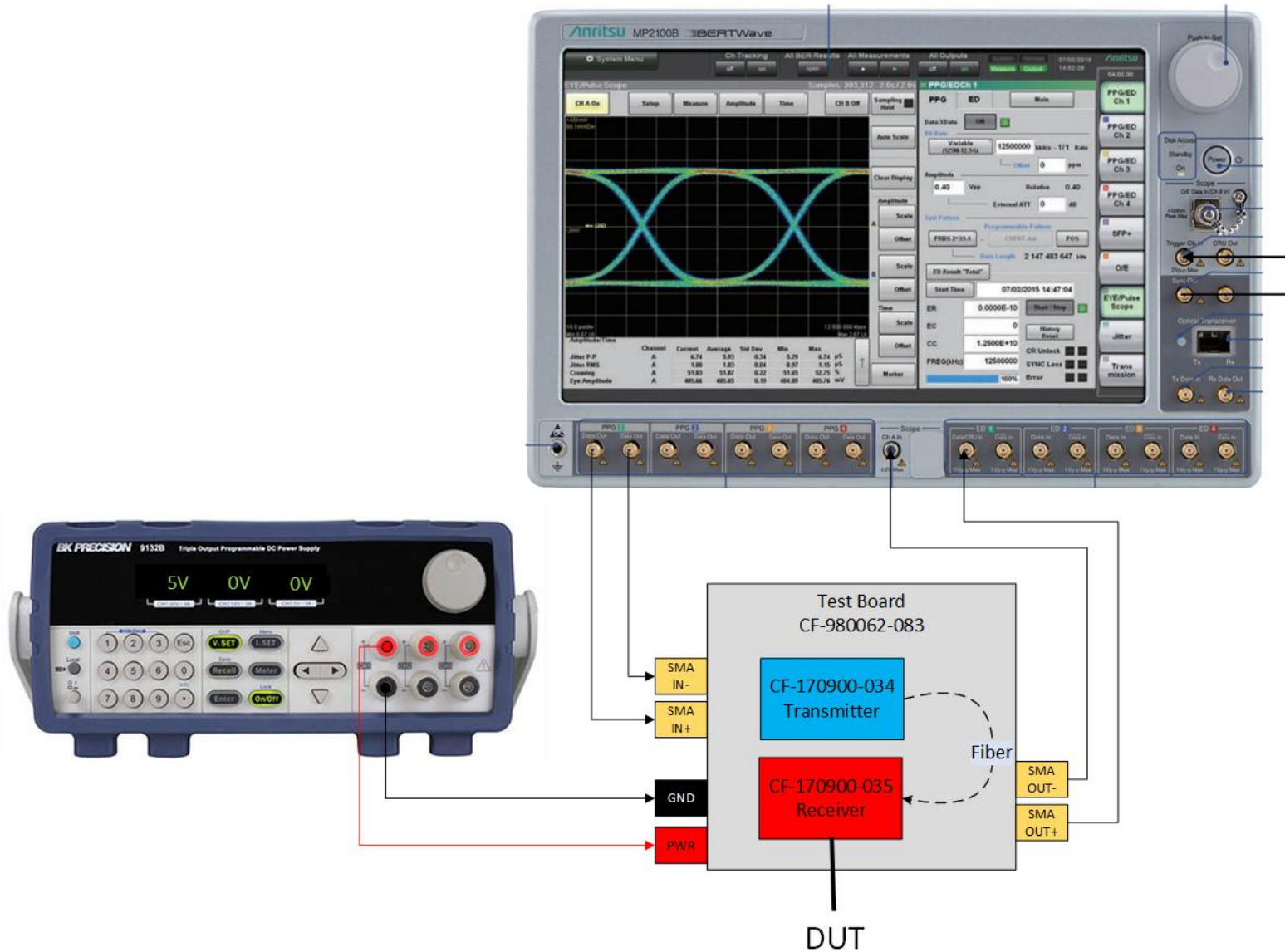

Test Setup (without Attenuator)

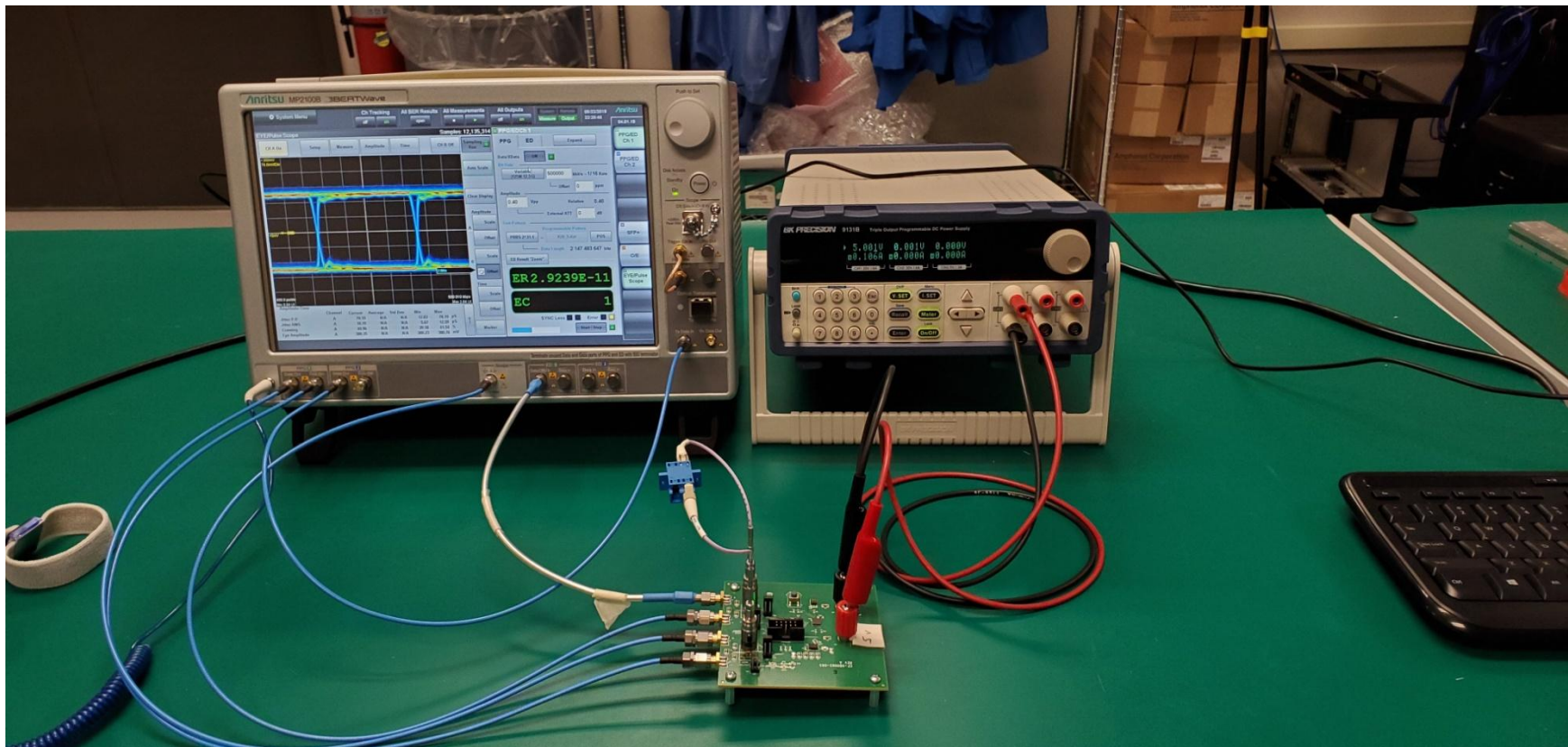

Test Setup (with Attenuator)

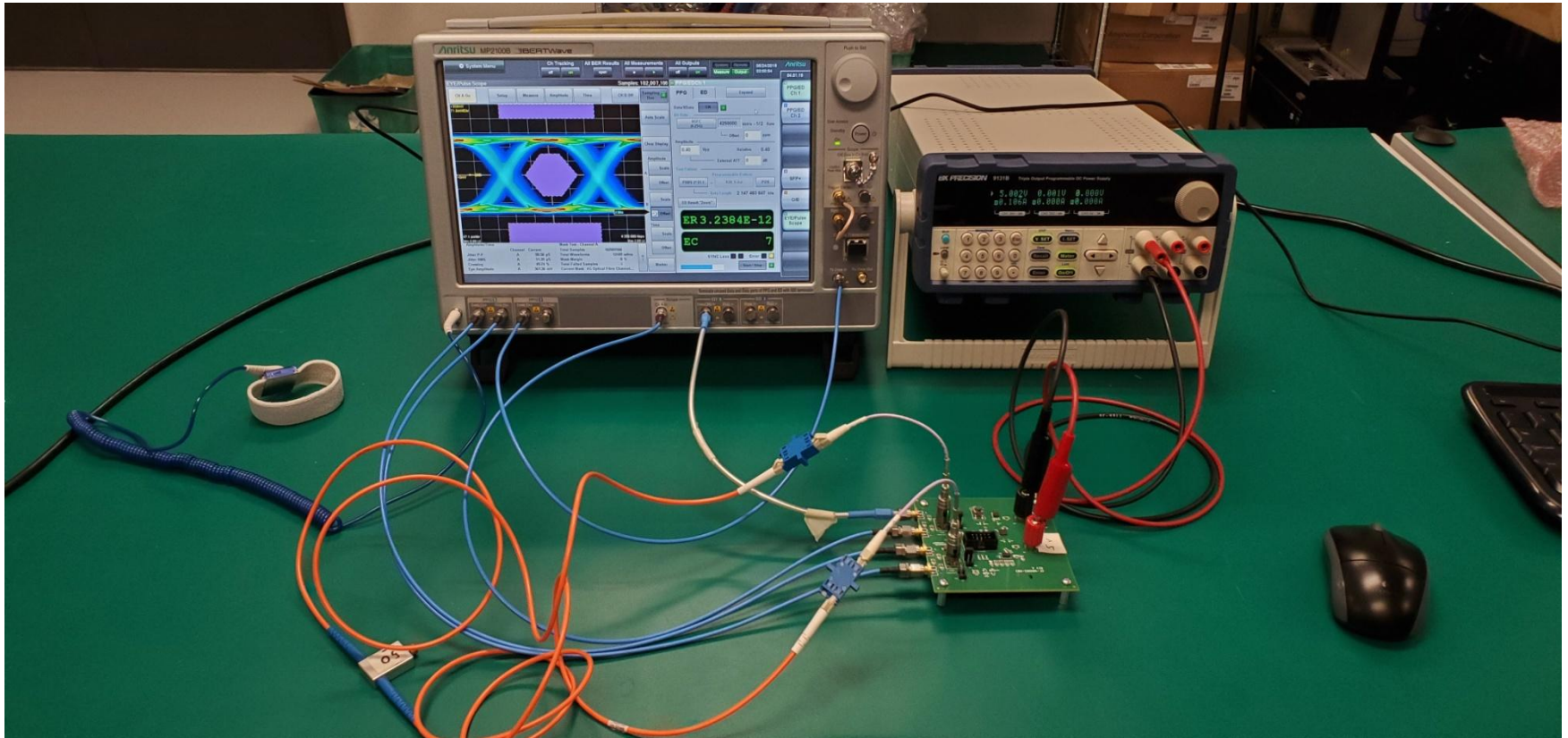

Test Setup – Test Board

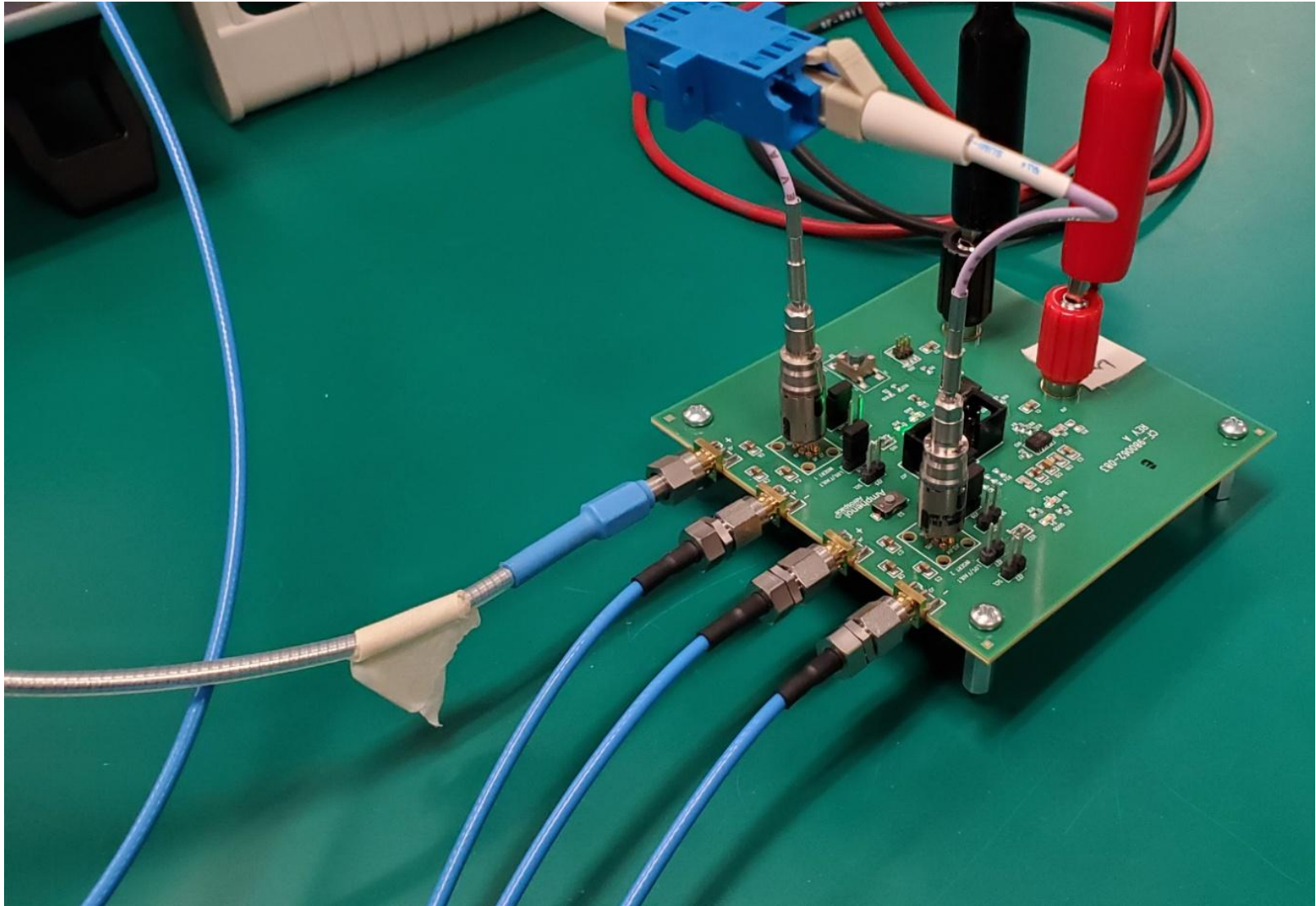

Test Setup/Conditions

- Ambient temperature 23°C
- PRBS 2³¹-1 Pattern
- With and without optical attenuation using the following data rates:
 - 125 Mbps
 - 500 Mbps
 - 1.25 Gbps (using a GbE mask)
 - 4.25 Gbps (using a FibreChannel mask)
 - 6.00 Gbps
 - 8.50 Gbps (using a FibreChannel mask)
- The optical attenuator was set such that the receiver received -15dBm of optical power from the transmitter
- Duration of each test was roughly 10 minutes
- For every test performed one error was purposely injected in order to have a BER

125Mbps No Attenuation

Eye Diagram

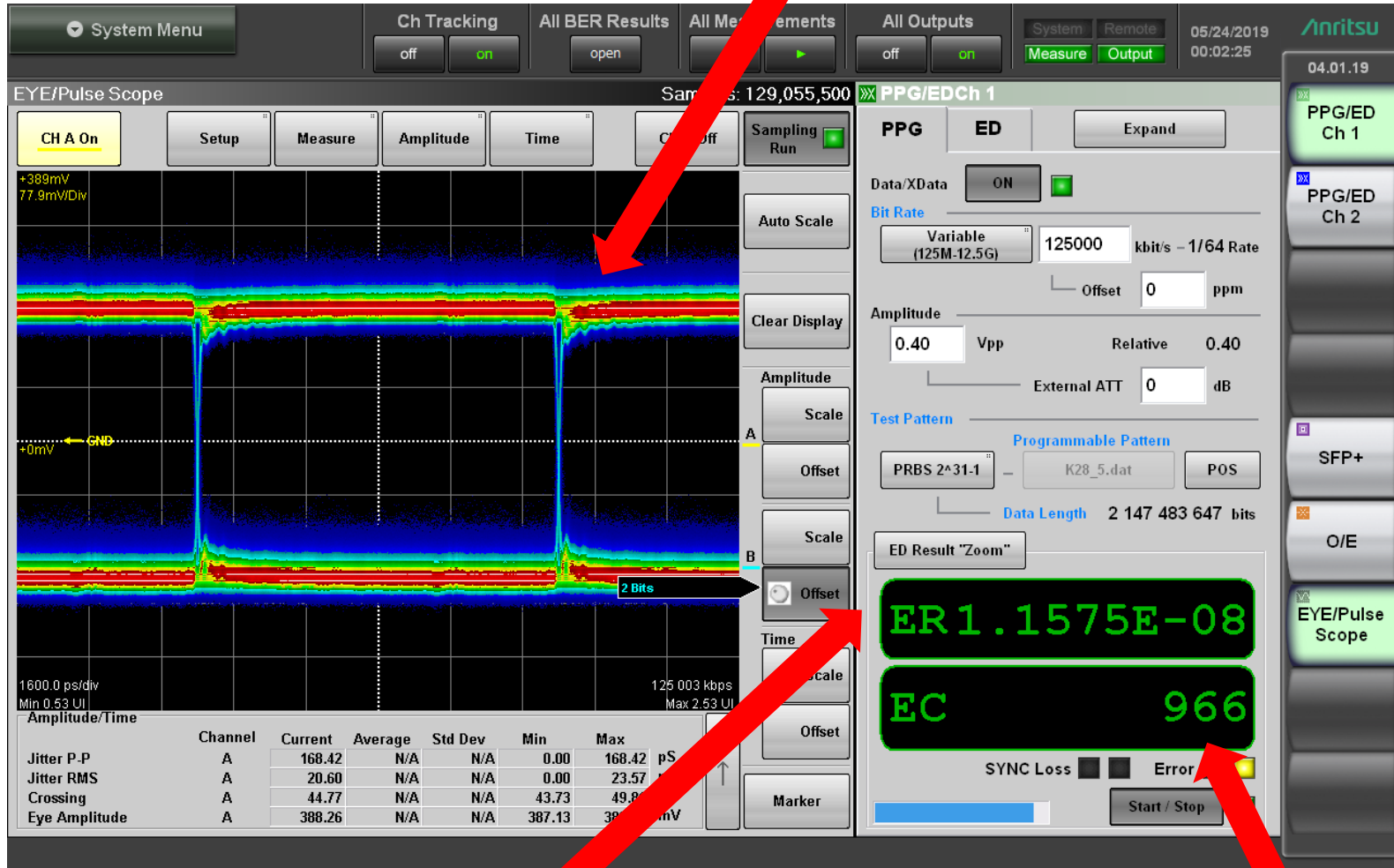

23°C

Bit Error Rate

Bit Error Count

125Mbps with Optical Attenuation

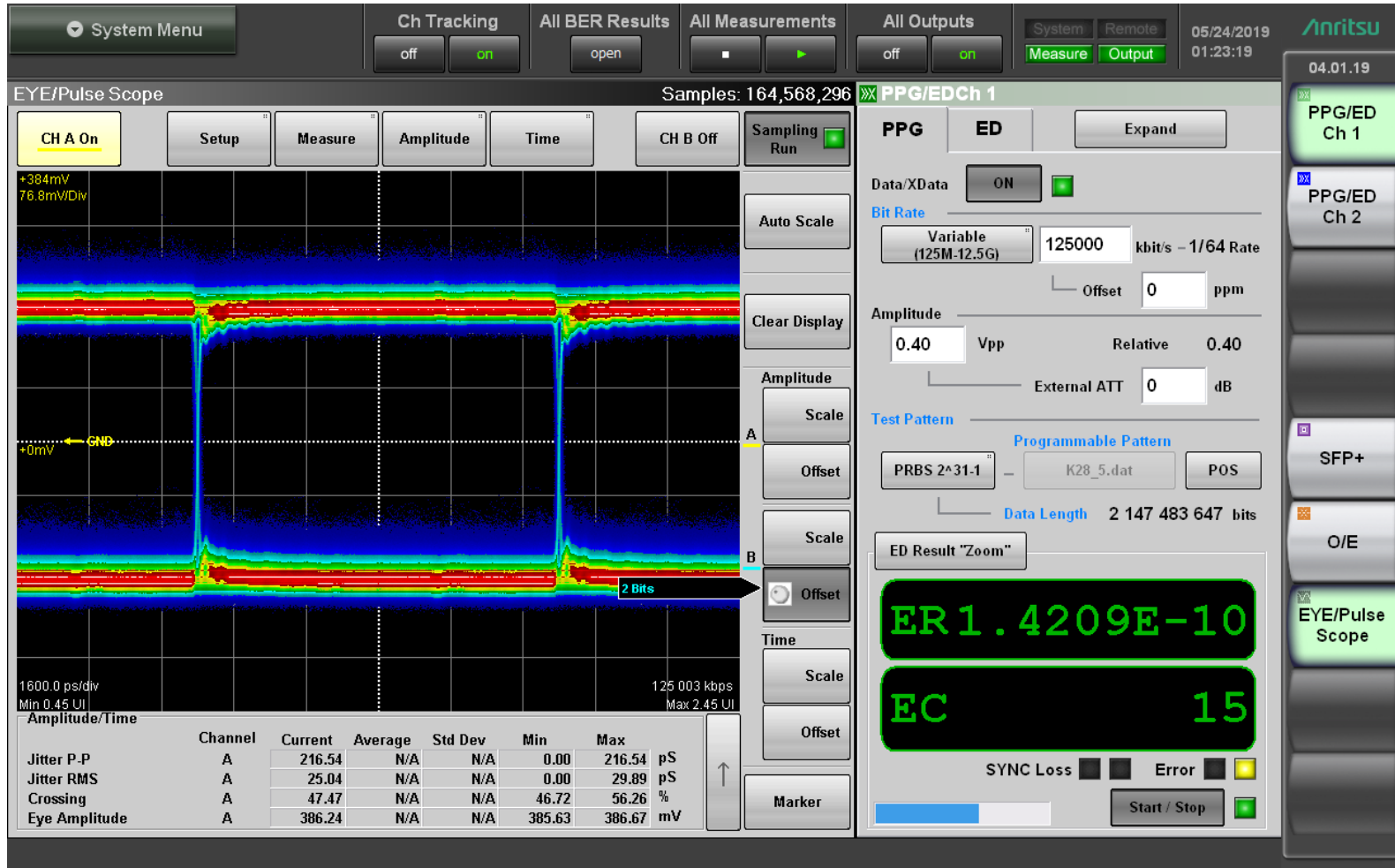

23°C

500Mbps No Attenuation

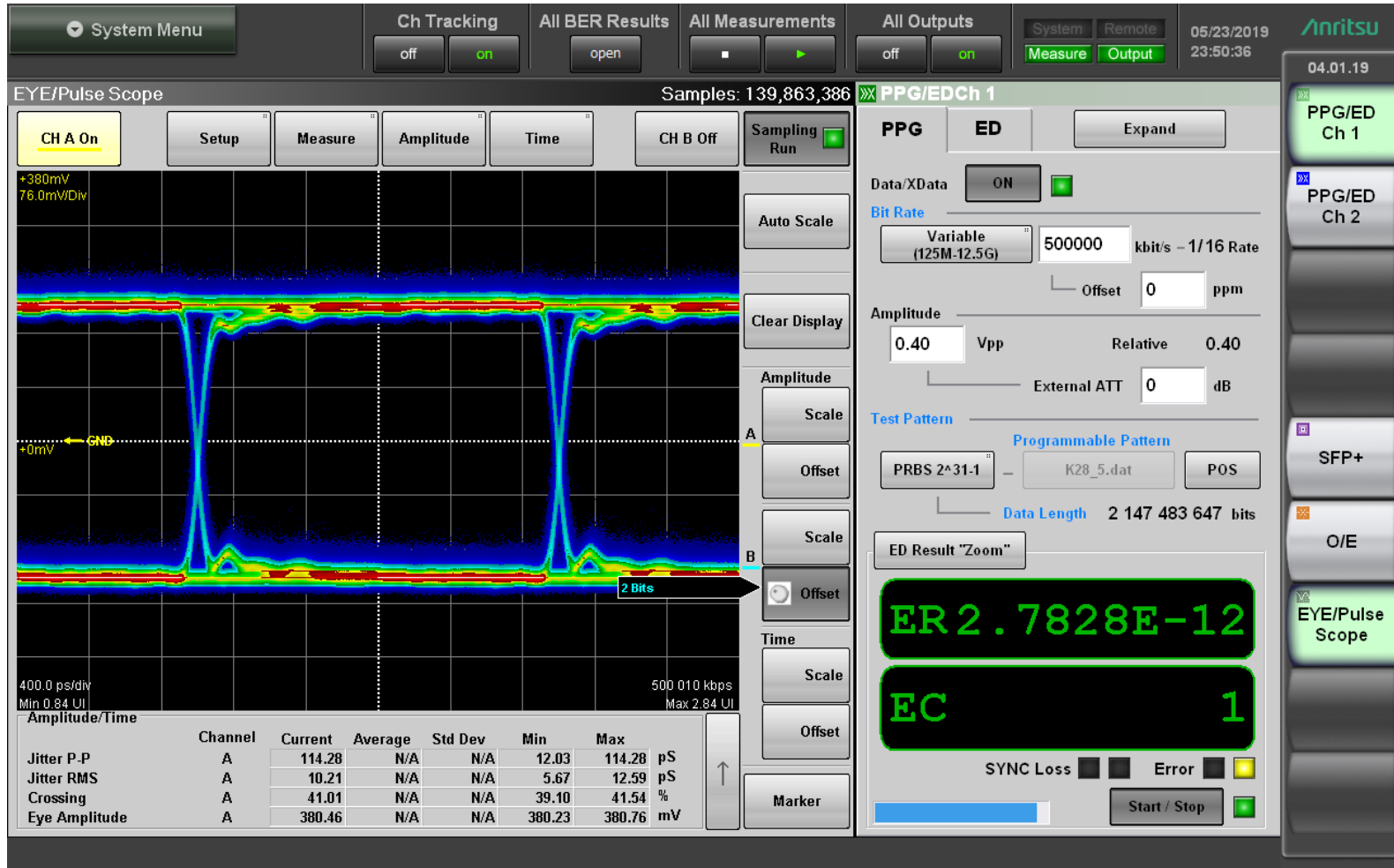

23°C

500Mbps with Optical Attenuation

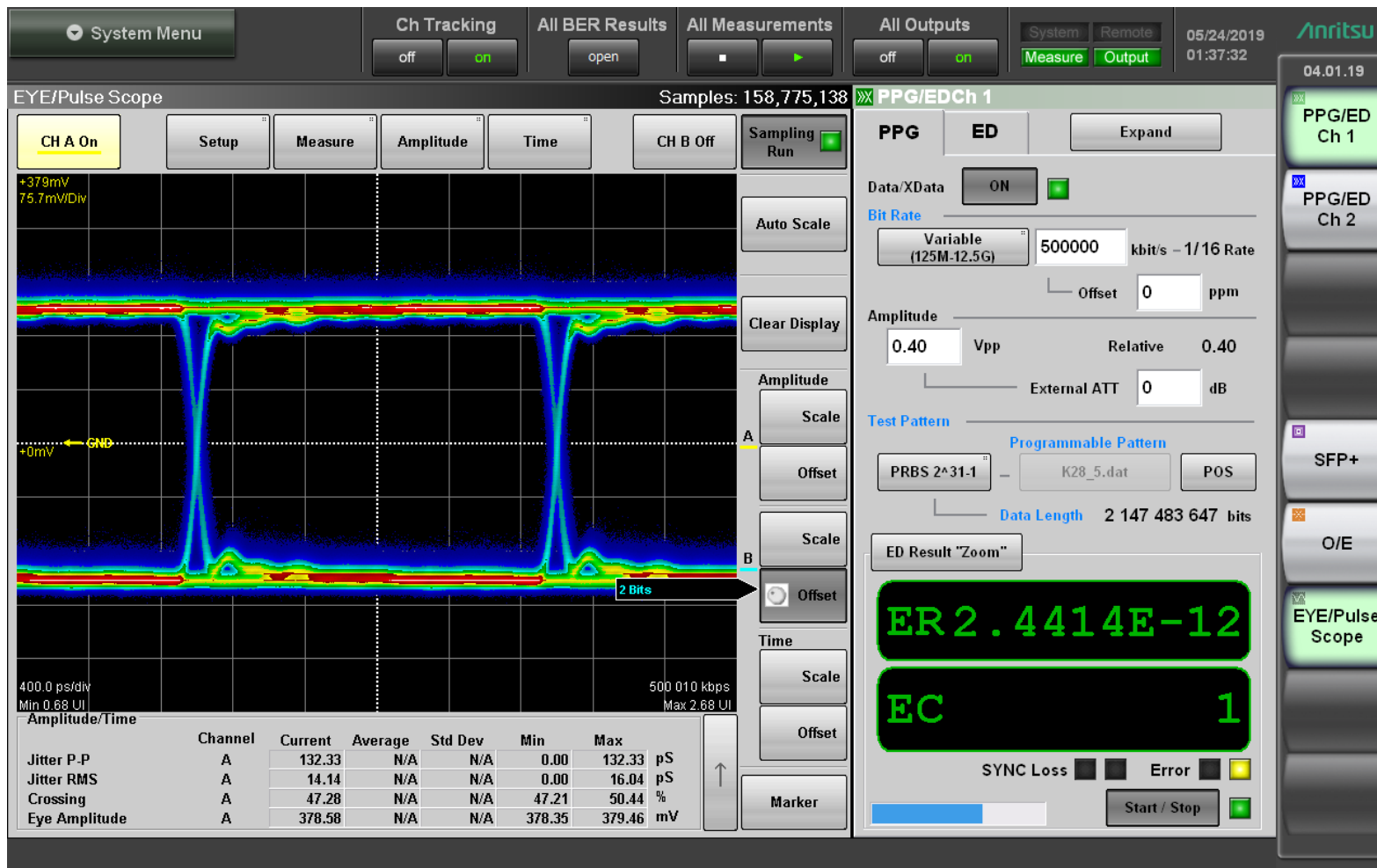

23°C

1.25Gbps No Attenuation

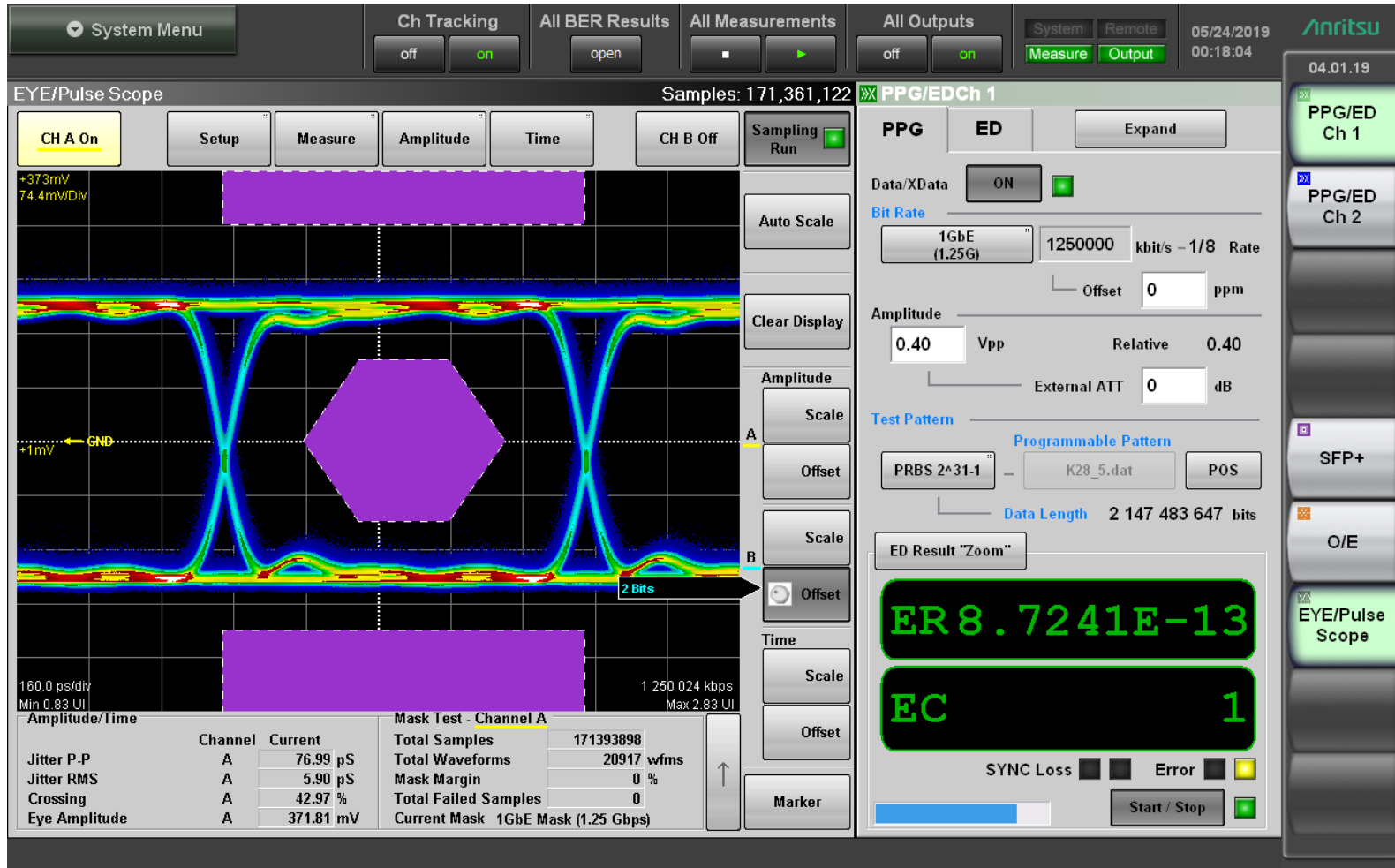

23°C

1.25Gbps with Optical Attenuation

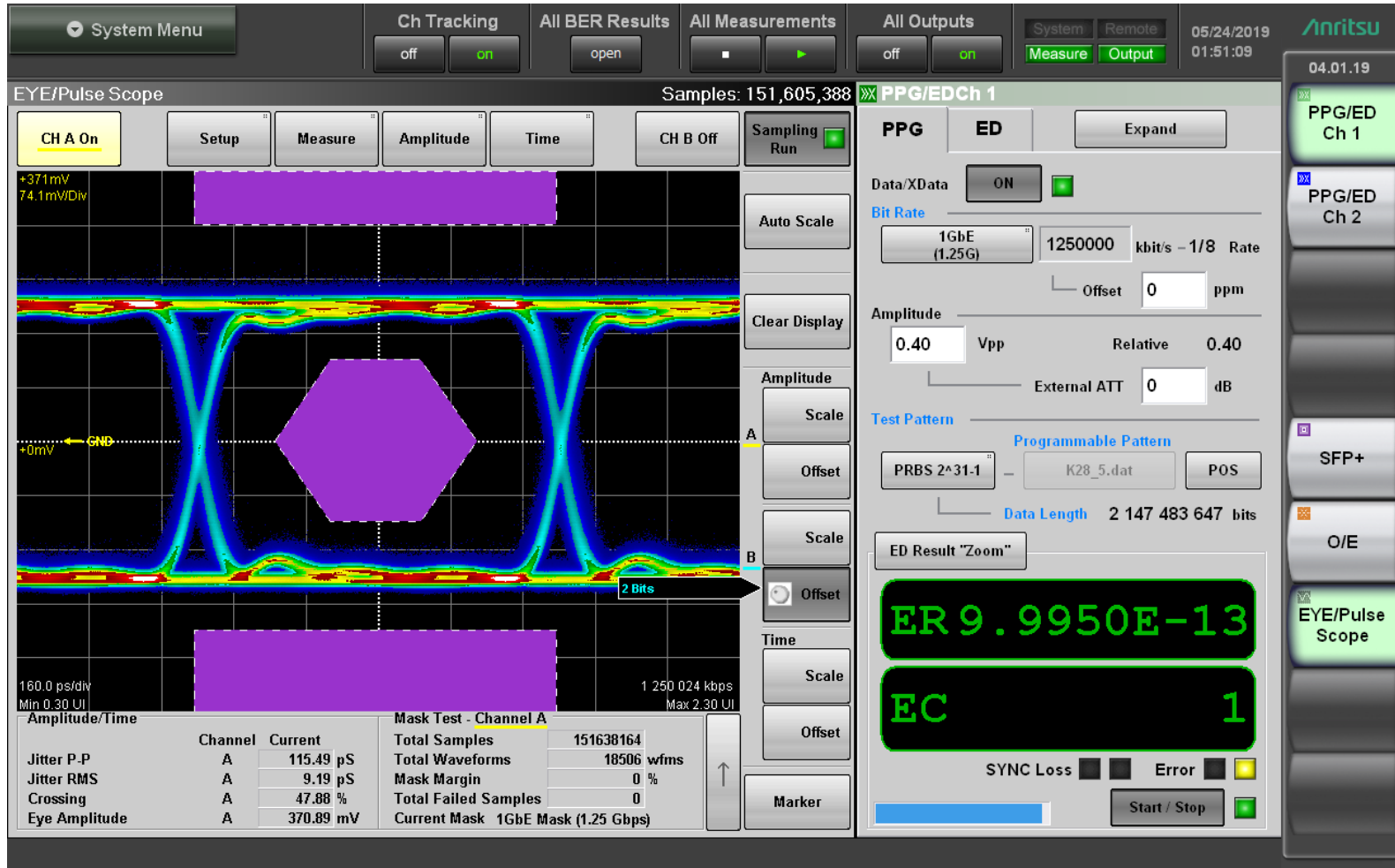

23°C

4.25Gbps No Attenuation

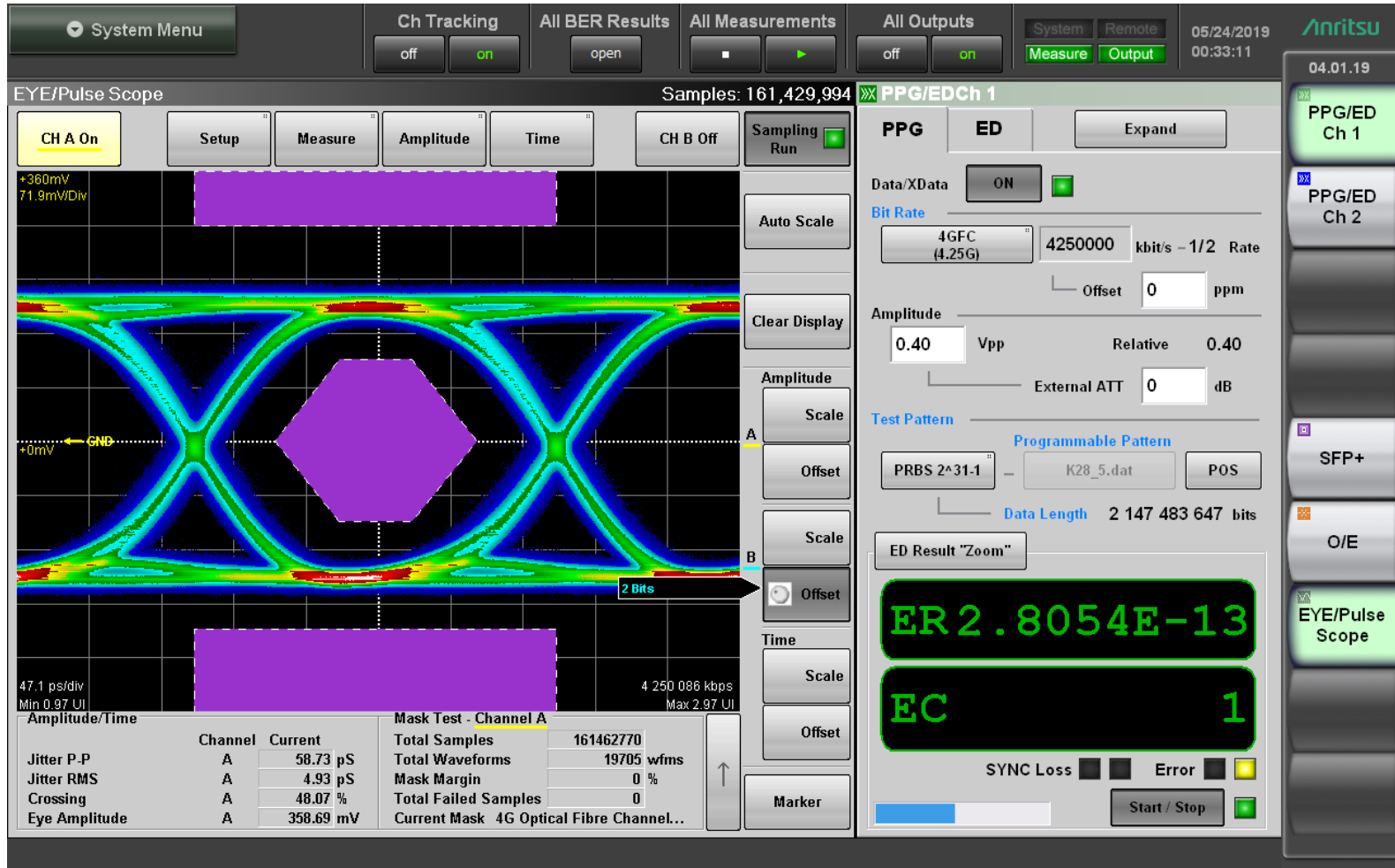

23°C

4.25Gbps with Optical Attenuation

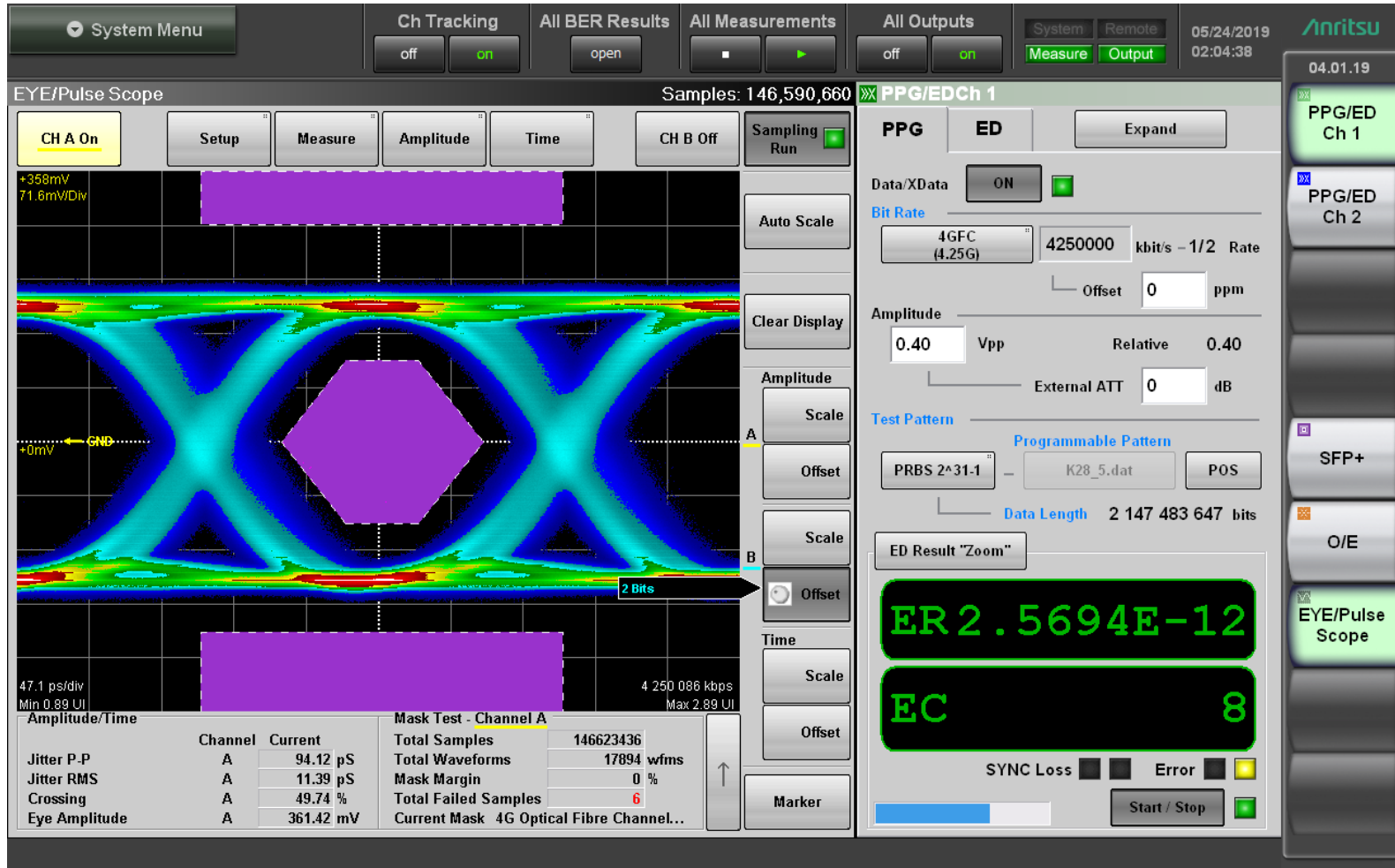

23°C

6Gbps No Attenuation

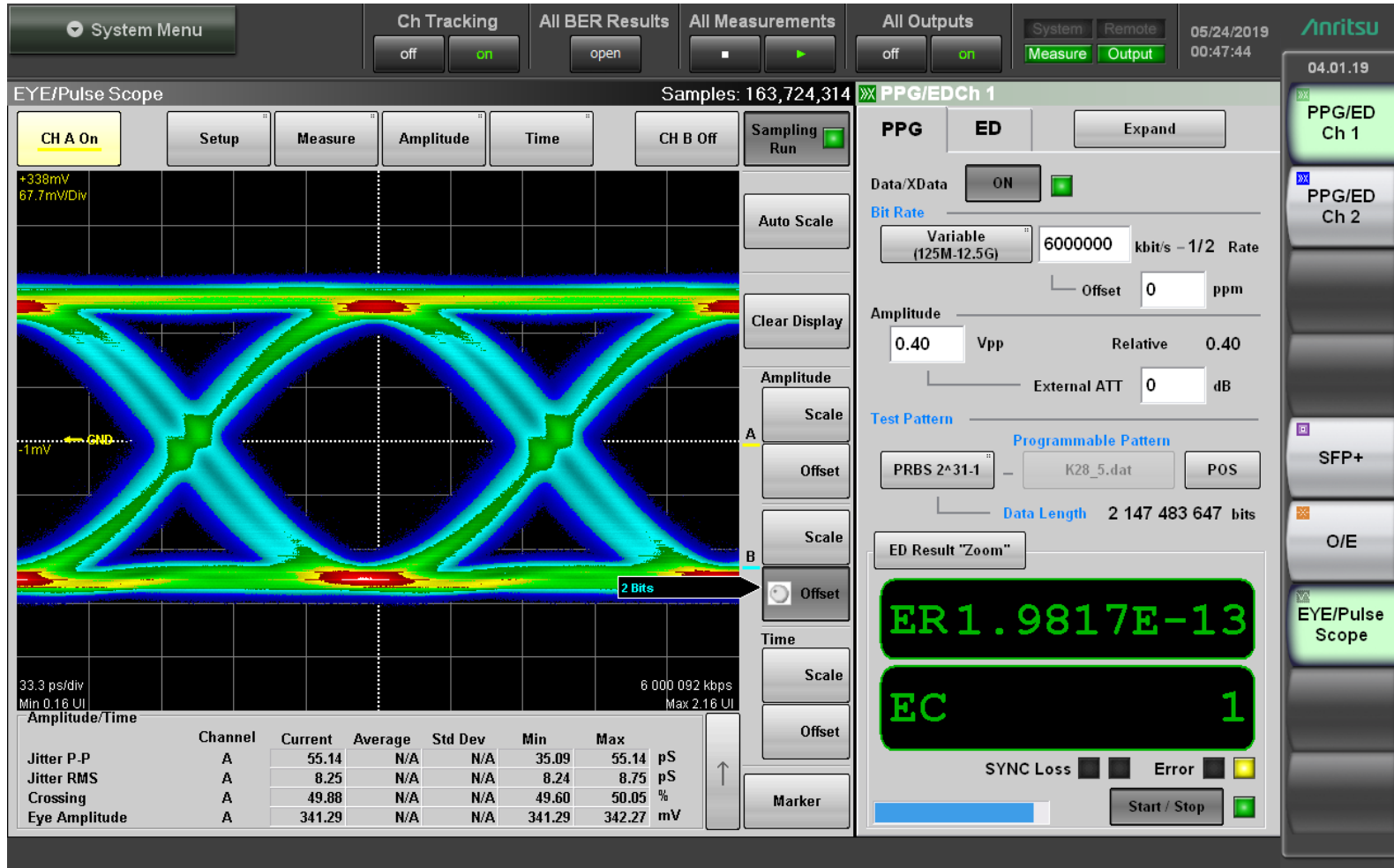

23°C

6Gbps with Optical Attenuation

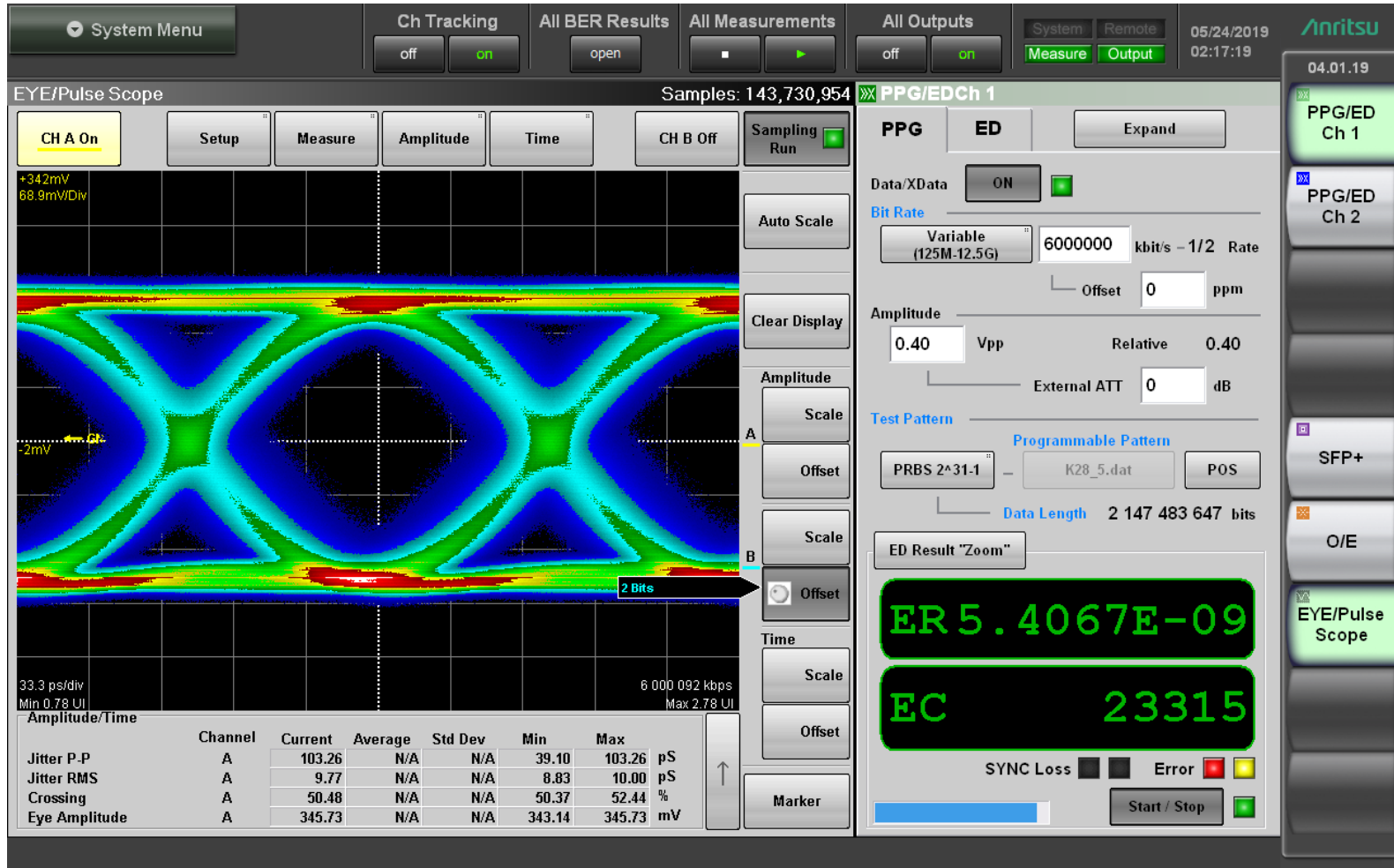

23°C

8.5Gbps No Attenuation

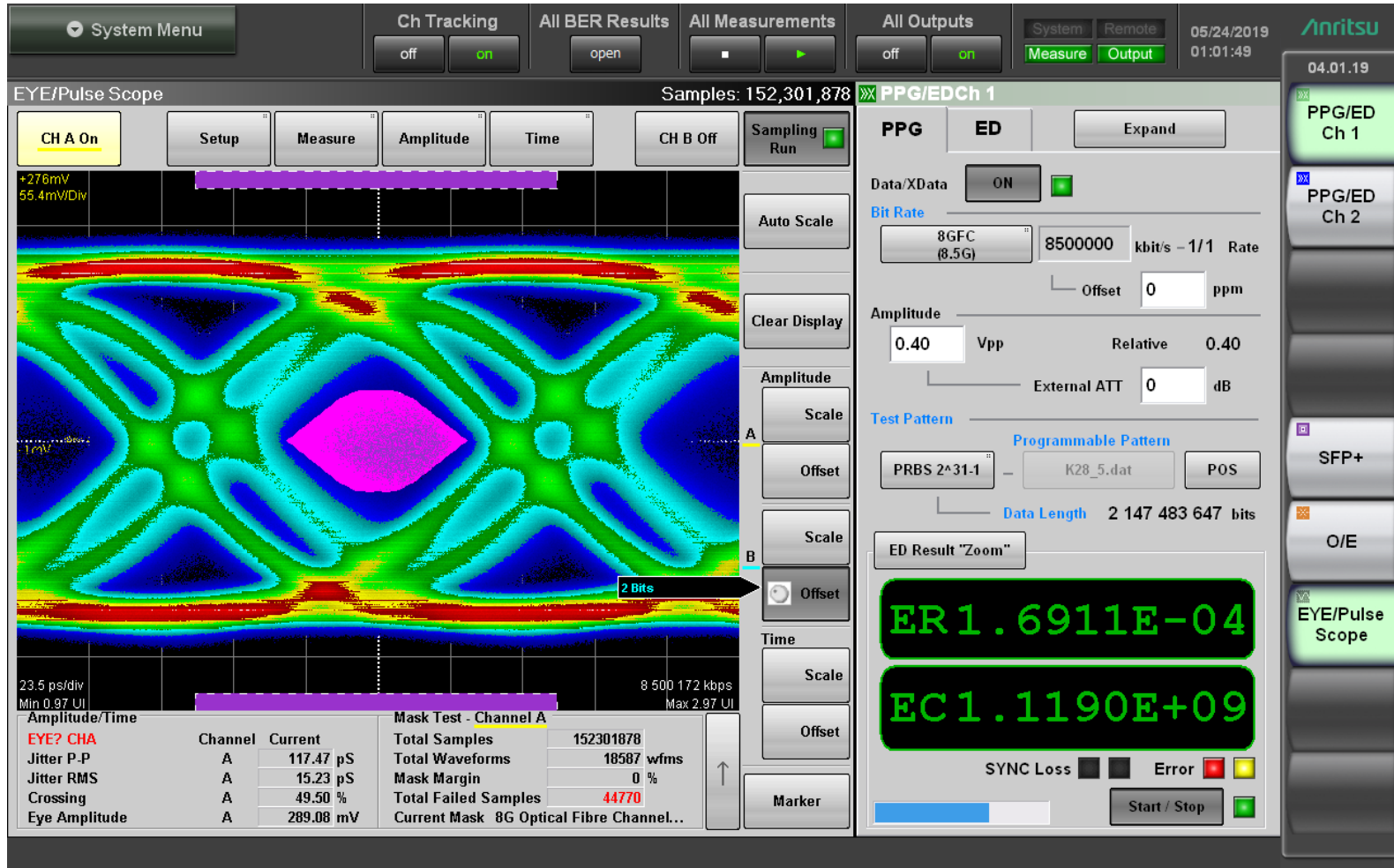

23°C

8.5Gbps with Optical Attenuation

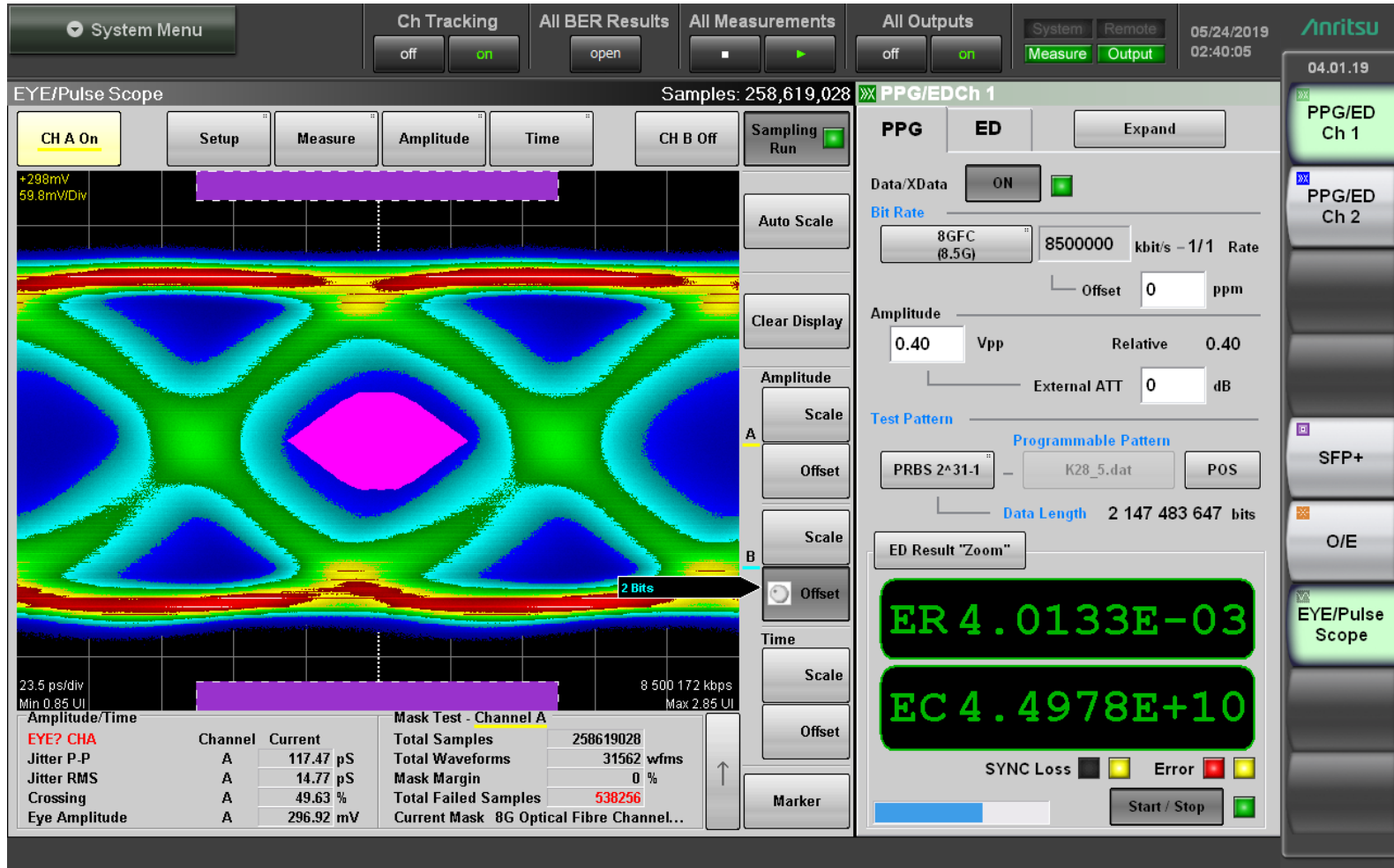

23°C

Bit Error Rate Summary (23°C)

Data Rate	Attenuation	BER (1 error injected manually)
125 Mbps	No	01.16E-08
125 Mbps	Yes	01.42E-10
500 Mbps	No	02.78E-12
500 Mbps	Yes	02.44E-12
1.25 Gbps	No	08.72E-13
1.25 Gbps	Yes	10.00E-13
4.25 Gbps	No	02.10E-13
4.25 Gbps	Yes	02.57E-12
6.00 Gbps	No	01.98E-13
6.00 Gbps	Yes	05.40E-09
8.50 Gbps	No	01.67E-04
8.50 Gbps	Yes	04.01E-03

CF-170300-034/035 Components are Rated from 155.00Mbps to 4.25Gbps but have Reasonable BER at up to 6Gbps

Temperature Performance Testing

- Tested at temperatures of 100, 85, -40, and -55 °C
- PRBS 2³¹-1 Pattern
- With and without optical attenuation using the following data rates:
 - 125 Mbps
 - 500 Mbps
 - 1.25 Gbps (using a GbE mask)
 - 4.25 Gbps (using a FibreChannel mask)
 - 6.00 Gbps
- The optical attenuator was set such that the receiver received -15dBm of optical power from the transmitter
- Duration of each test was roughly 10 minutes
- For every test performed one error was purposely injected in order to have a BER

125 Mbps No Attenuation

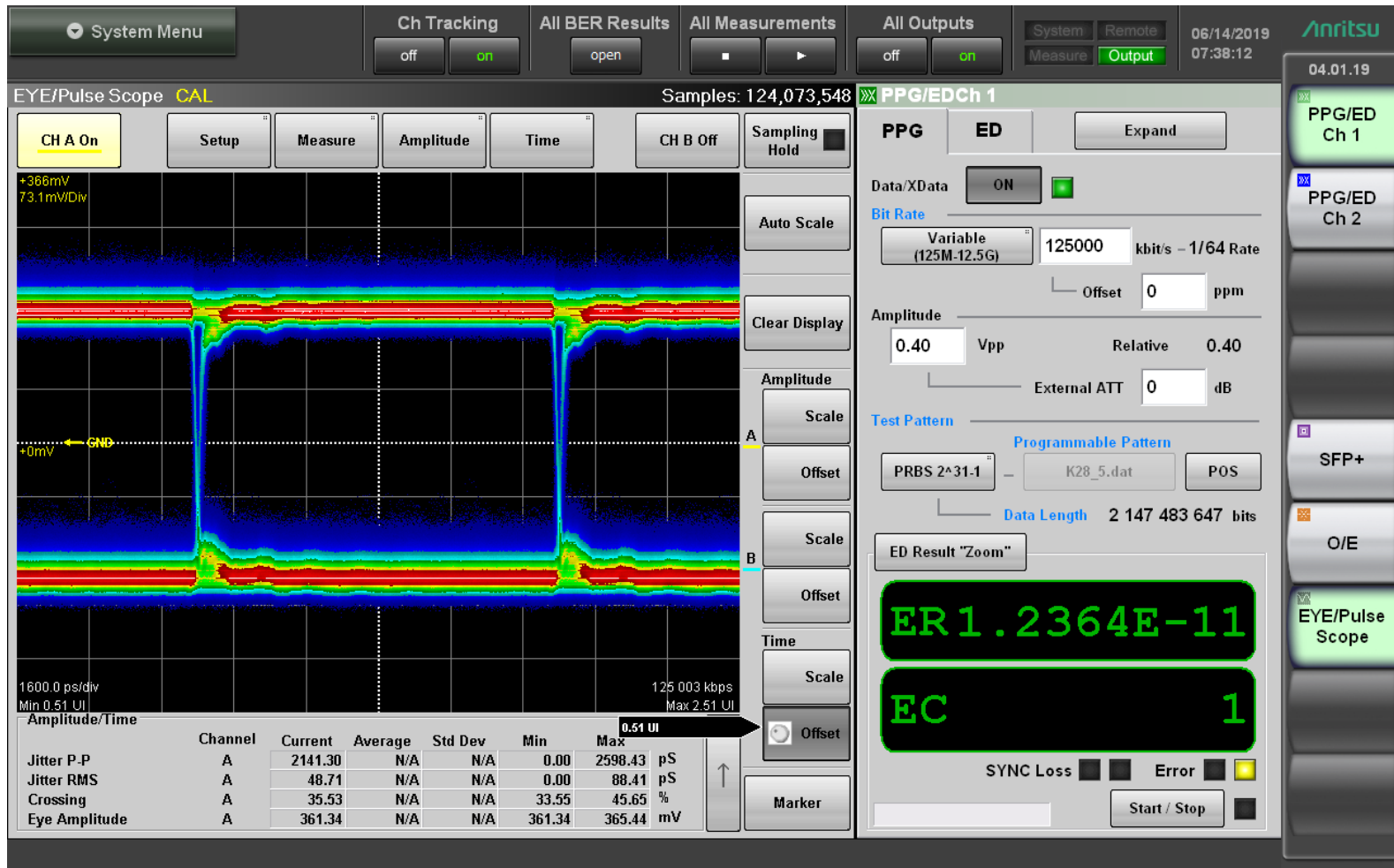

100°C

125 Mbps with Optical Attenuation

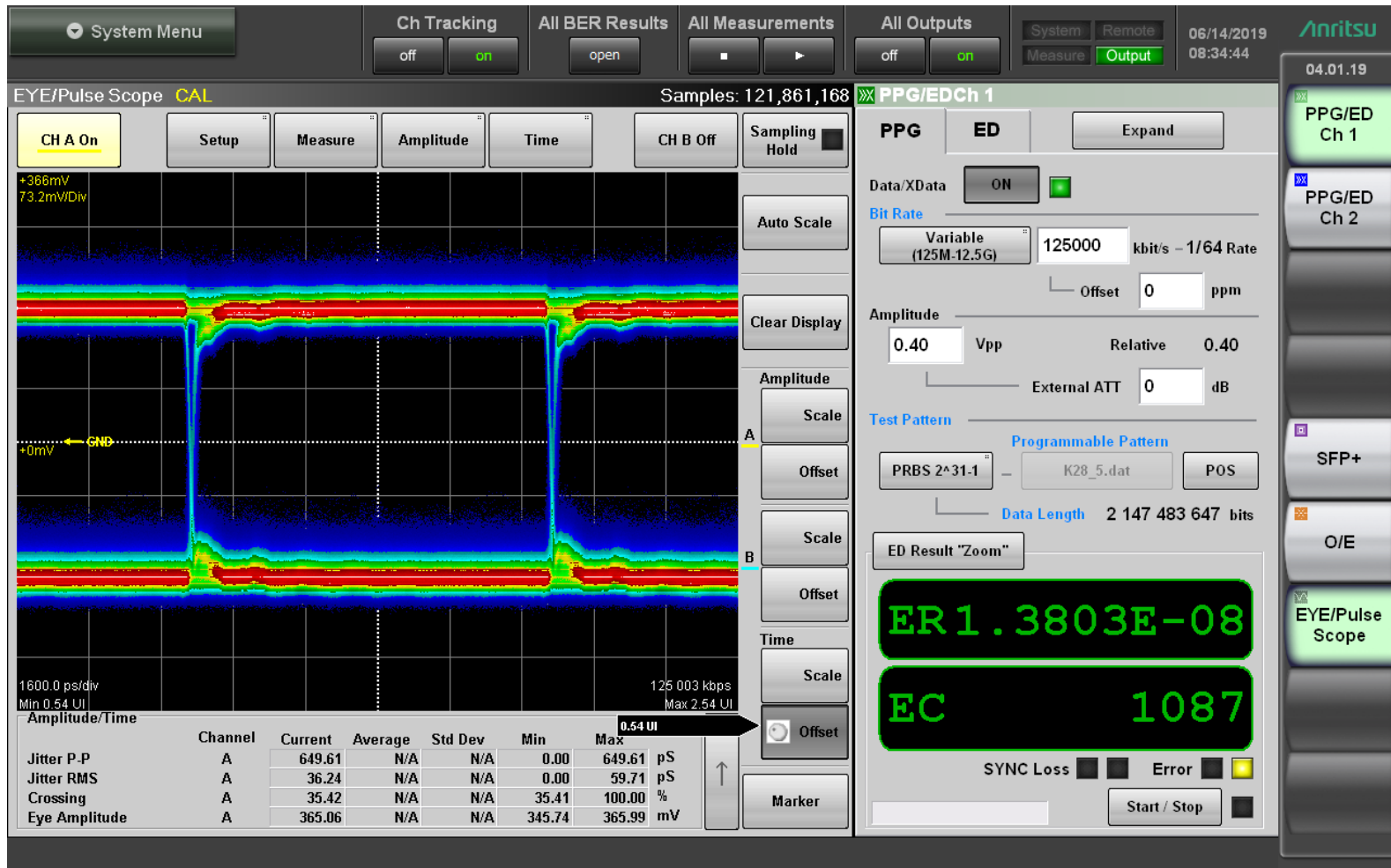

100°C

500 Mbps No Attenuation

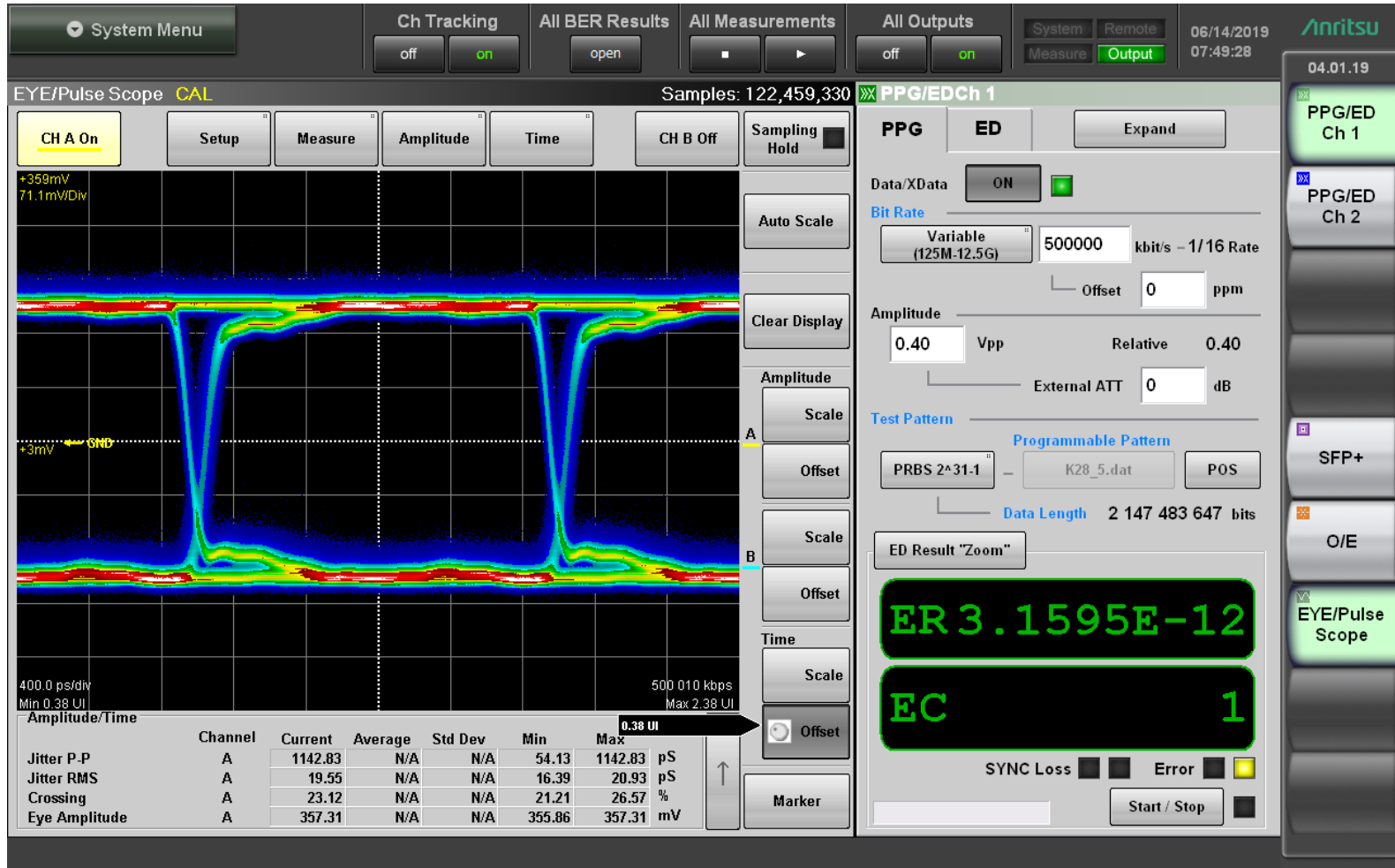

100°C

500 Mbps with Optical Attenuation

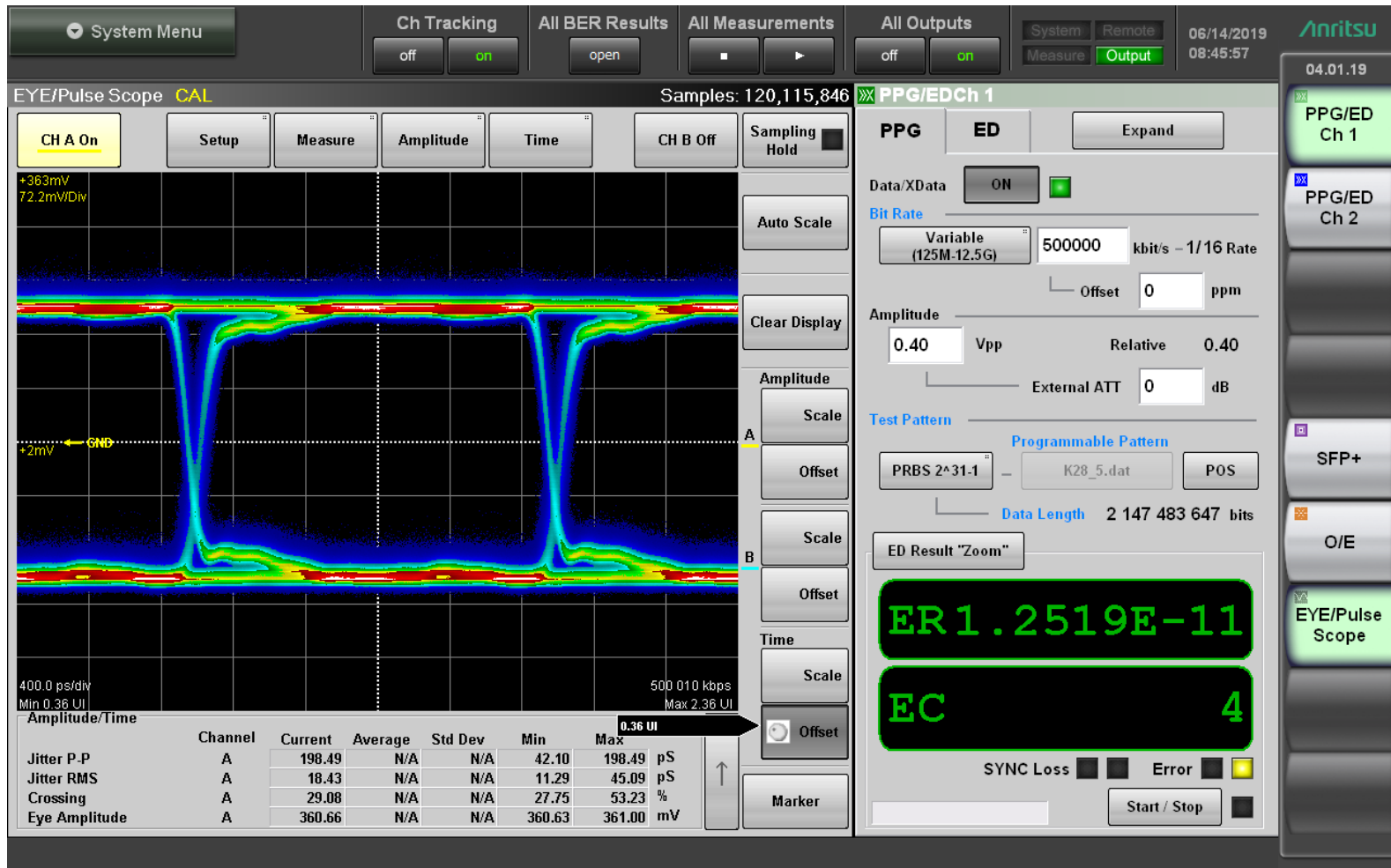

100°C

1.25 Gbps No Attenuation

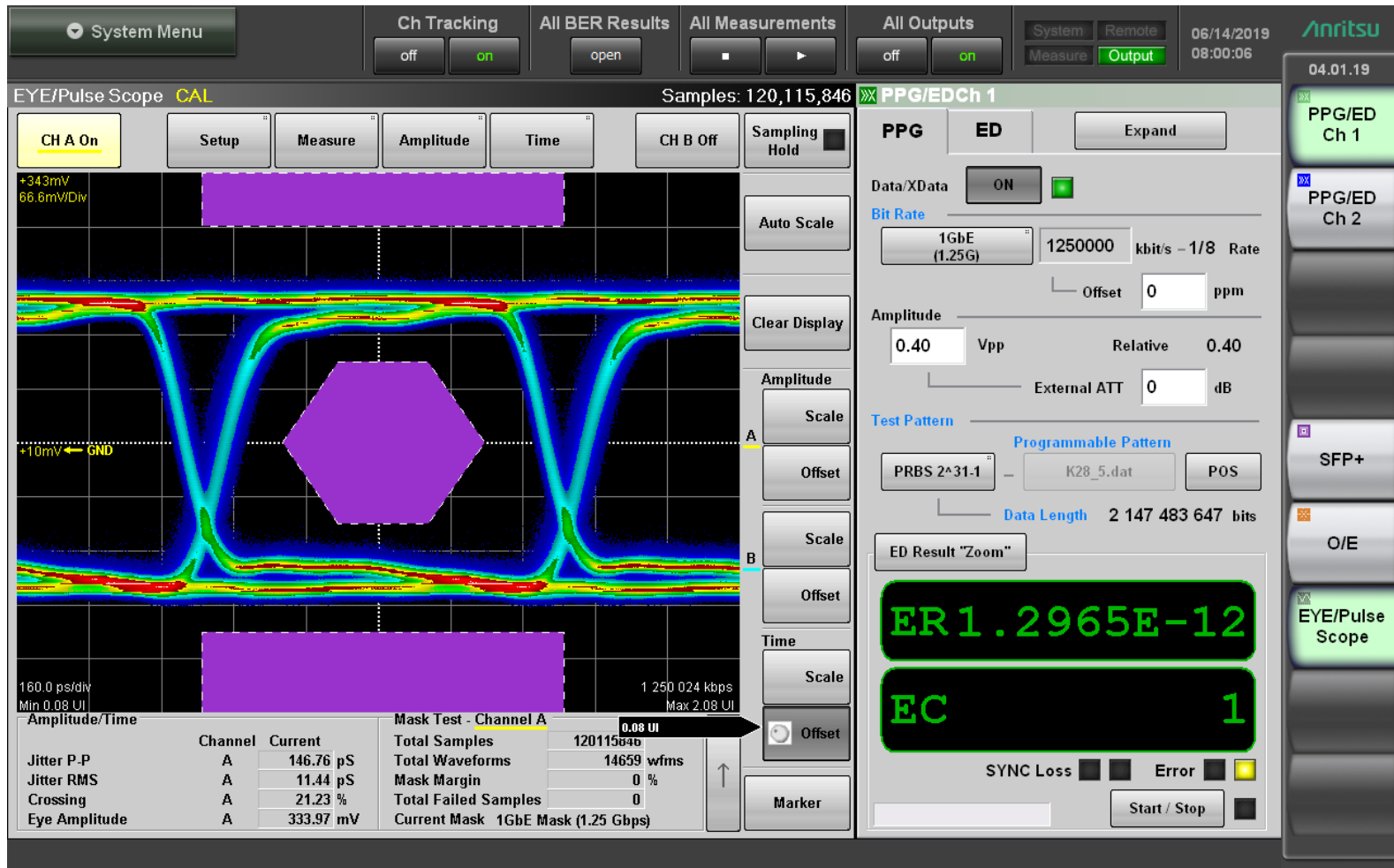

100°C

1.25 Gbps with Optical Attenuation

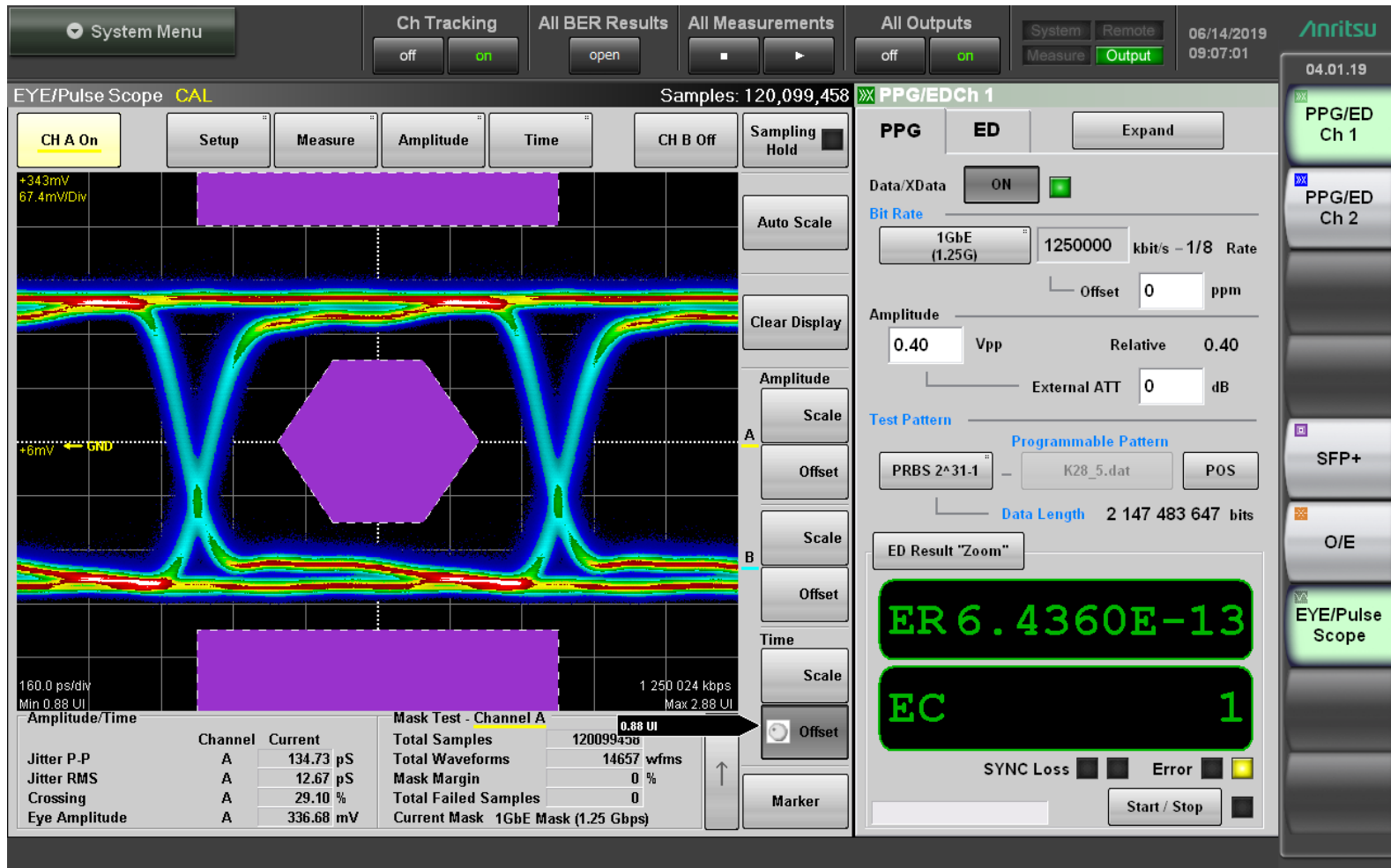

100°C

4.25 Gbps No Attenuation

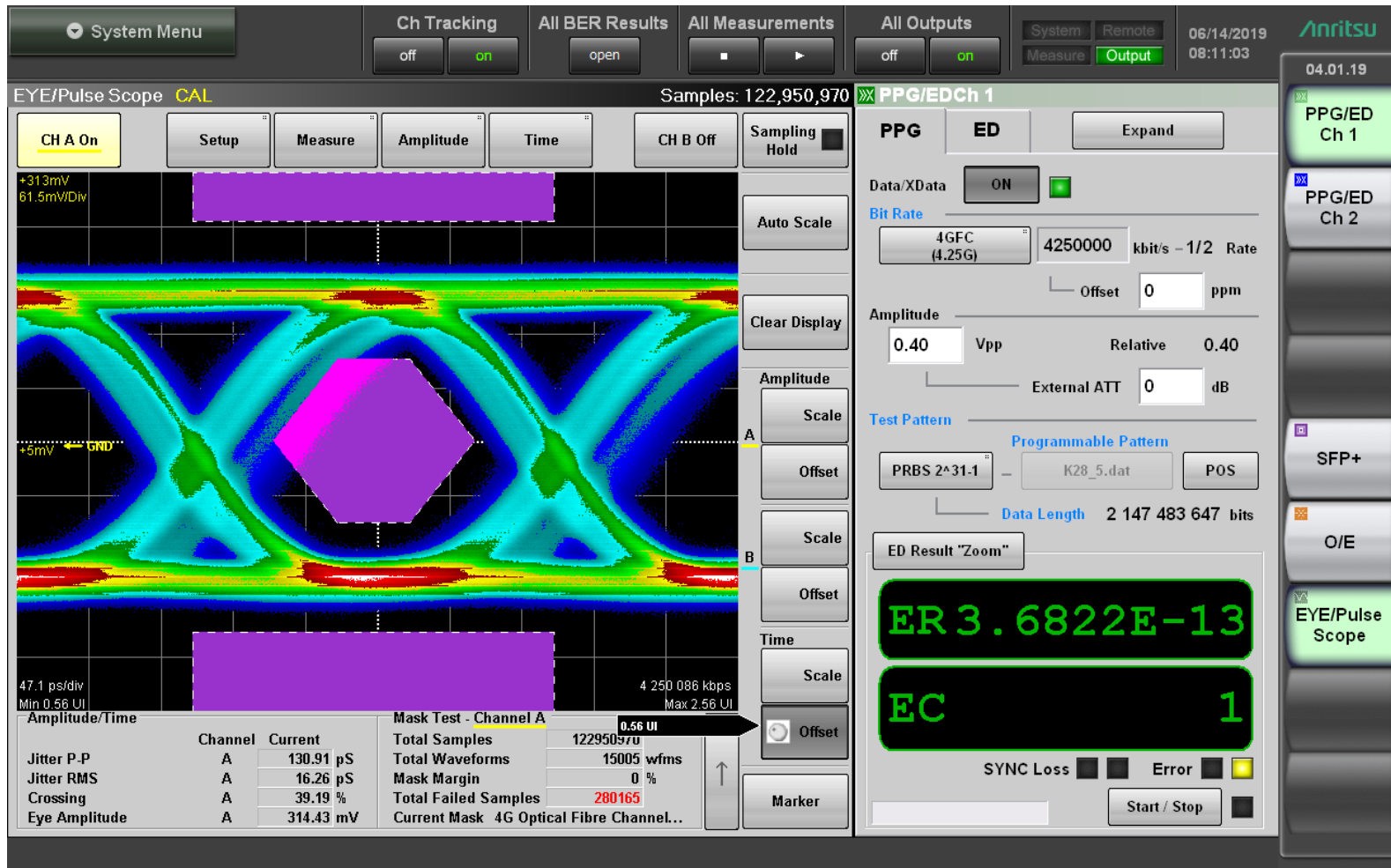

100°C

4.25 Gbps with Optical Attenuation

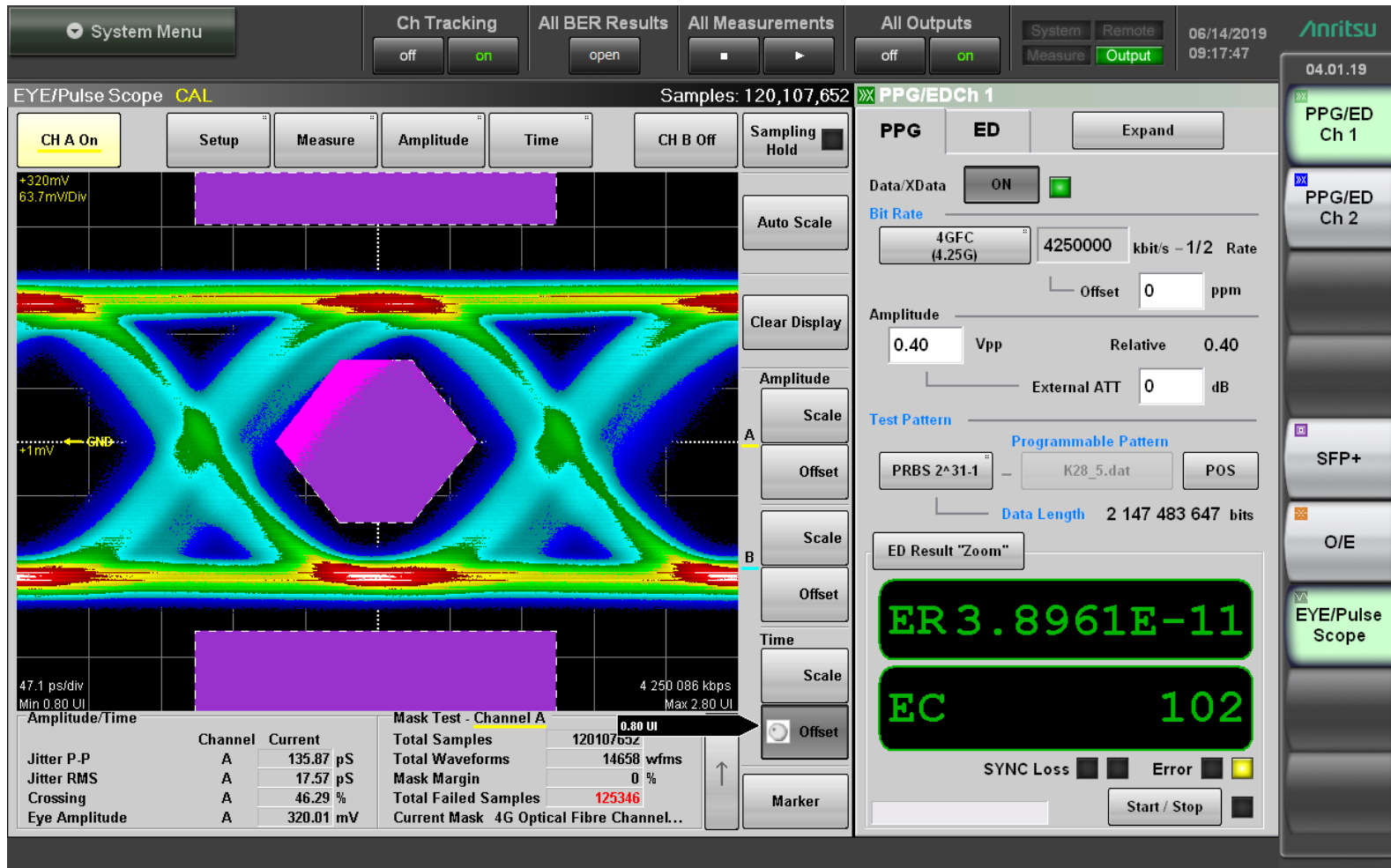

100°C

6 Gbps No Attenuation

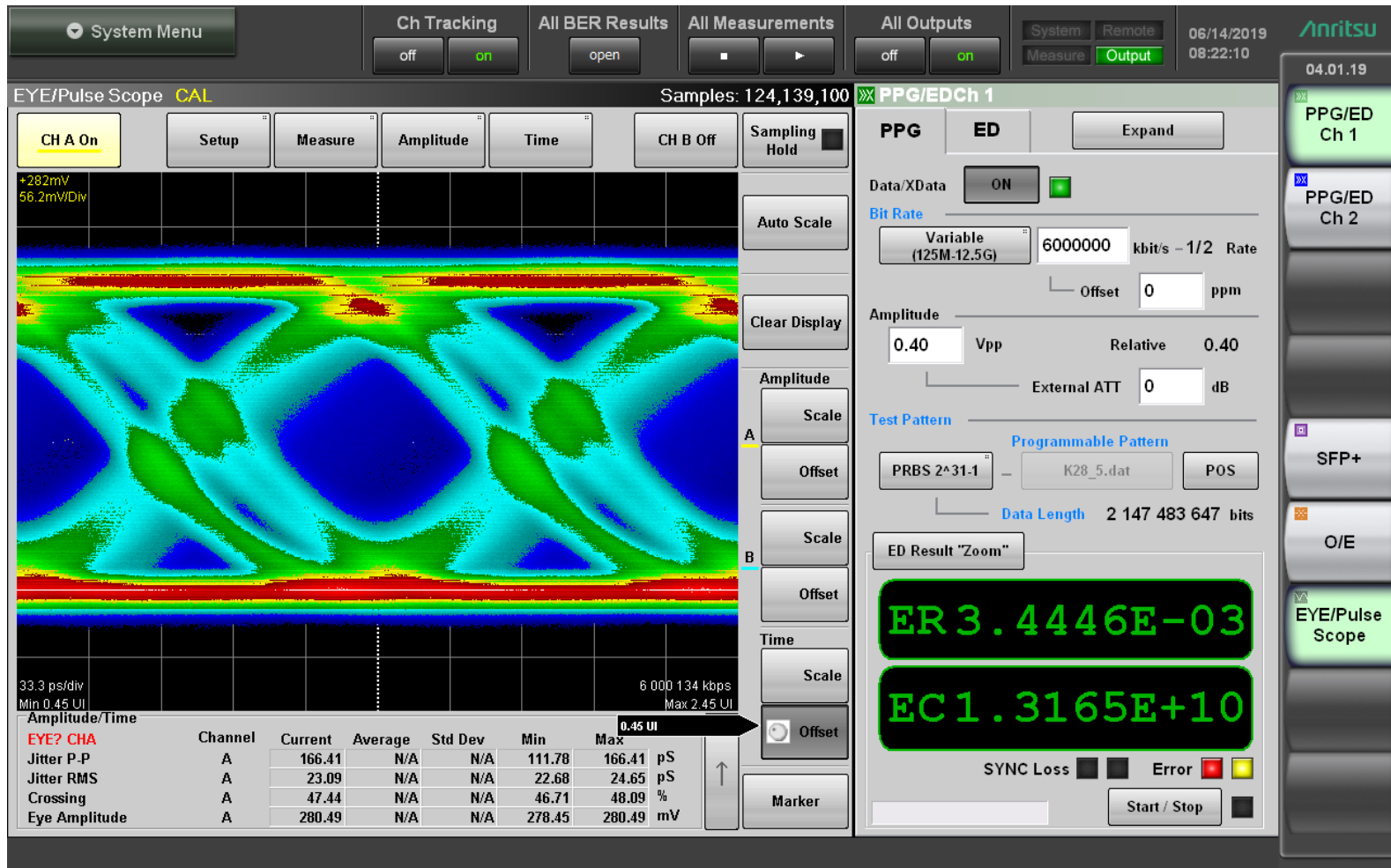

100°C

6 Gbps with Optical Attenuation

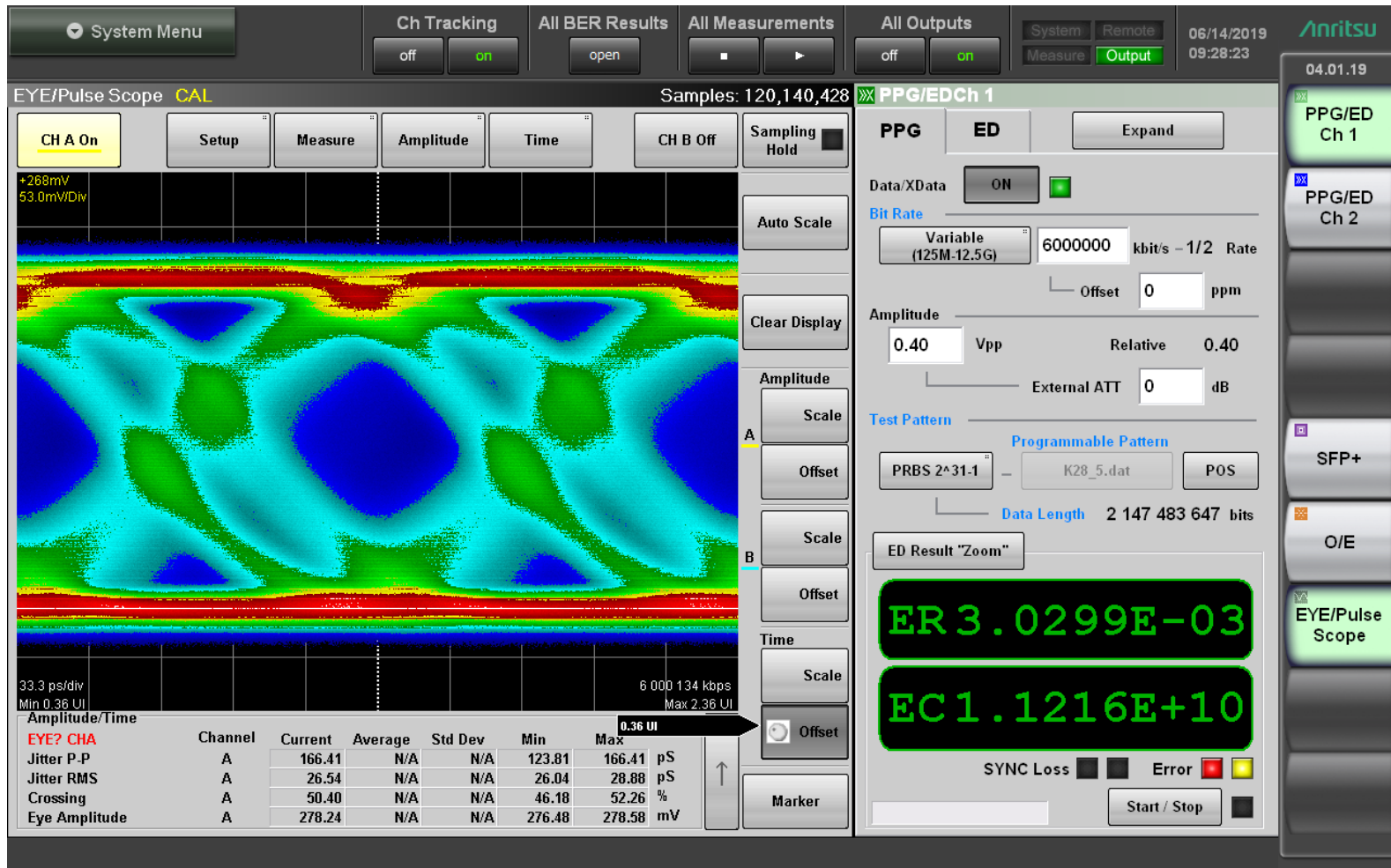

100°C

Bit Error Rate Summary (100°C)

Data Rate	Attenuation	BER (1 error injected manually)
125 Mbps	No	1.23E-11
125 Mbps	Yes	1.38E-08
500 Mbps	No	3.16E-12
500 Mbps	Yes	1.25E-11
1.25 Gbps	No	1.30E-12
1.25 Gbps	Yes	6.44E-13
4.25 Gbps	No	3.68E-13
4.25 Gbps	Yes	3.90E-11
6.00 Gbps	No	3.44E-03
6.00 Gbps	Yes	3.03E-03

CF-170300-034/035 Components are Rated from 155.00Mbps to 4.25Gbps but have Reasonable BER at up to 6Gbps

125 Mbps No Attenuation

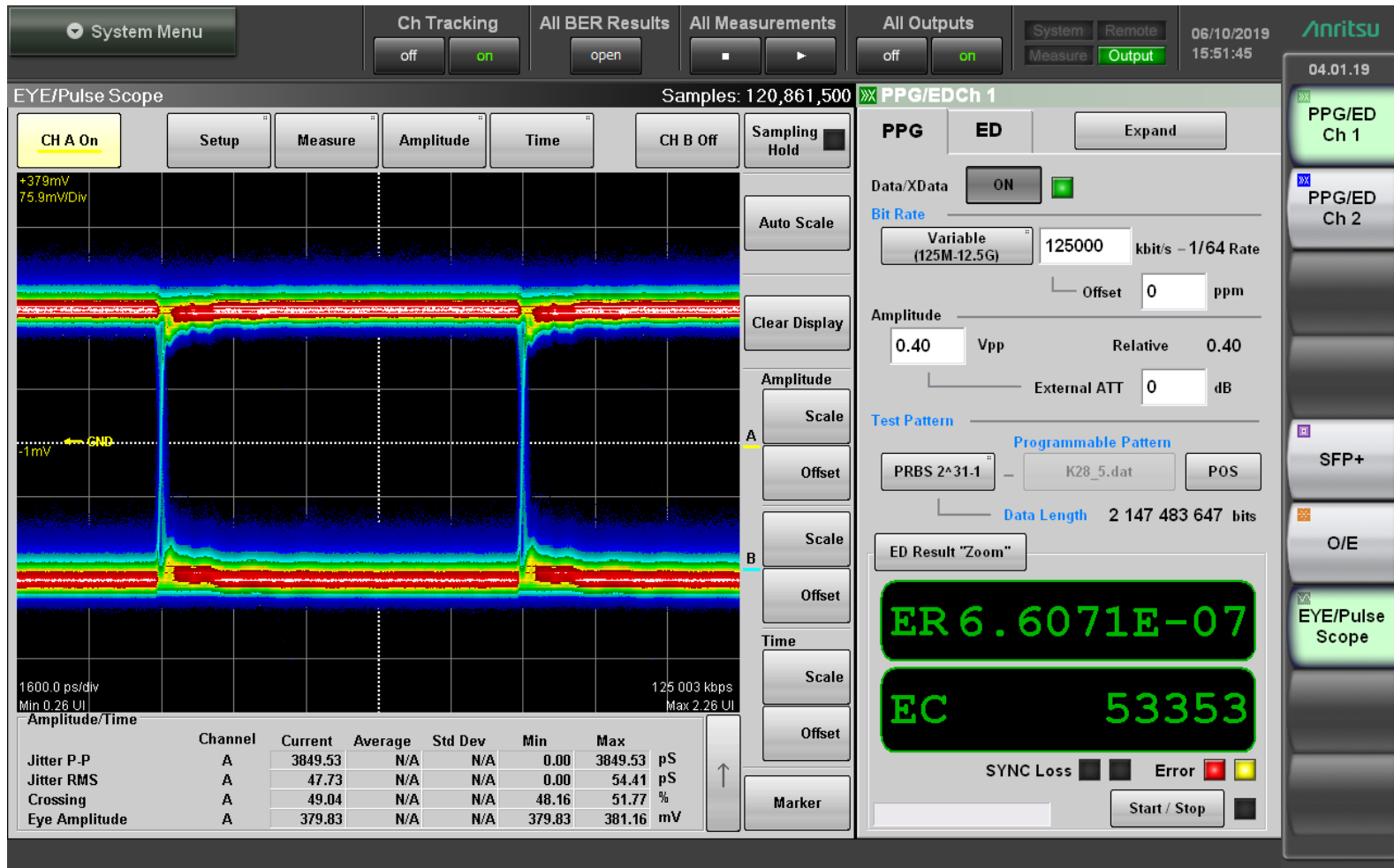

85°C

125 Mbps with Optical Attenuation

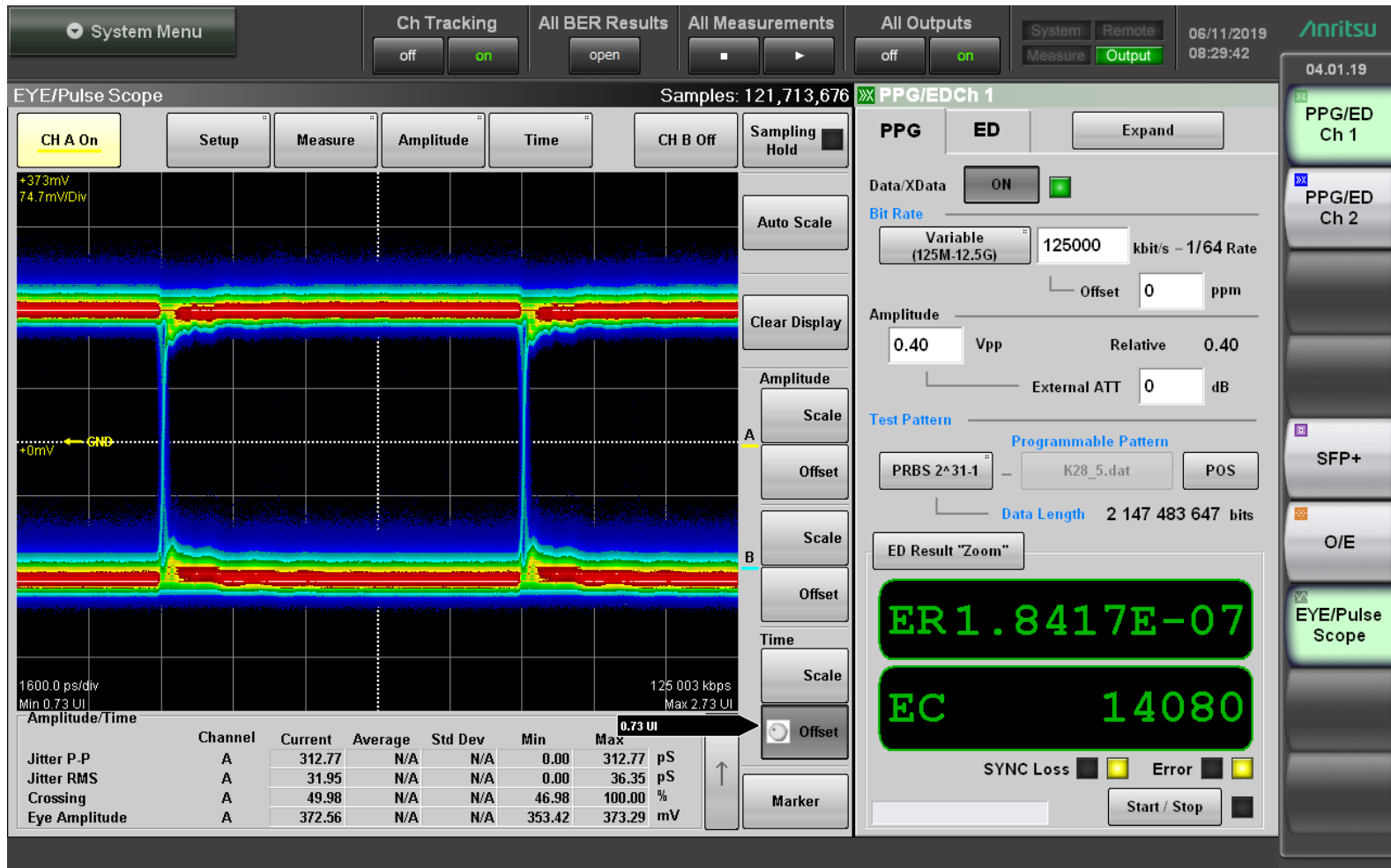

85°C

500 Mbps No Attenuation

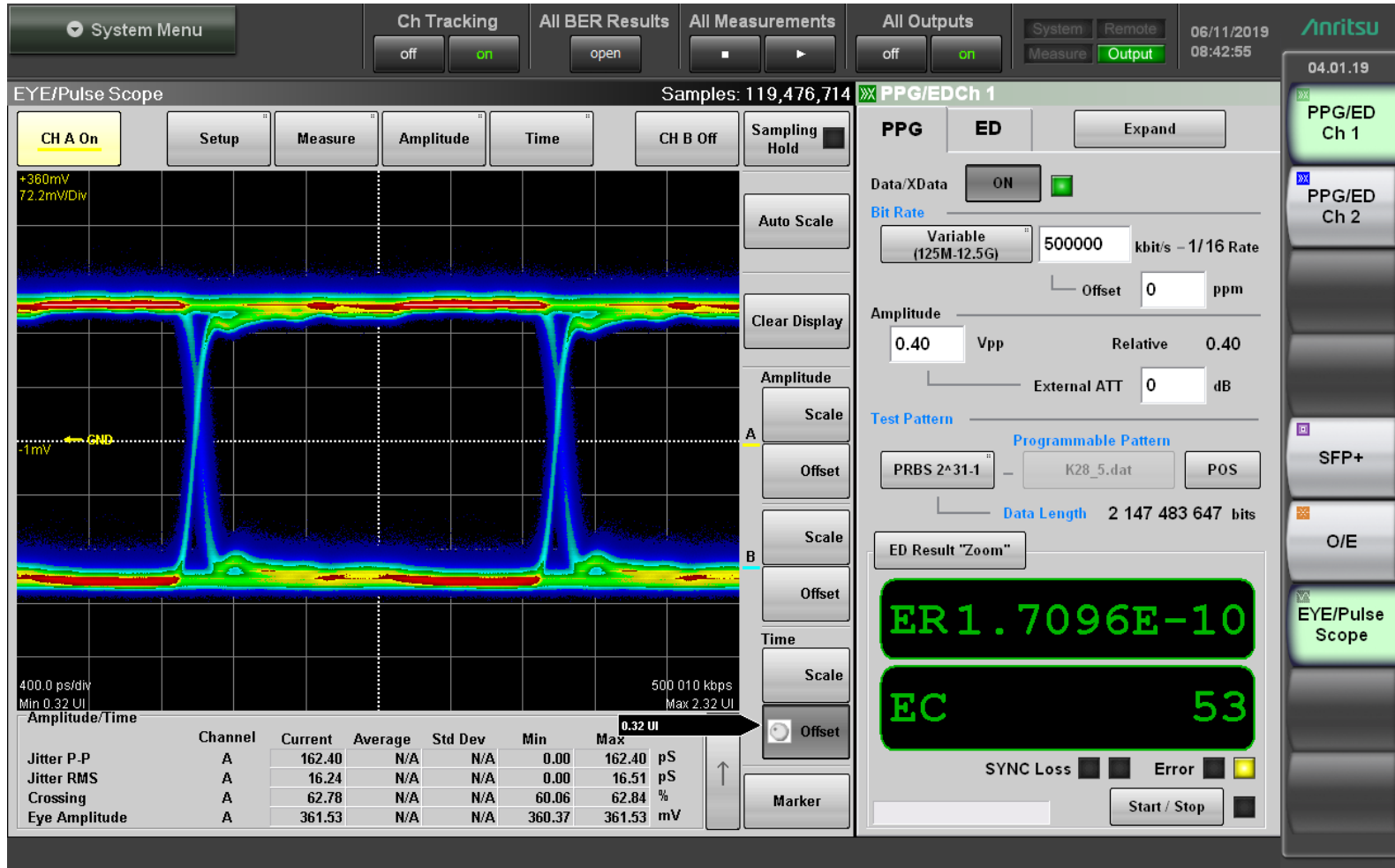

85°C

500 Mbps with Optical Attenuation

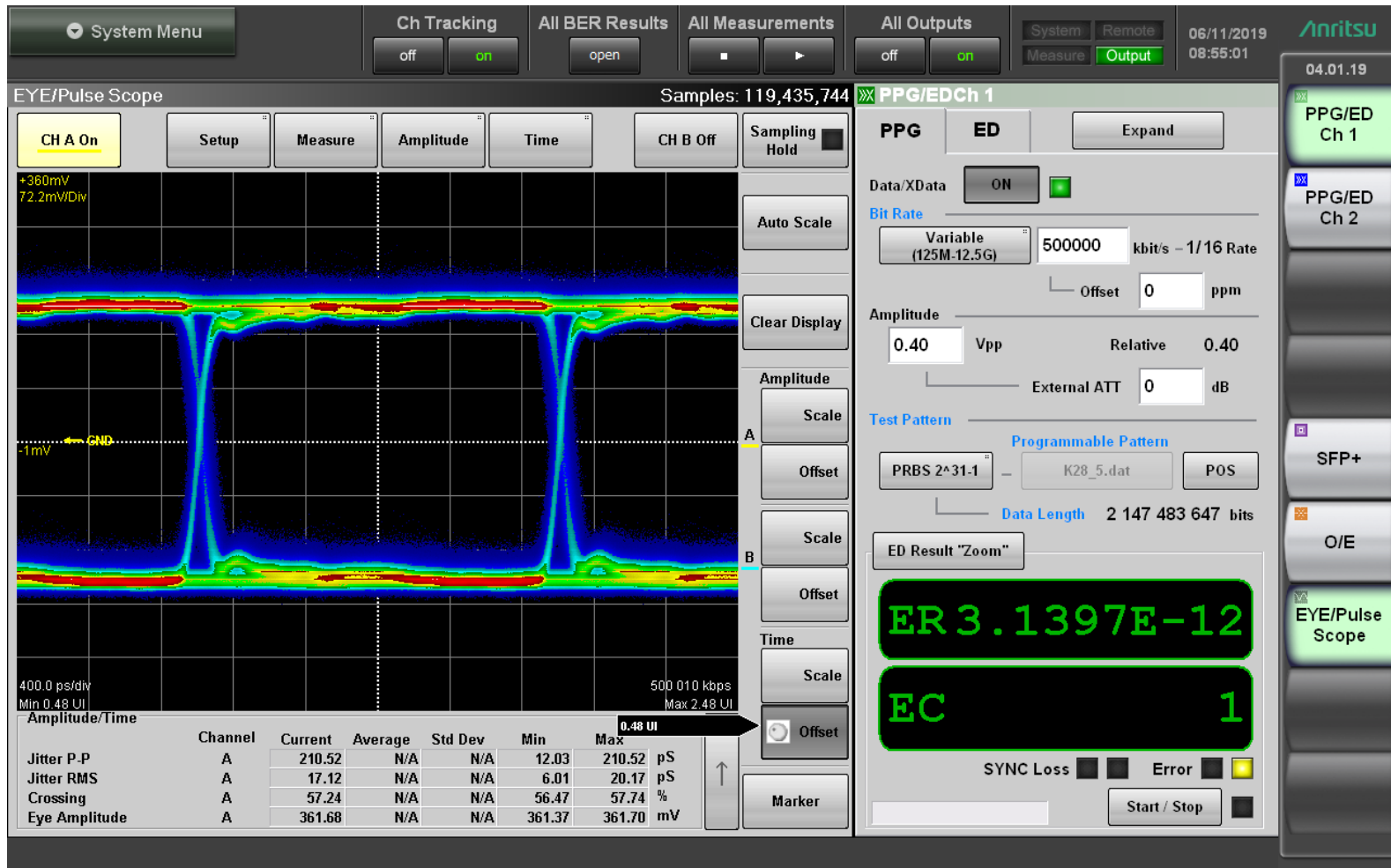

85°C

1.25 Gbps No Attenuation

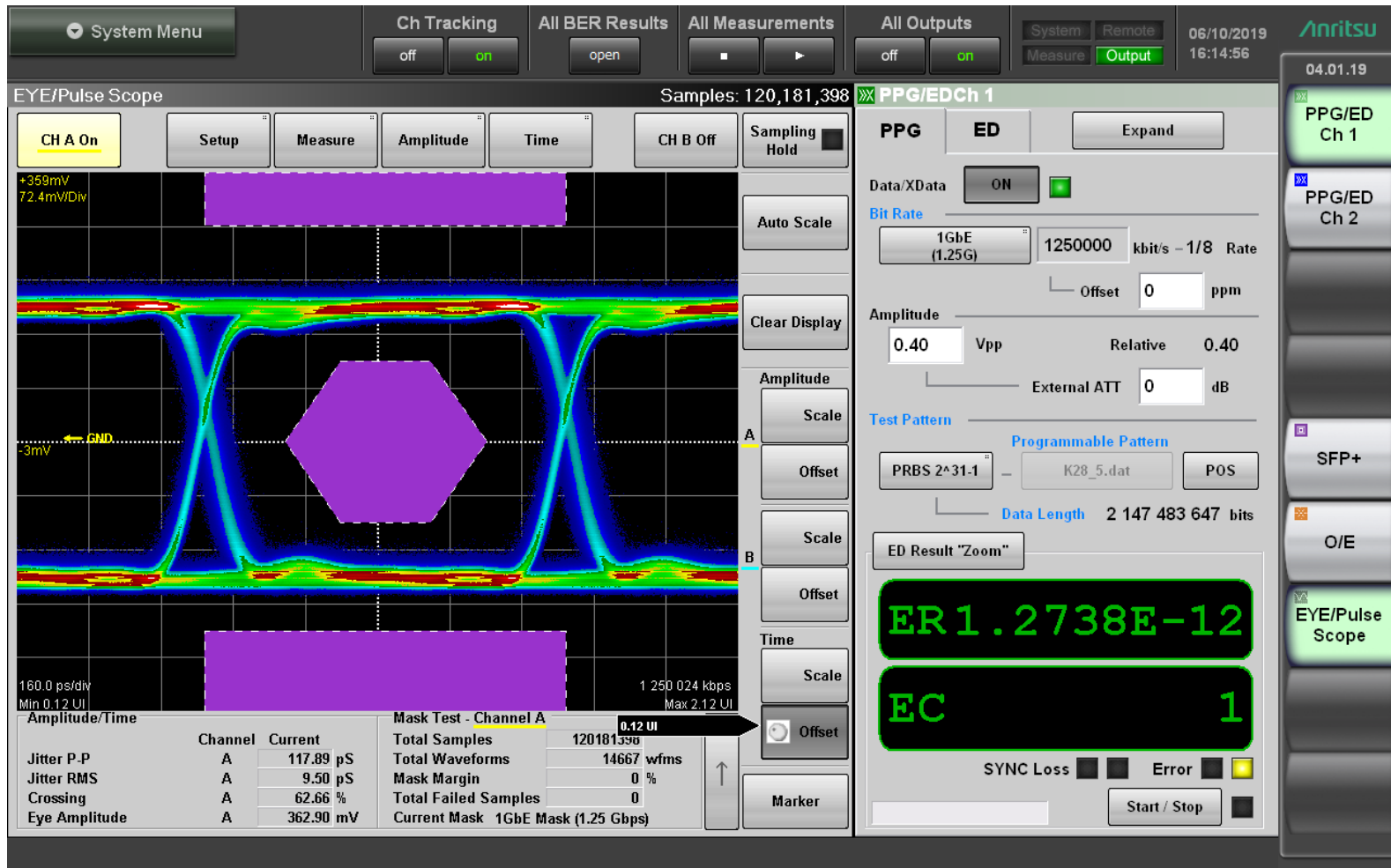

85°C

1.25 Gbps with Optical Attenuation

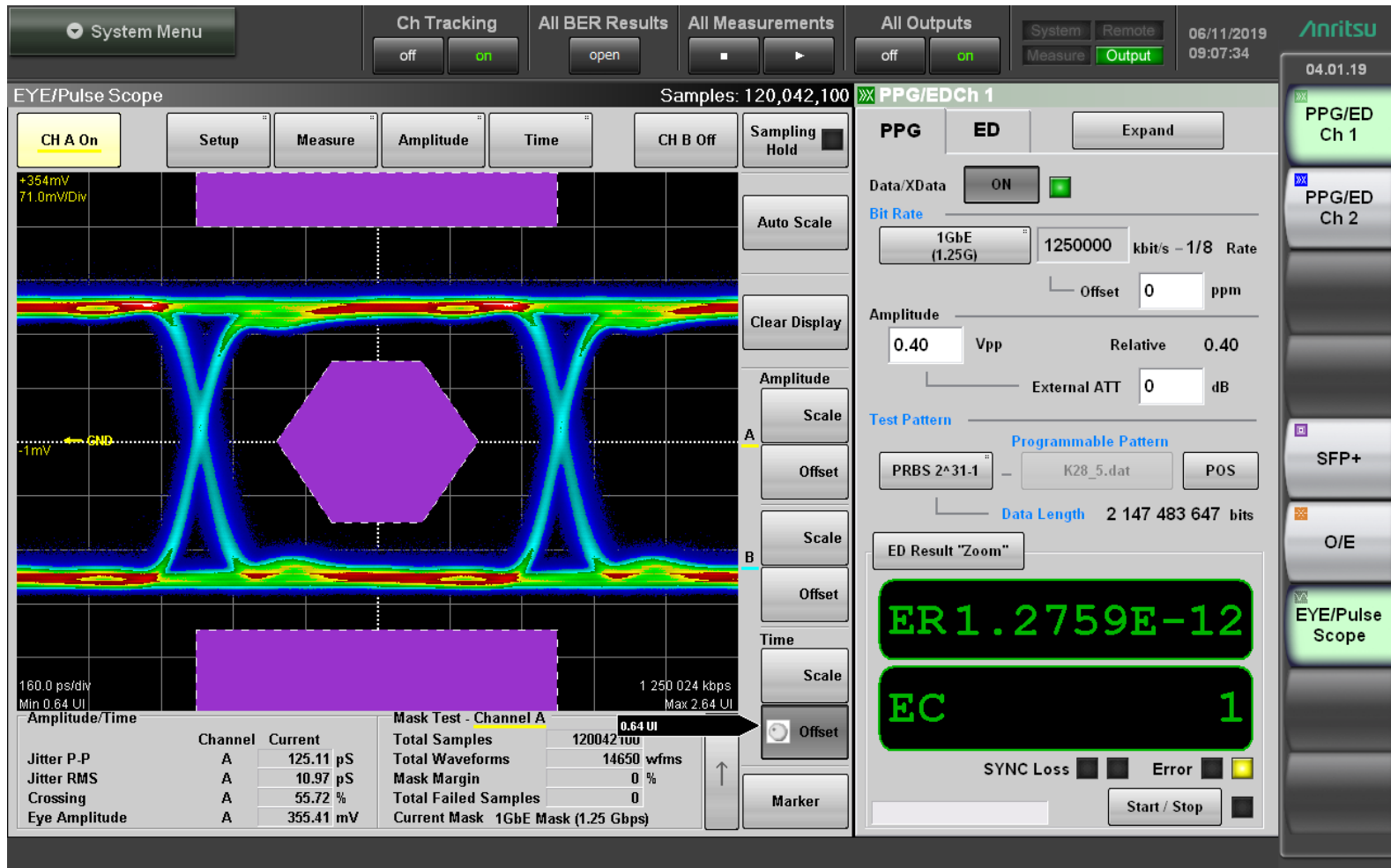

85°C

4.25 Gbps No Attenuation

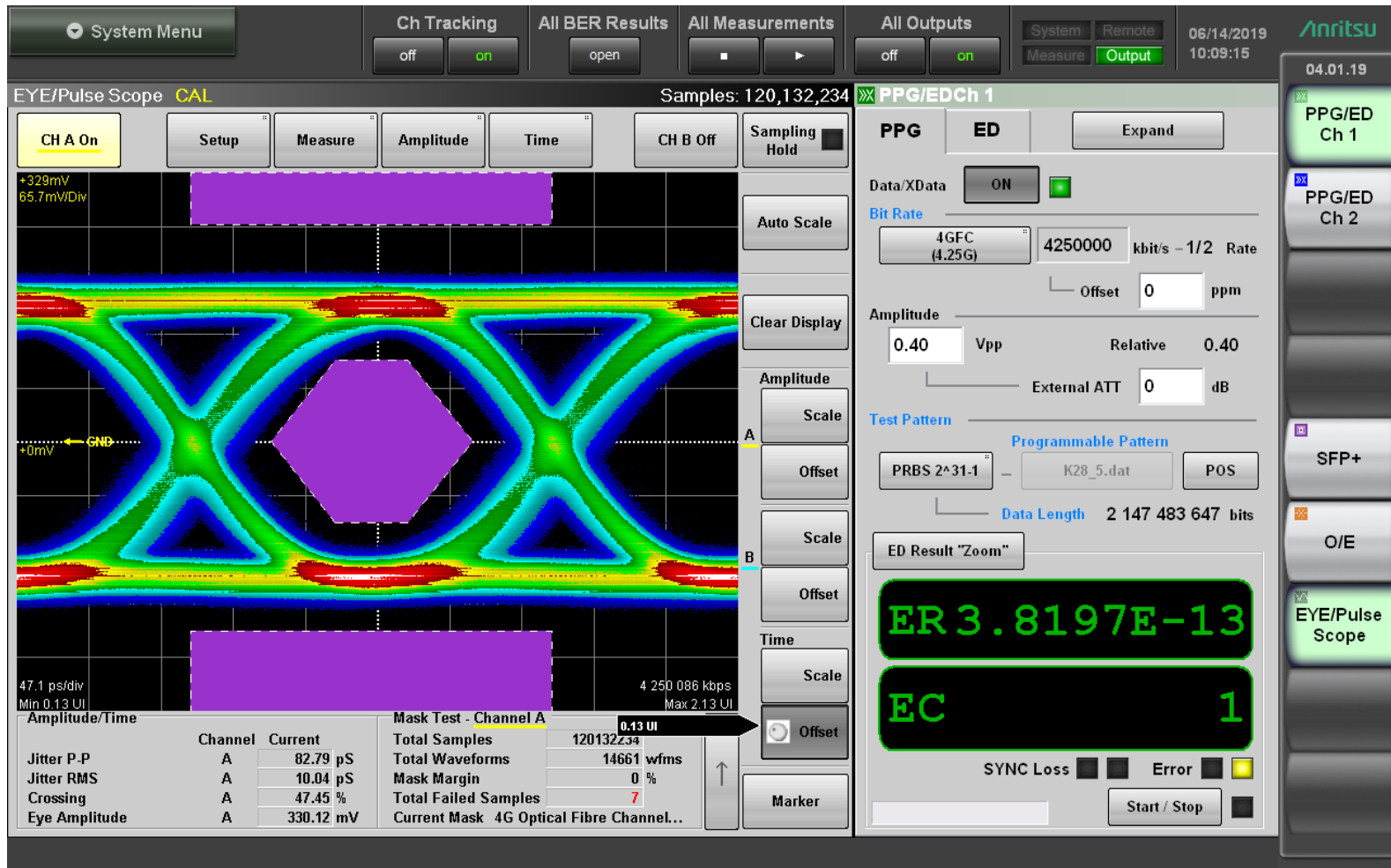

85°C

4.25 Gbps with Optical Attenuation

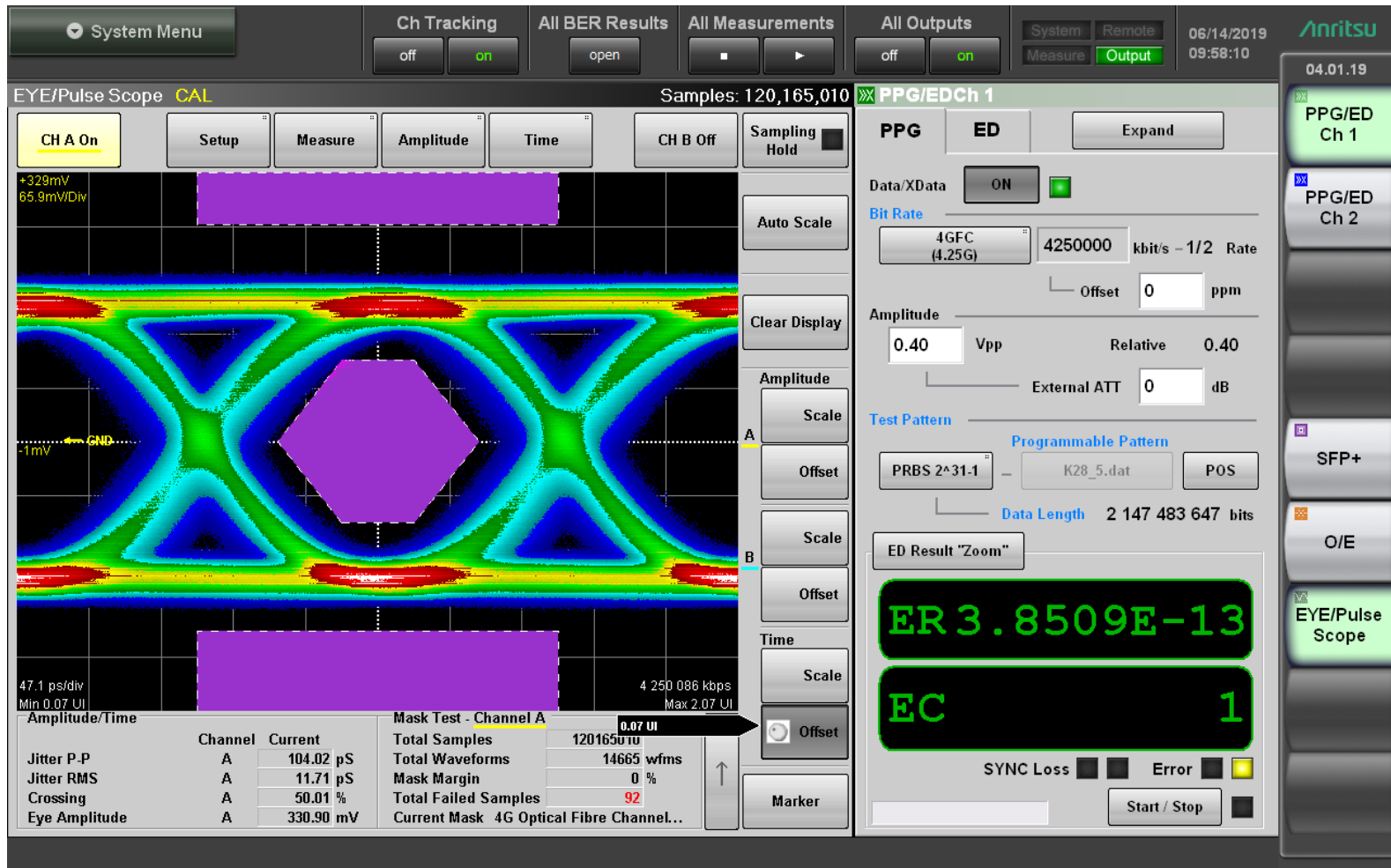

85°C

6 Gbps No Attenuation

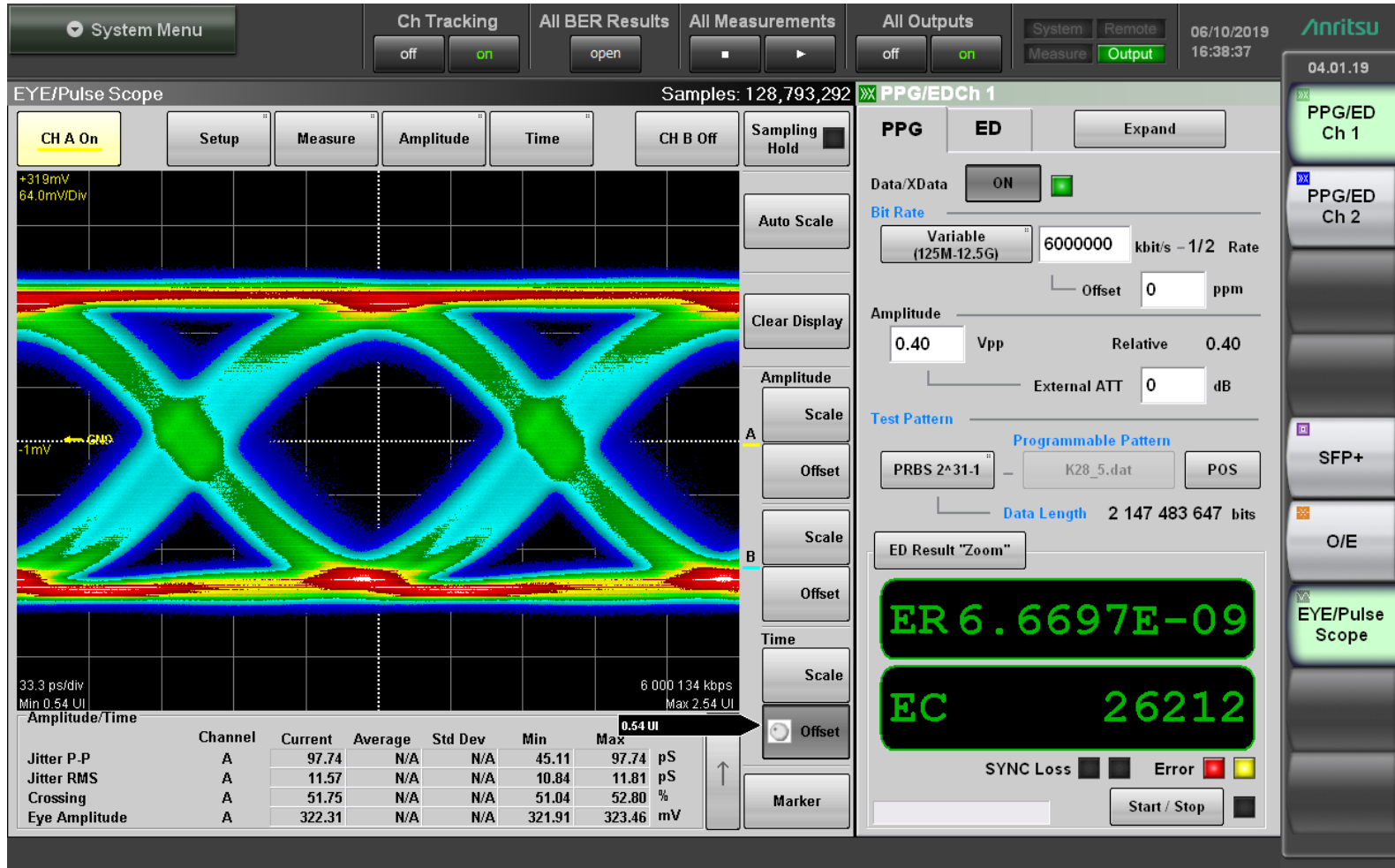

85°C

6 Gbps with Optical Attenuation

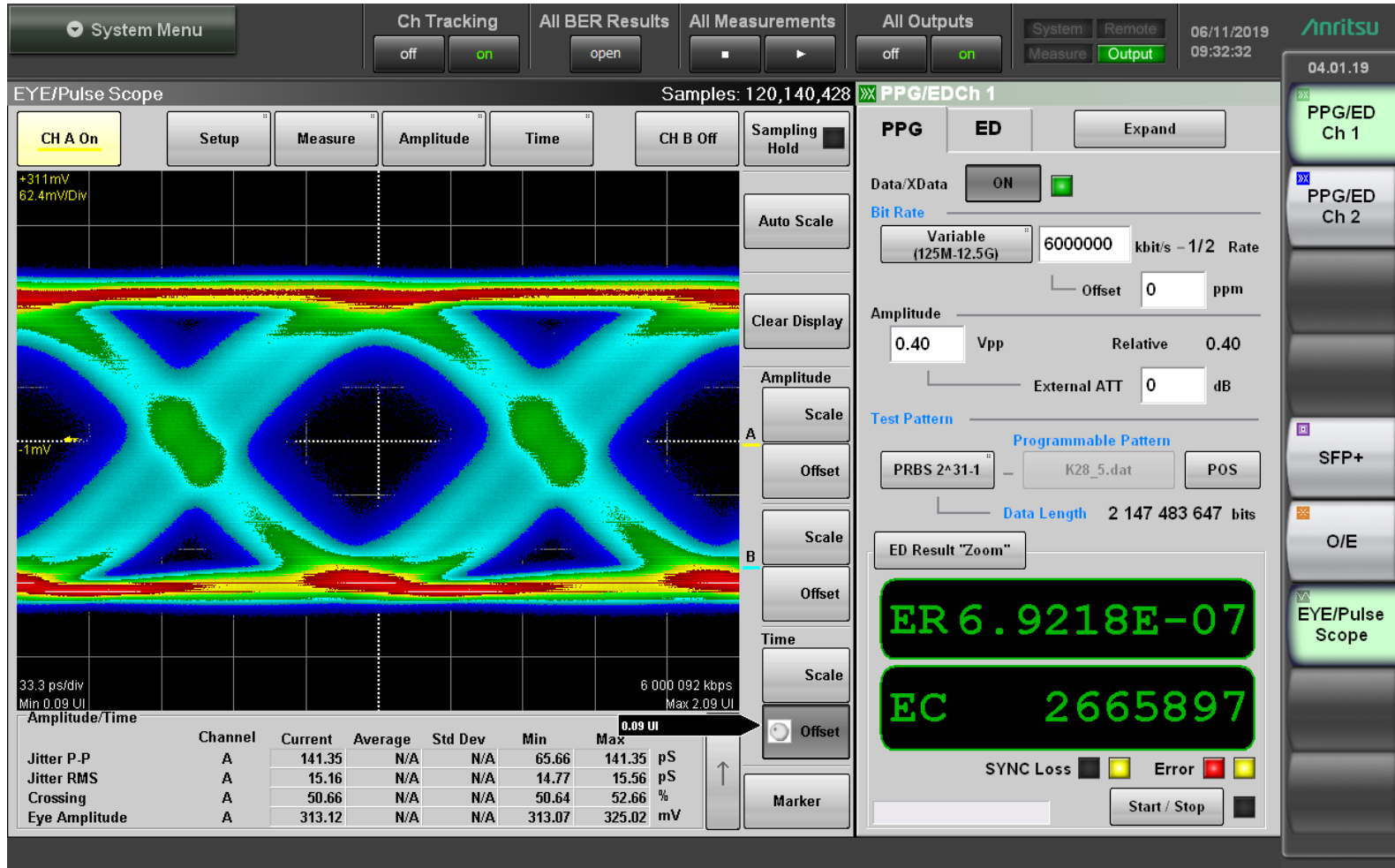

85°C

Bit Error Rate Summary (85°C)

Data Rate	Attenuation	BER (1 error injected manually)
125 Mbps	No	6.61E-07
125 Mbps	Yes	1.84E-07
500 Mbps	No	1.71E-10
500 Mbps	Yes	3.14E-12
1.25 Gbps	No	1.27E-12
1.25 Gbps	Yes	1.28E-12
4.25 Gbps	No	3.82E-13
4.25 Gbps	Yes	3.85E-13
6.00 Gbps	No	6.67E-07
6.00 Gbps	Yes	6.92E-09

CF-170300-034/035 Components are Rated from 155.00Mbps to 4.25Gbps but have Reasonable BER at up to 6Gbps

125 Mbps No Attenuation

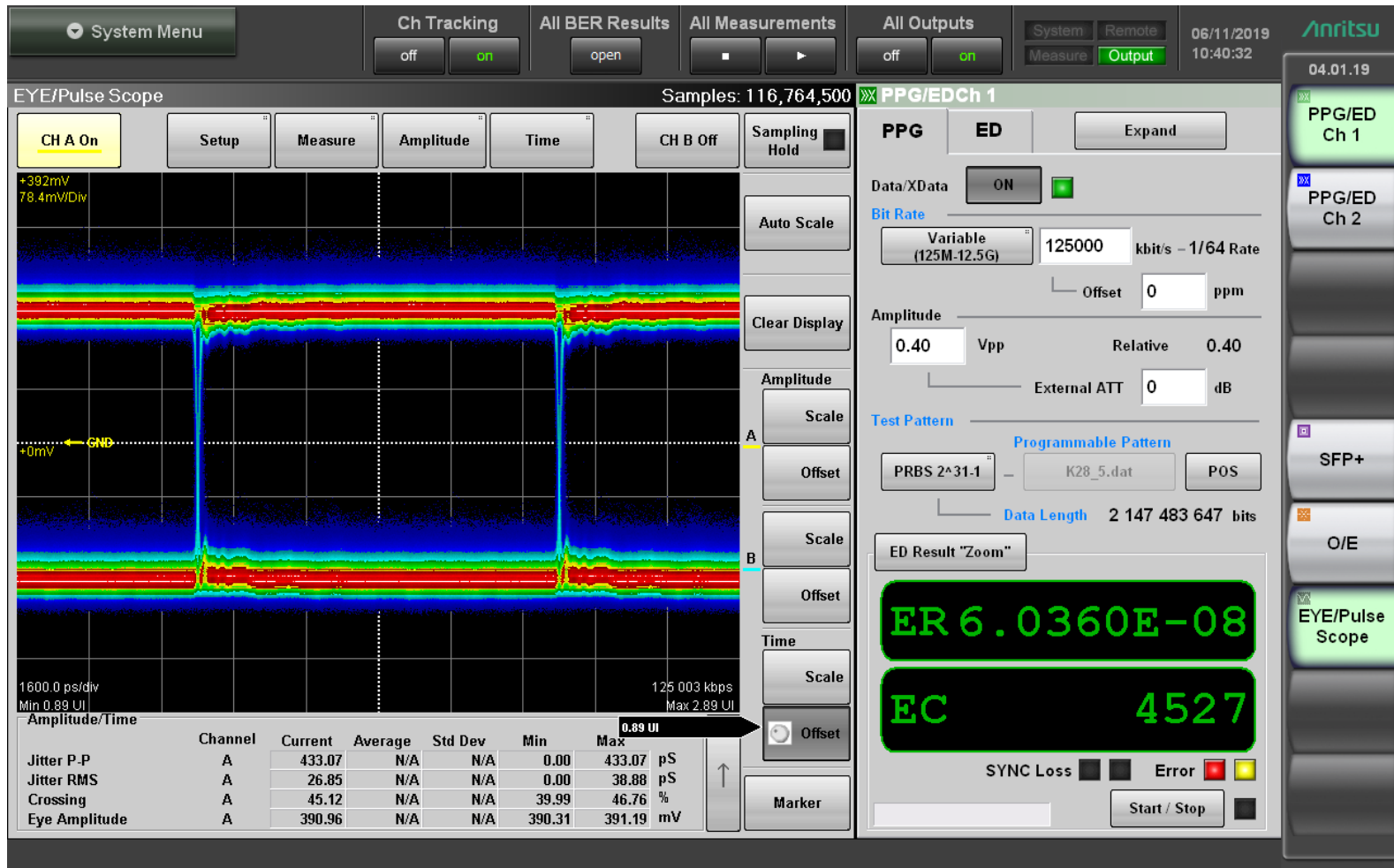

-40°C

125 Mbps with Optical Attenuation

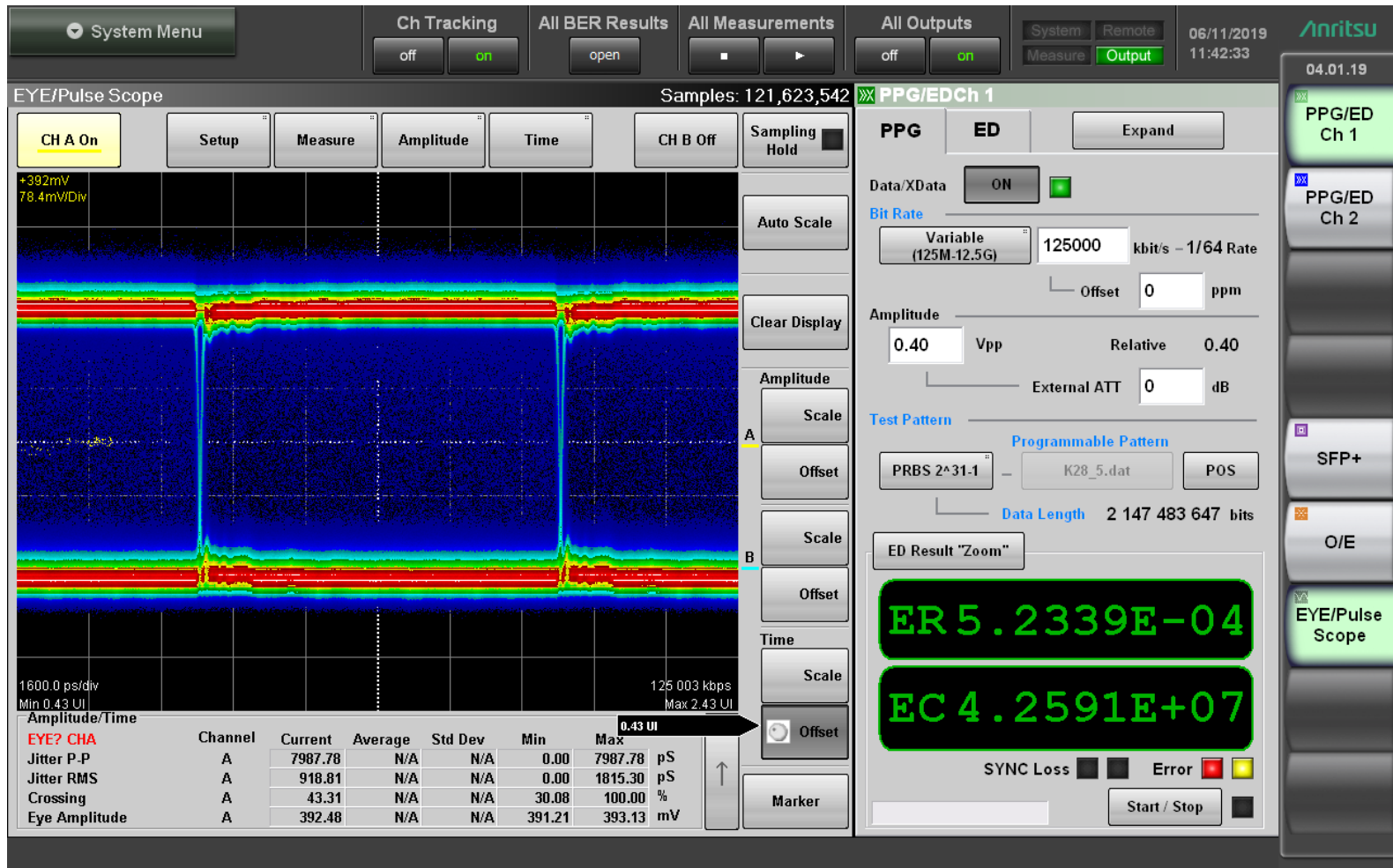

-40°C

500 Mbps No Attenuation

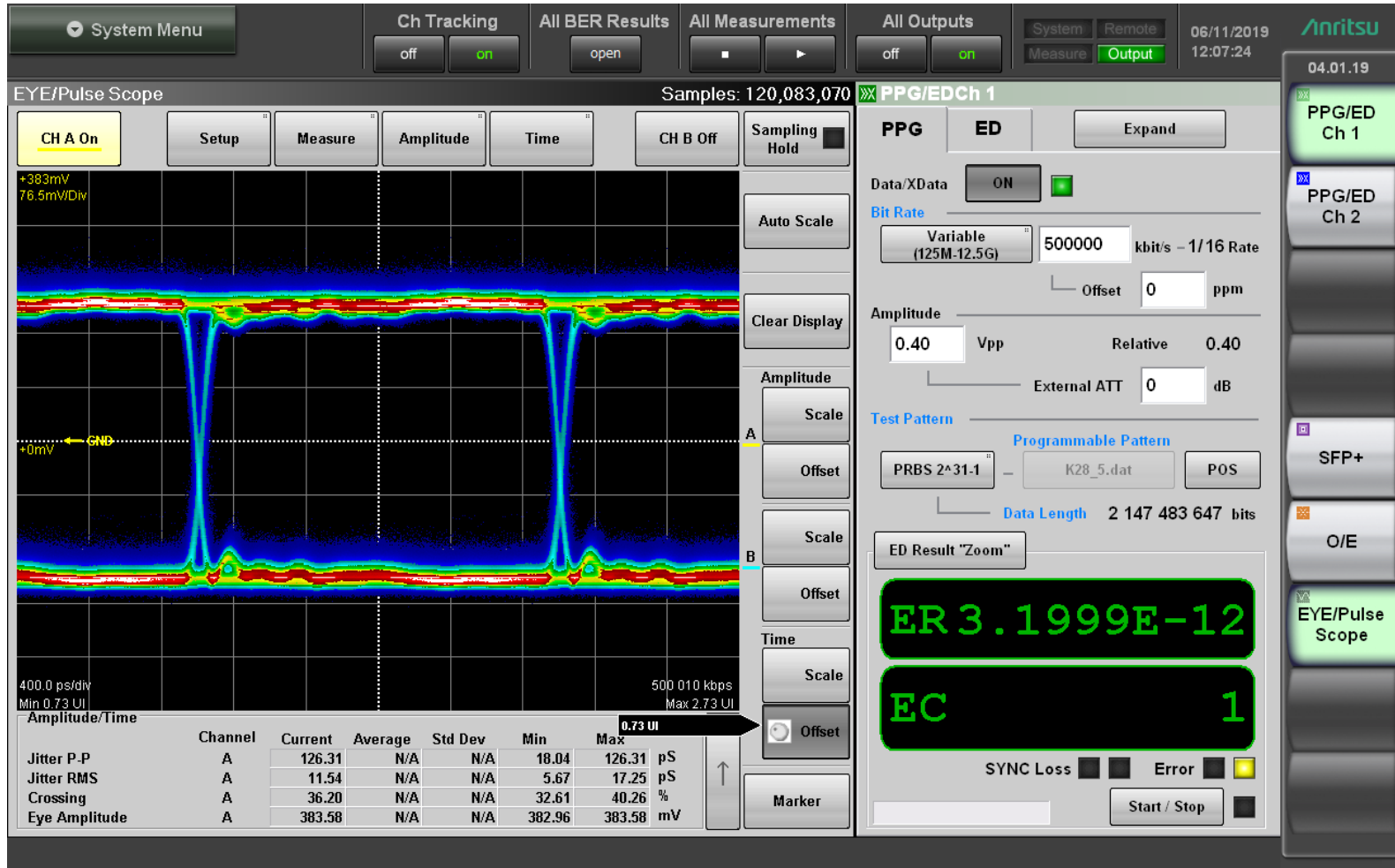

-40°C

500 Mbps with Optical Attenuation

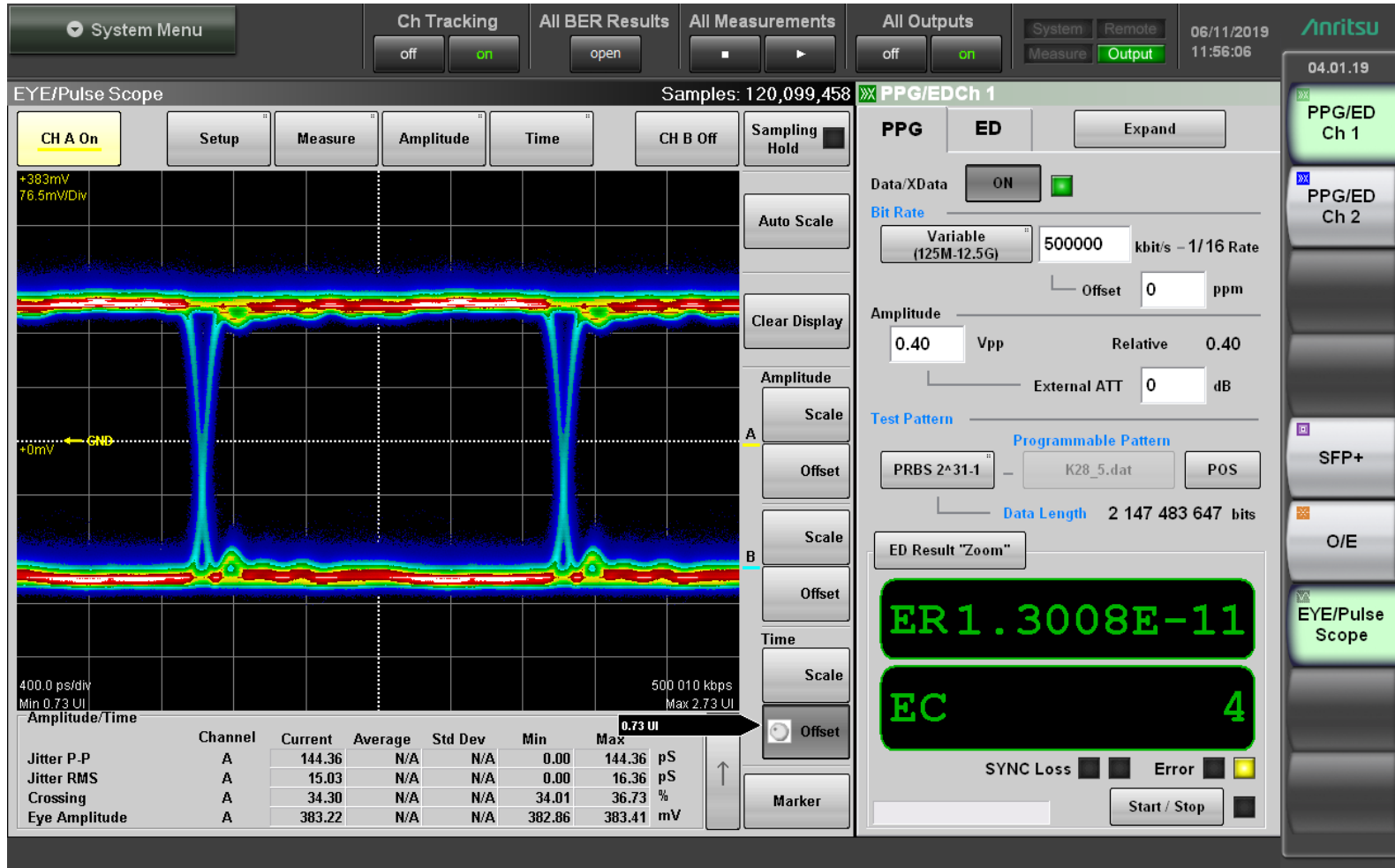

-40°C

1.25 Gbps No Attenuation

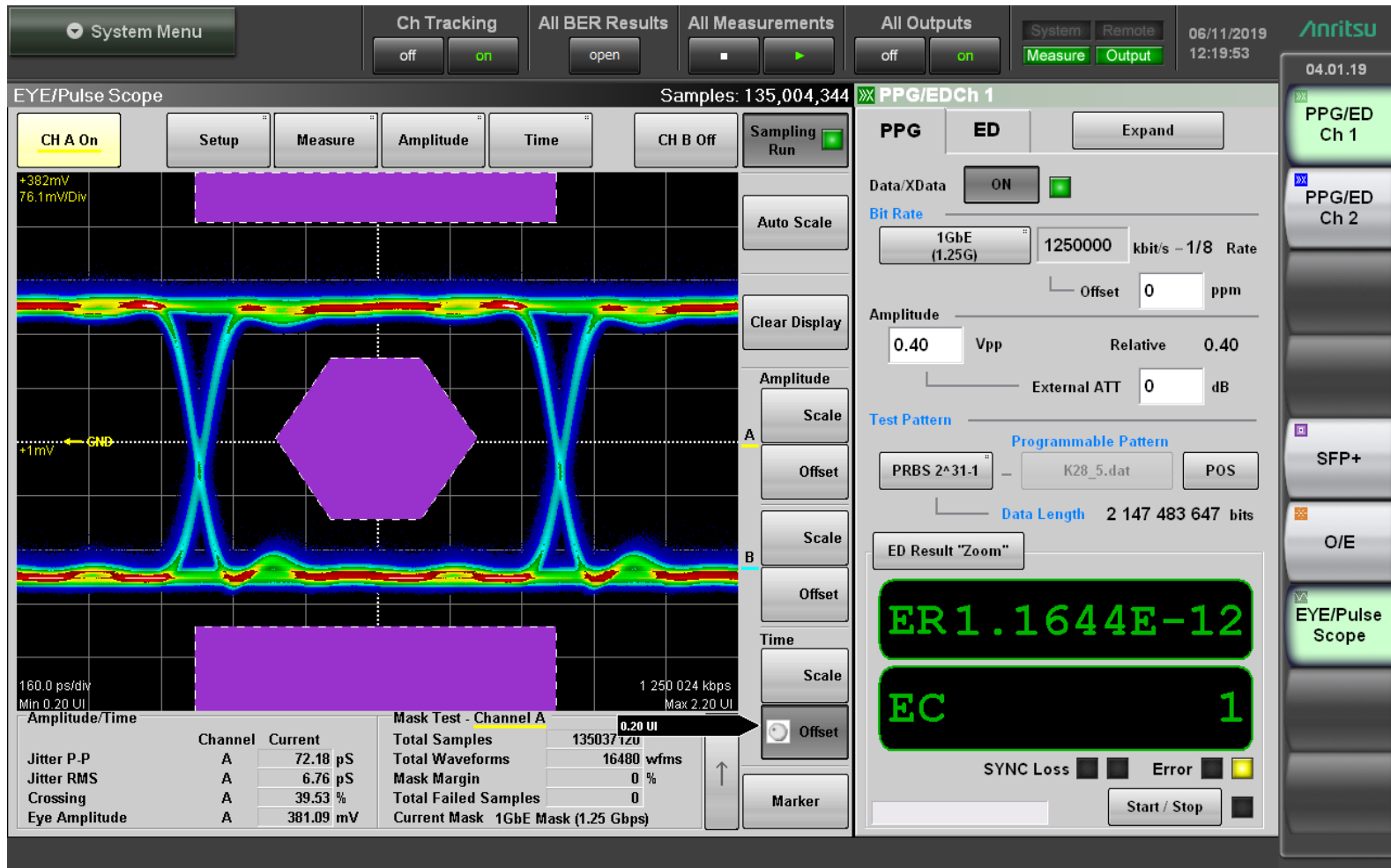

-40°C

1.25 Gbps with Optical Attenuation

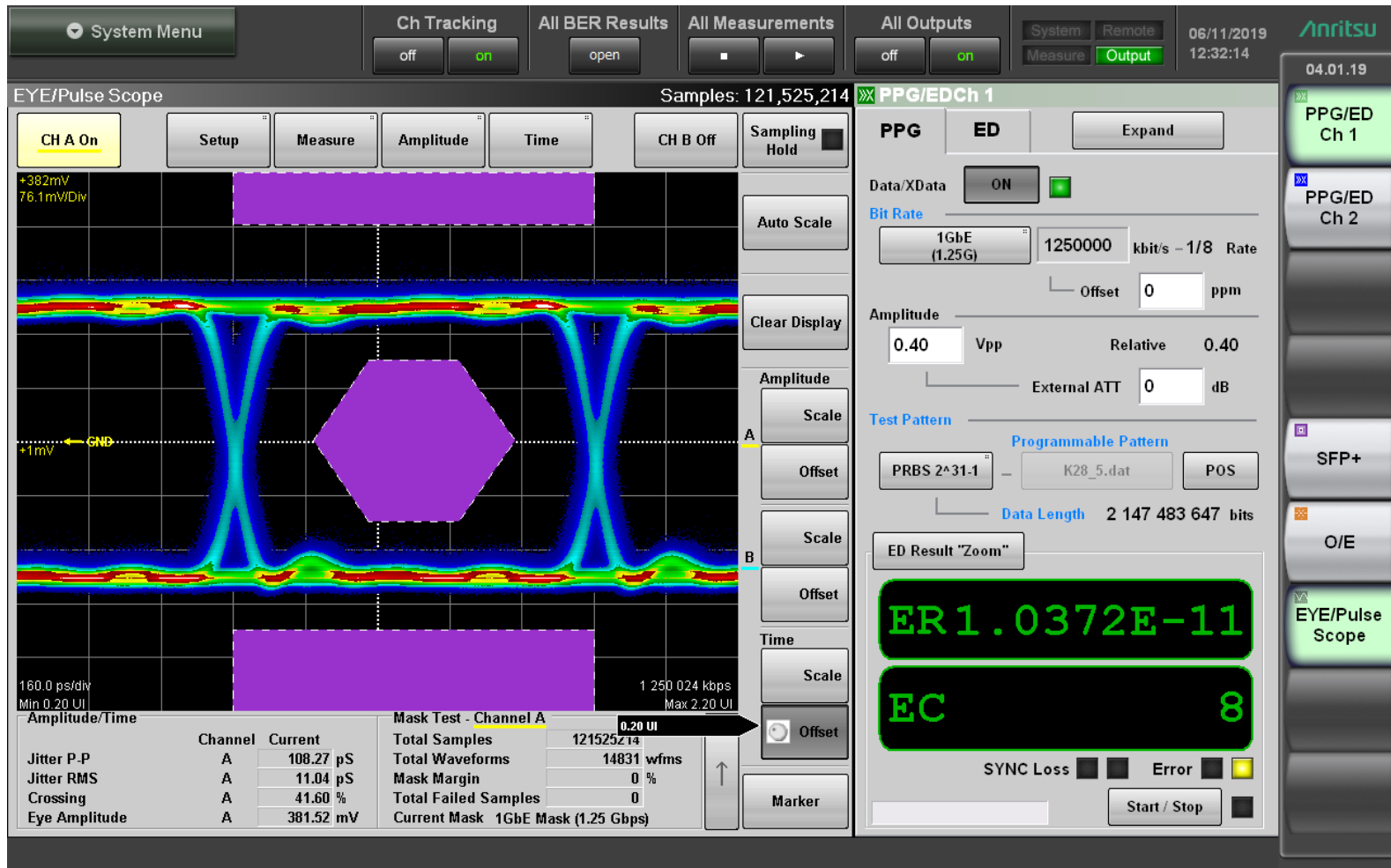

-40°C

4.25 Gbps No Attenuation

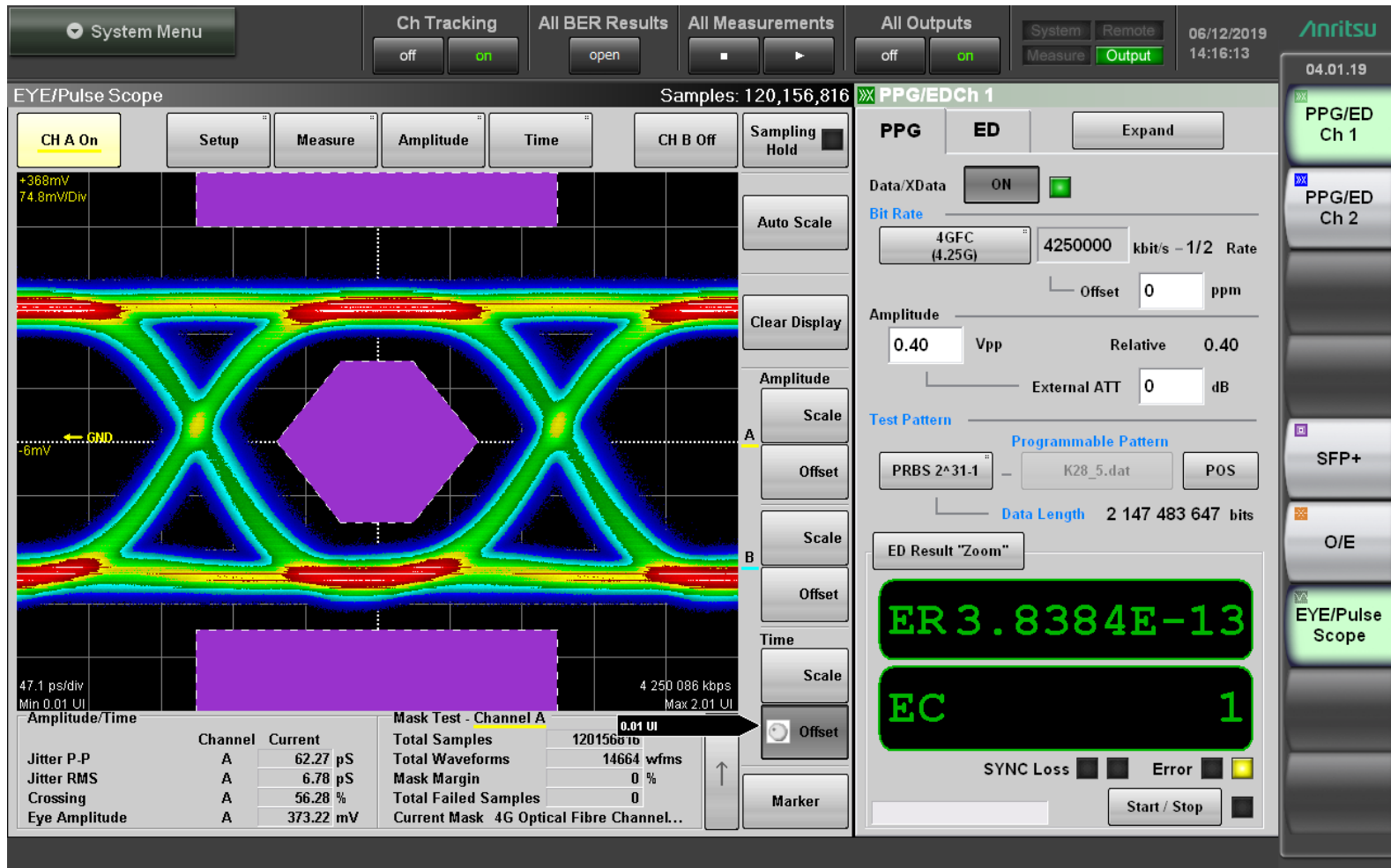

-40°C

4.25 Gbps with Optical Attenuation

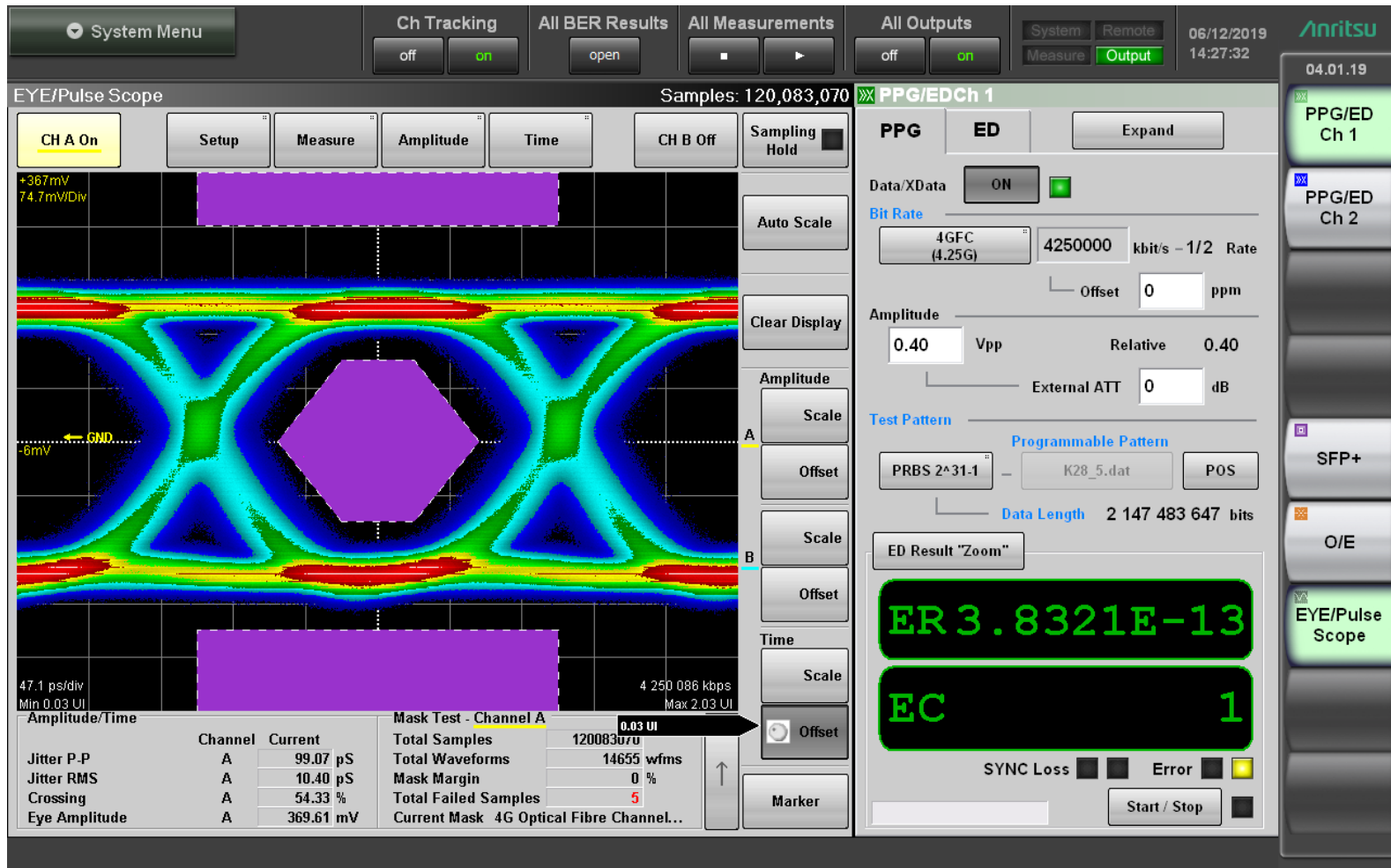

-40°C

6 Gbps No Attenuation

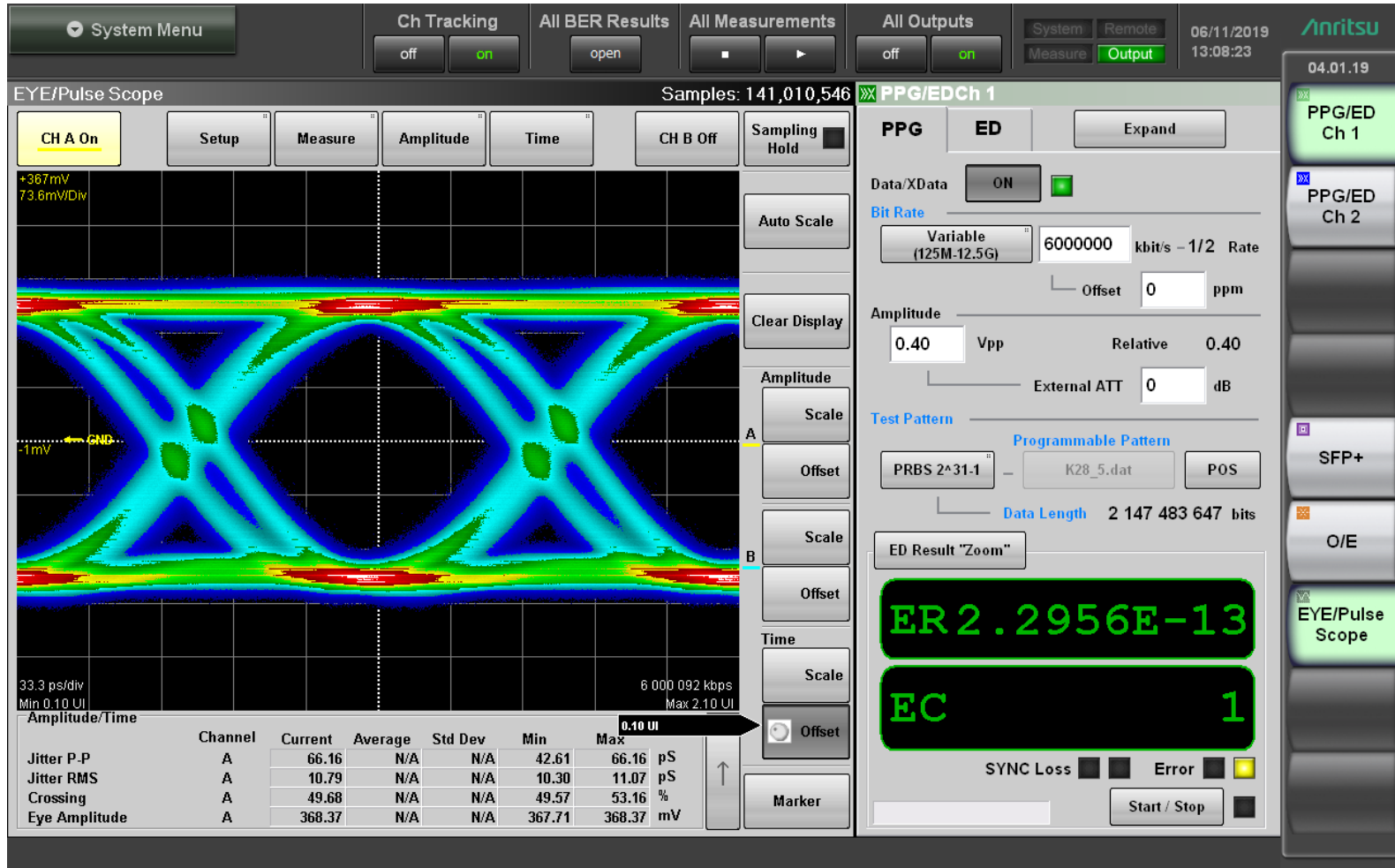

-40°C

6 Gbps with Optical Attenuation

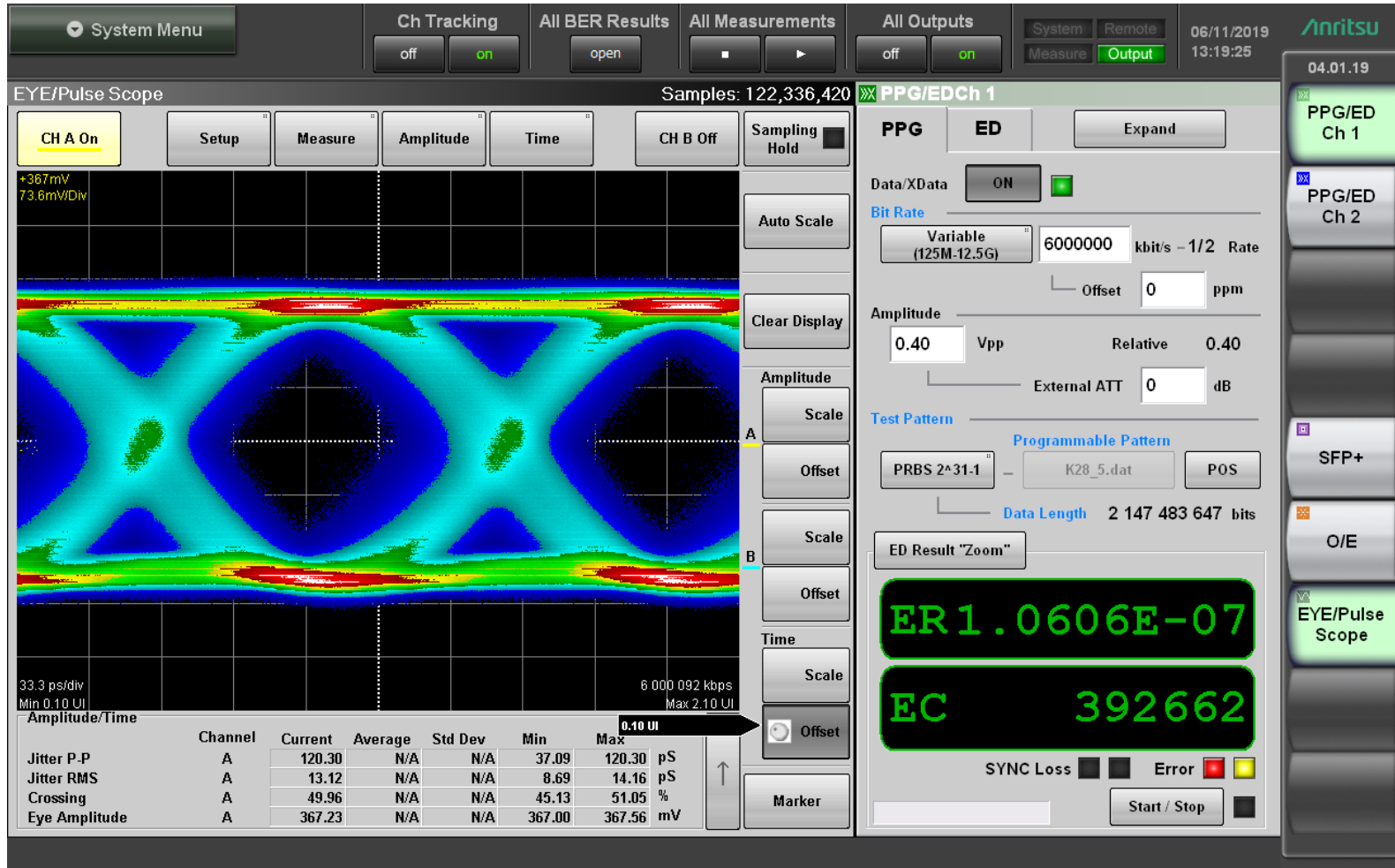

-40°C

Bit Error Rate Summary (-40°C)

Data Rate	Attenuation	BER (1 error injected manually)
125 Mbps	No	6.04E-08
125 Mbps	Yes	5.23E-04
500 Mbps	No	3.20E-12
500 Mbps	Yes	1.30E-11
1.25 Gbps	No	1.16E-12
1.25 Gbps	Yes	1.04E-11
4.25 Gbps	No	3.84E-13
4.25 Gbps	Yes	5.89E-12
6.00 Gbps	No	2.30E-13
6.00 Gbps	Yes	1.06E-07

CF-170300-034/035 Components are Rated from 155.00Mbps to 4.25Gbps but have Reasonable BER at up to 6Gbps

125 Mbps No Attenuation

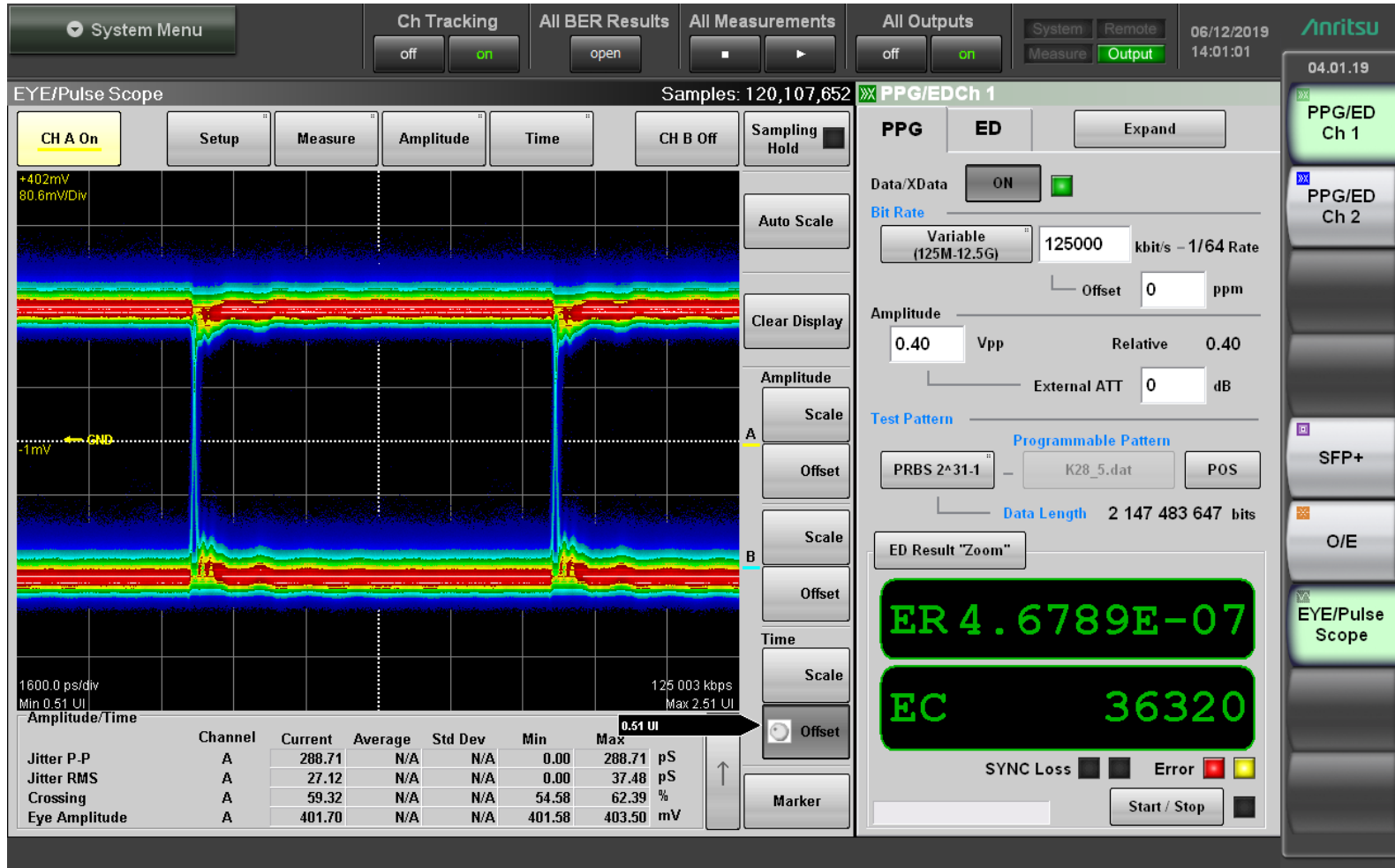

-55°C

125 Mbps with Optical Attenuation

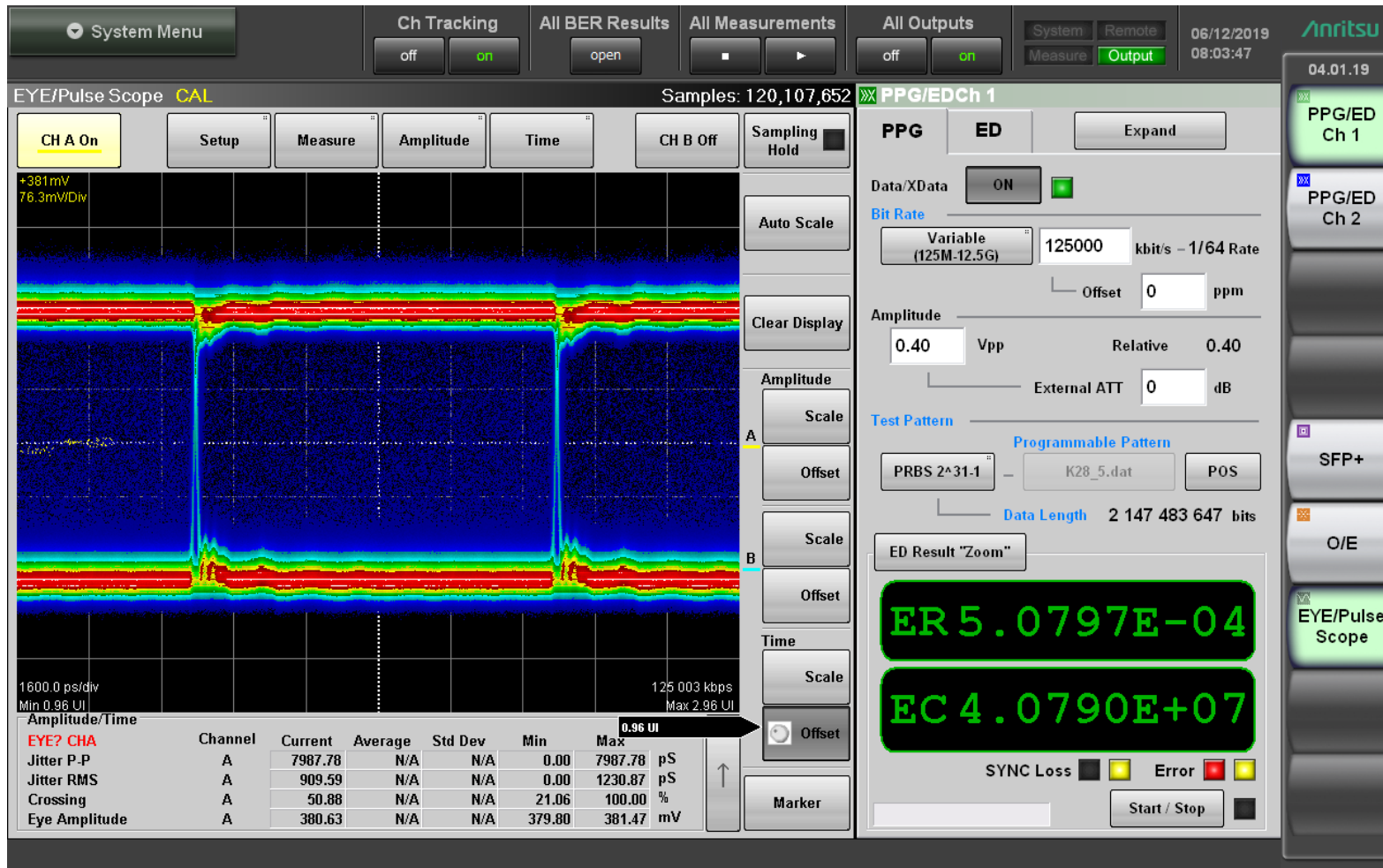

-55°C

500 Mbps No Attenuation

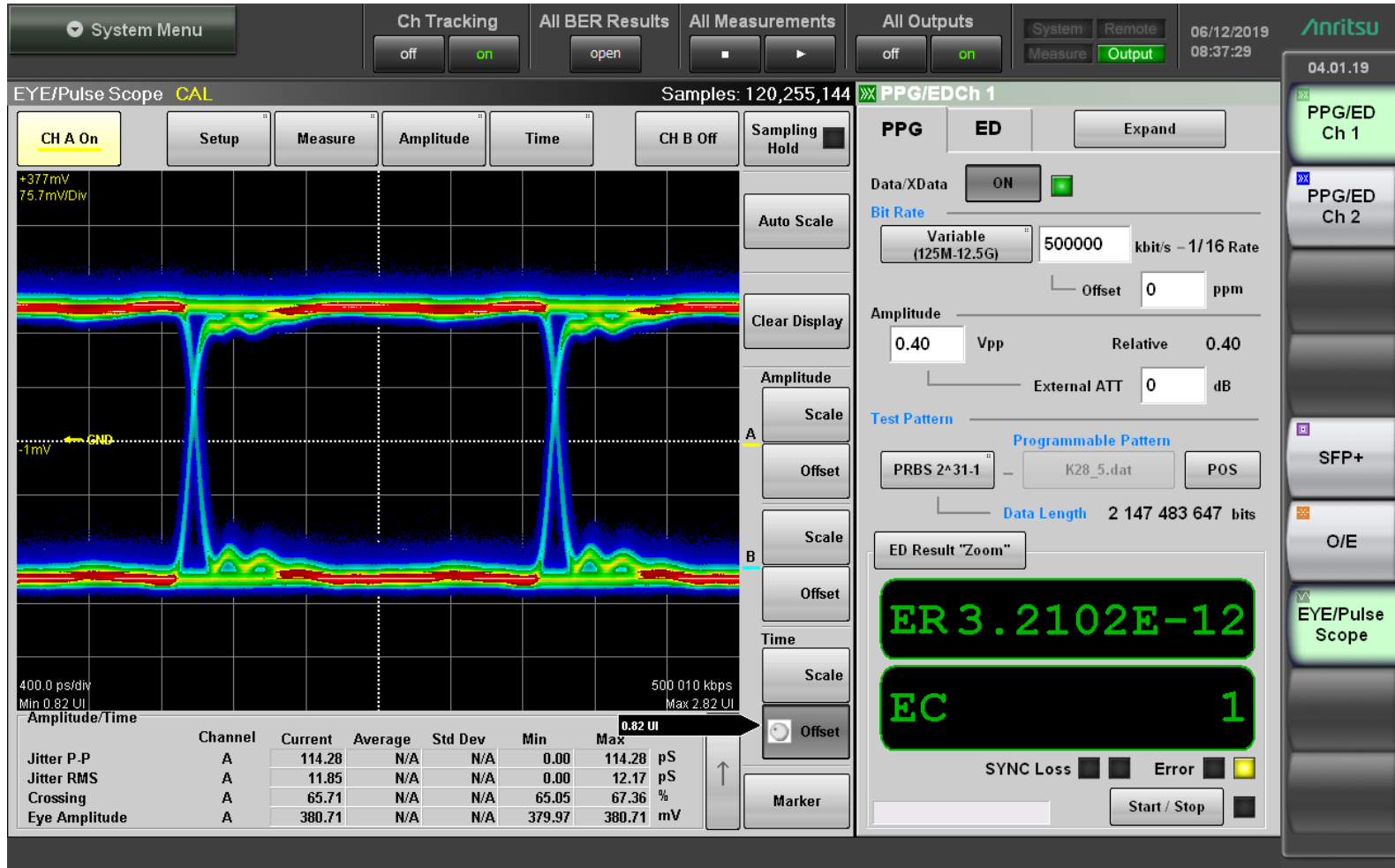

-55°C

500 Mbps with Optical Attenuation

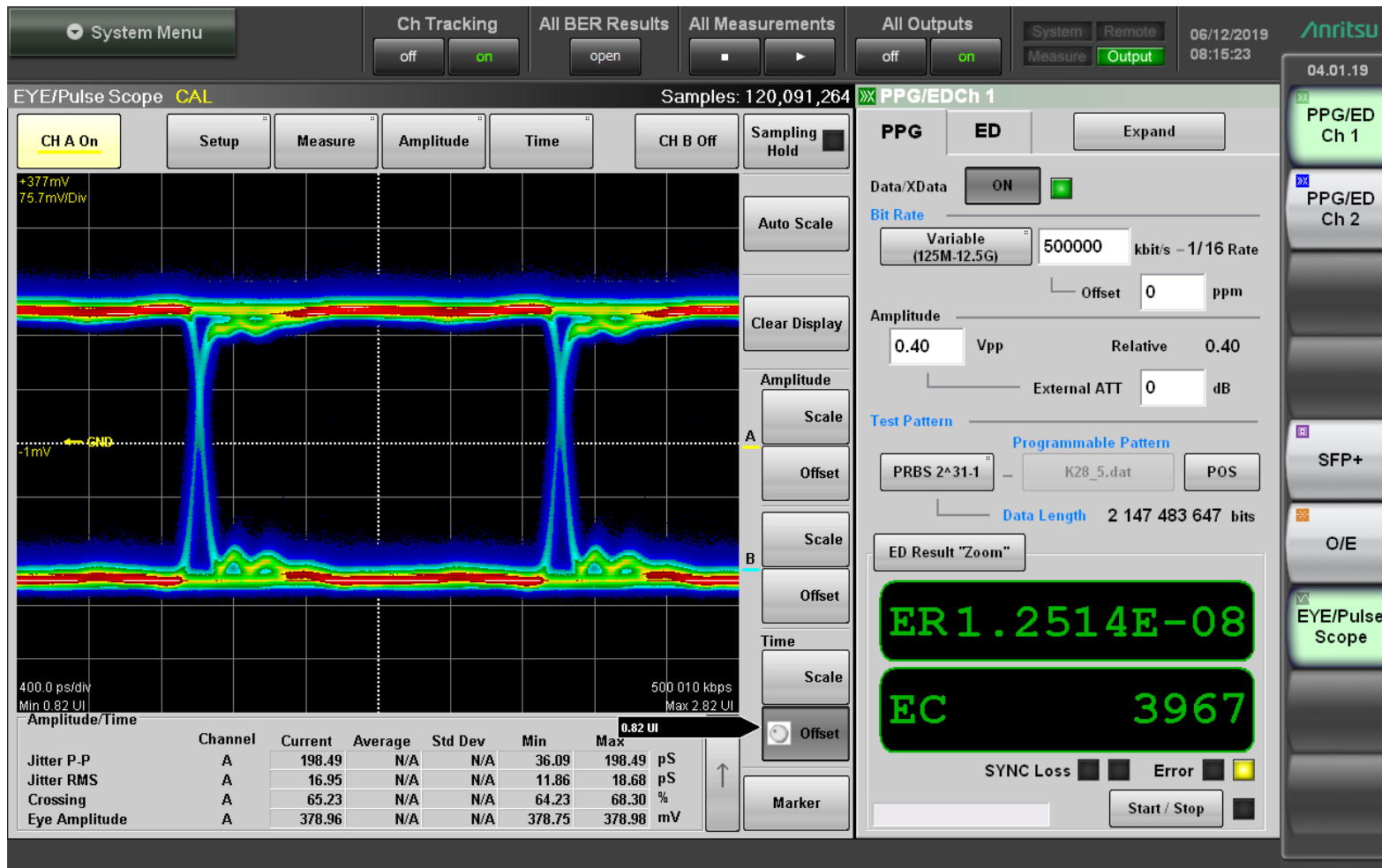

-55°C

1.25 Gbps No Attenuation

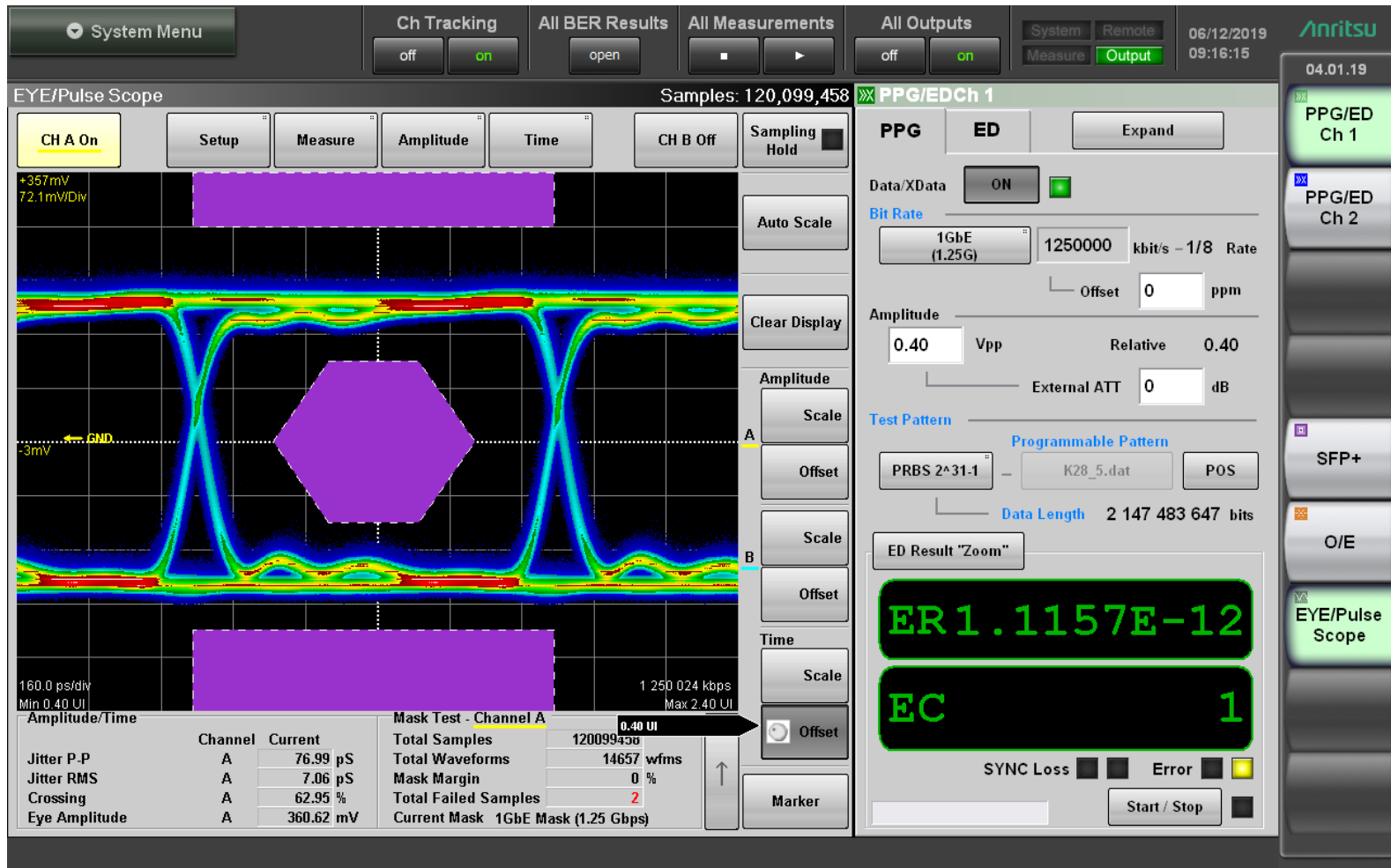

-55°C

1.25 Gbps with Optical Attenuation

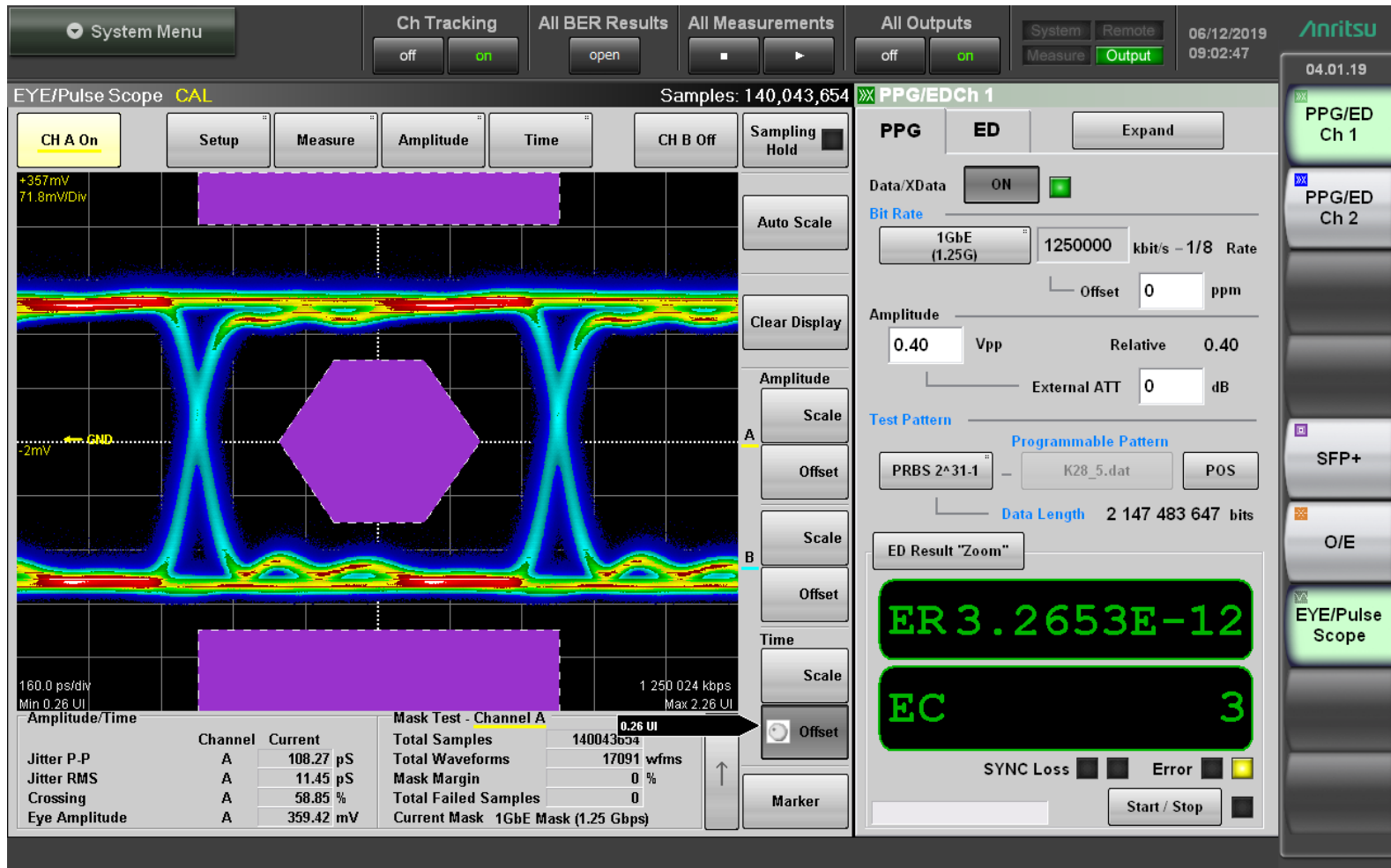

-55°C

4.25 Gbps No Attenuation

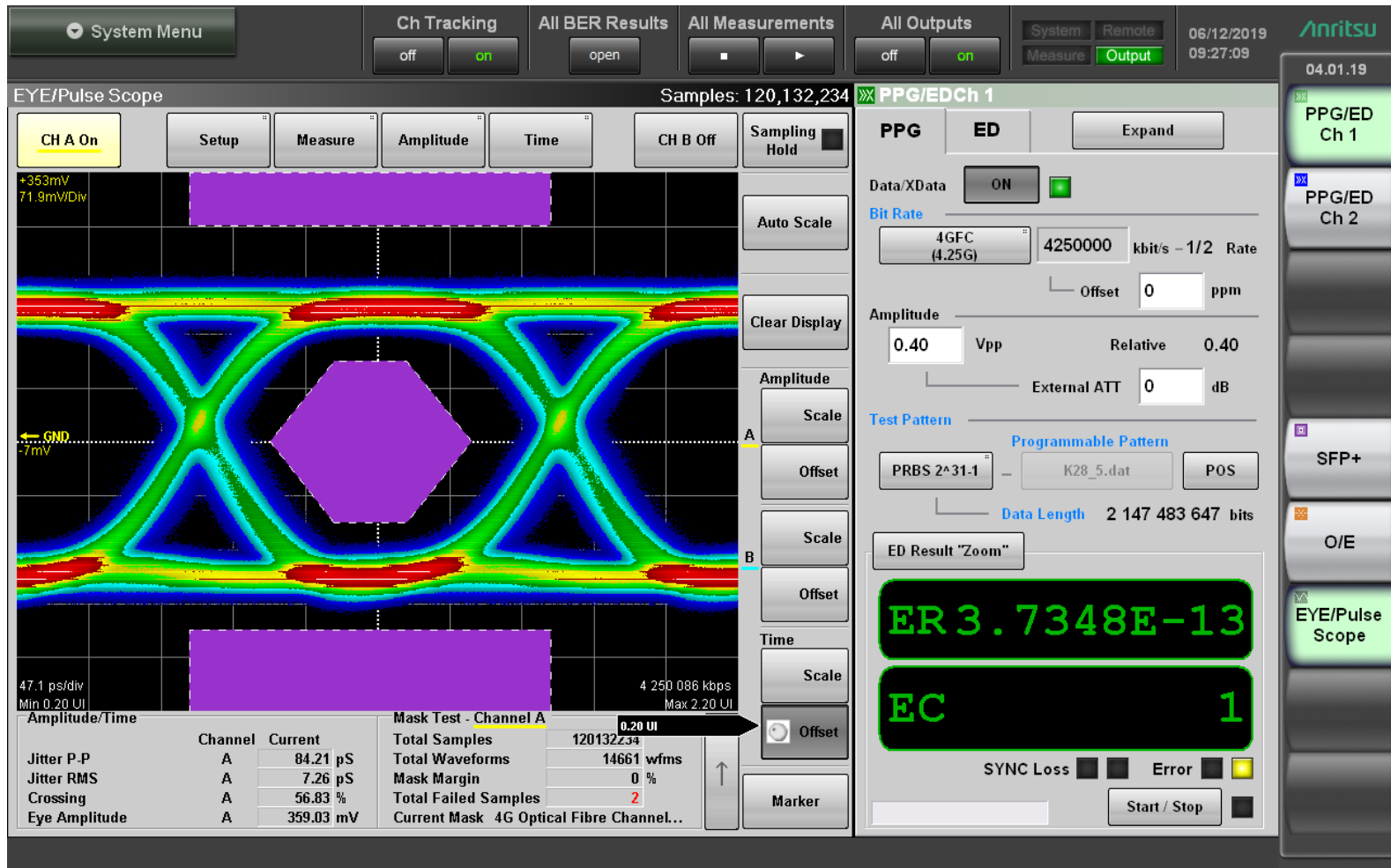

-55°C

4.25 Gbps with Optical Attenuation

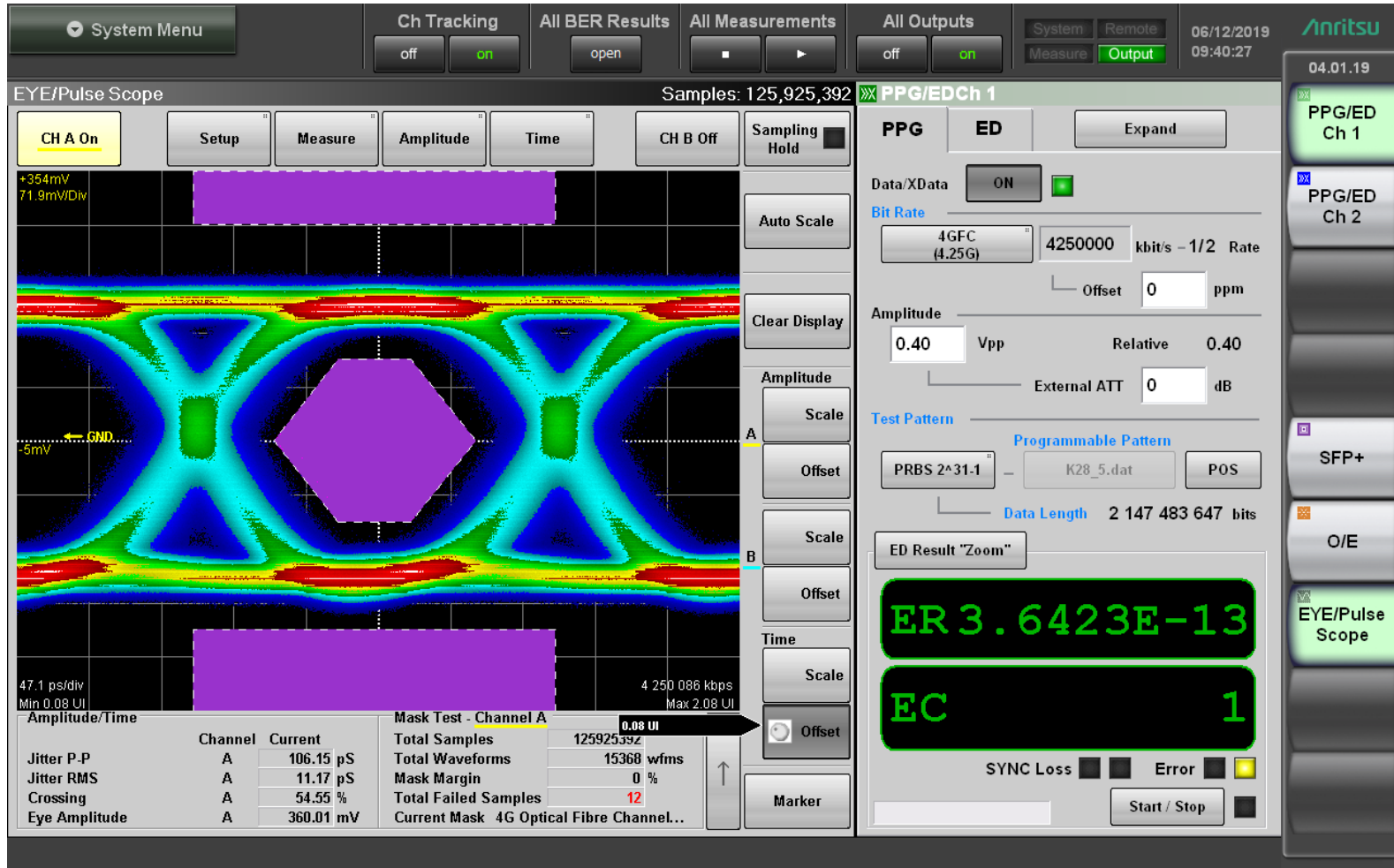

-55°C

6 Gbps No Attenuation

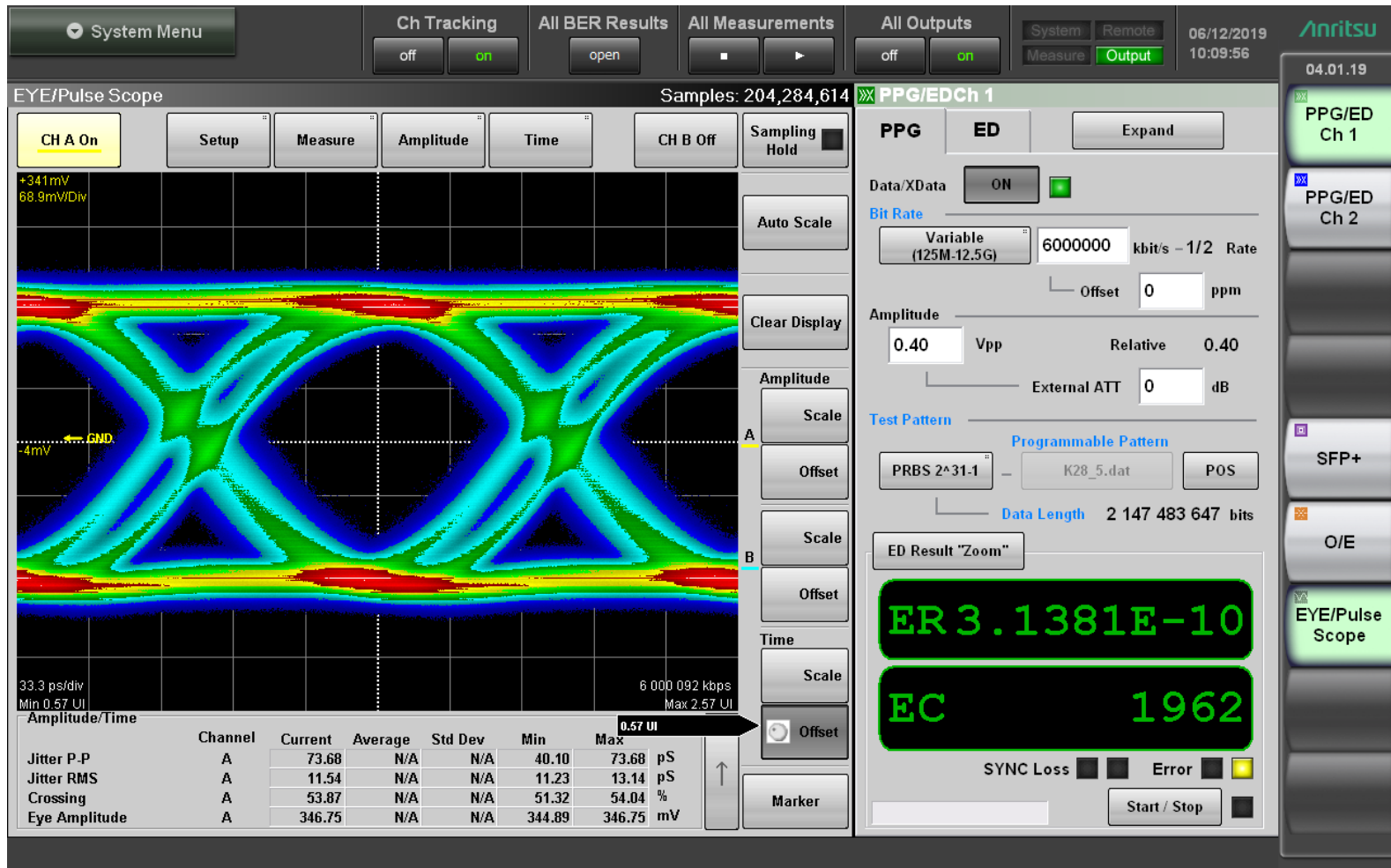

-55°C

6 Gbps with Optical Attenuation

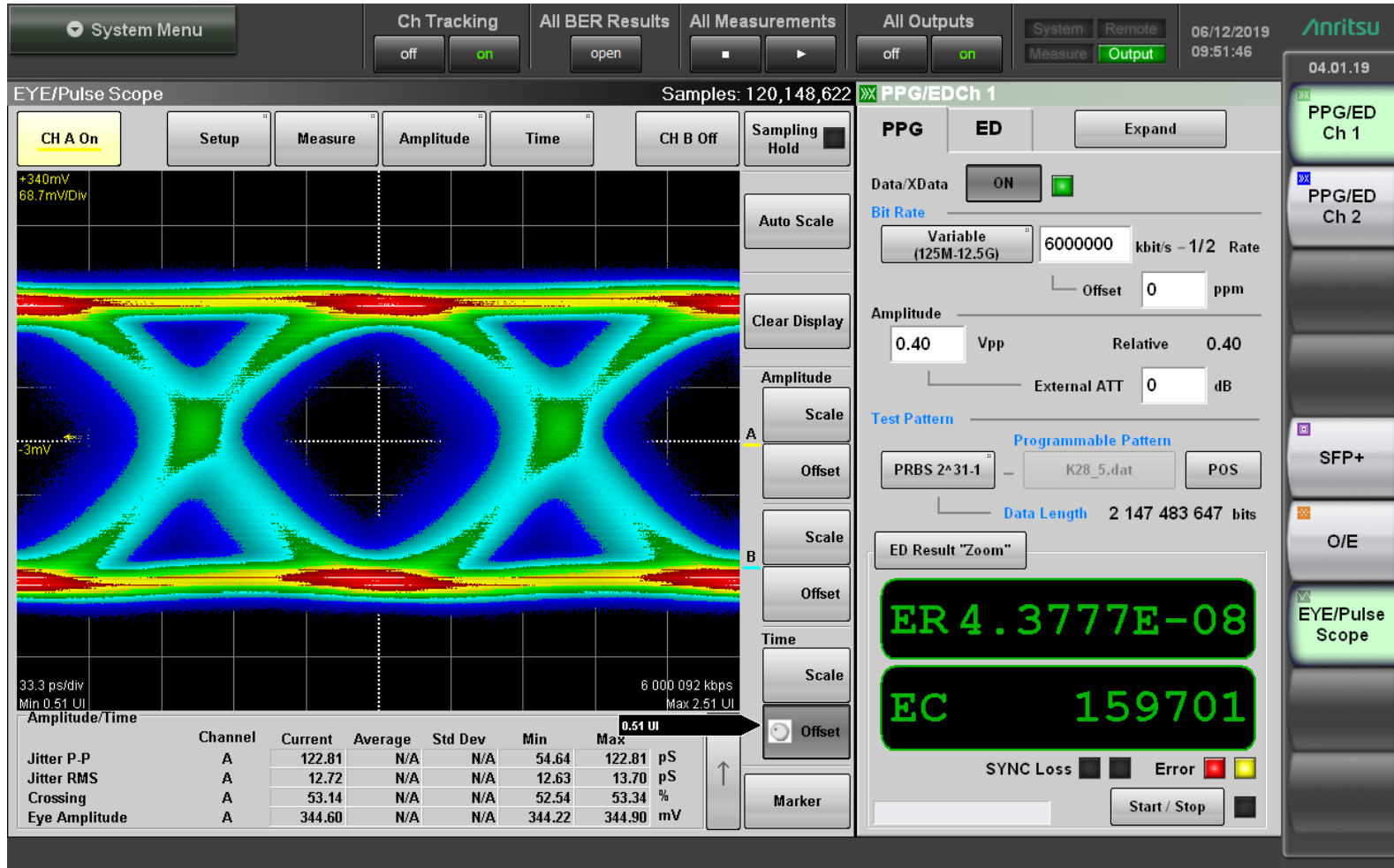

-55°C

Bit Error Rate Summary (-55°C)

Data Rate	Attenuation	BER (1 error injected manually)
125 Mbps	No	4.47E-07
125 Mbps	Yes	5.08E-04
500 Mbps	No	3.21E-12
500 Mbps	Yes	1.25E-08
1.25 Gbps	No	1.12E-12
1.25 Gbps	Yes	3.27E-12
4.25 Gbps	No	3.73E-13
4.25 Gbps	Yes	3.64E-13
6.00 Gbps	No	3.14E-10
6.00 Gbps	Yes	4.38E-08

CF-170300-034/035 Components are Rated from 155.00Mbps to 4.25Gbps but have Reasonable BER at up to 6Gbps

The image features a blue background with a grid pattern and various abstract geometric shapes, including circles and lines. The word "Amphenol" is written in a large, white, sans-serif font. Below it, the tagline "ENABLING THE ELECTRONICS REVOLUTION" is written in a smaller, white, sans-serif font. In the bottom right corner, there are several small, light blue icons, including arrows and circles.

Amphenol

ENABLING THE ELECTRONICS REVOLUTION

FiberQuad BER Summary Across Temperature

BER Summary No Attenuation

Temperature (in °C)	Data Rate	Attenuation	BER (1 error injected manually)
100	125 Mbps	No	1.23E-11
	500 Mbps	No	3.16E-12
	1.25 Gbps	No	1.30E-12
	4.25 Gbps	No	3.68E-13
	6.00 Gbps	No	3.44E-03
85	125 Mbps	No	6.61E-07
	500 Mbps	No	1.71E-10
	1.25 Gbps	No	1.27E-12
	4.25 Gbps	No	3.82E-13
	6.00 Gbps	No	6.67E-07
23	125 Mbps	No	1.16E-08
	500 Mbps	No	2.78E-12
	1.25 Gbps	No	8.72E-13
	4.25 Gbps	No	2.10E-13
	6.00 Gbps	No	1.98E-13
-40	125 Mbps	No	6.04E-08
	500 Mbps	No	3.20E-12
	1.25 Gbps	No	1.16E-12
	4.25 Gbps	No	3.84E-13
	6.00 Gbps	No	2.30E-13
-55	125 Mbps	No	4.47E-07
	500 Mbps	No	3.21E-12
	1.25 Gbps	No	1.12E-12
	4.25 Gbps	No	3.73E-13
	6.00 Gbps	No	3.14E-10

BER Summary With Attenuation

Temperature (in °C)	Data Rate	Attenuation	BER (1 error injected manually)
100	125 Mbps	Yes	1.38E-08
	500 Mbps	Yes	1.25E-11
	1.25 Gbps	Yes	6.44E-13
	4.25 Gbps	Yes	3.90E-11
	6.00 Gbps	Yes	3.03E-03
85	125 Mbps	Yes	1.84E-07
	500 Mbps	Yes	3.14E-12
	1.25 Gbps	Yes	1.28E-12
	4.25 Gbps	Yes	3.85E-13
	6.00 Gbps	Yes	6.92E-09
23	125 Mbps	Yes	1.42E-10
	500 Mbps	Yes	2.44E-12
	1.25 Gbps	Yes	1.00E-12
	4.25 Gbps	Yes	2.57E-12
	6.00 Gbps	Yes	5.40E-09
-40	125 Mbps	Yes	5.23E-04
	500 Mbps	Yes	1.30E-11
	1.25 Gbps	Yes	1.04E-11
	4.25 Gbps	Yes	5.89E-12
	6.00 Gbps	Yes	1.06E-07
-55	125 Mbps	Yes	5.08E-04
	500 Mbps	Yes	1.25E-08
	1.25 Gbps	Yes	3.27E-12
	4.25 Gbps	Yes	3.64E-13
	6.00 Gbps	Yes	4.38E-08

Amphenol

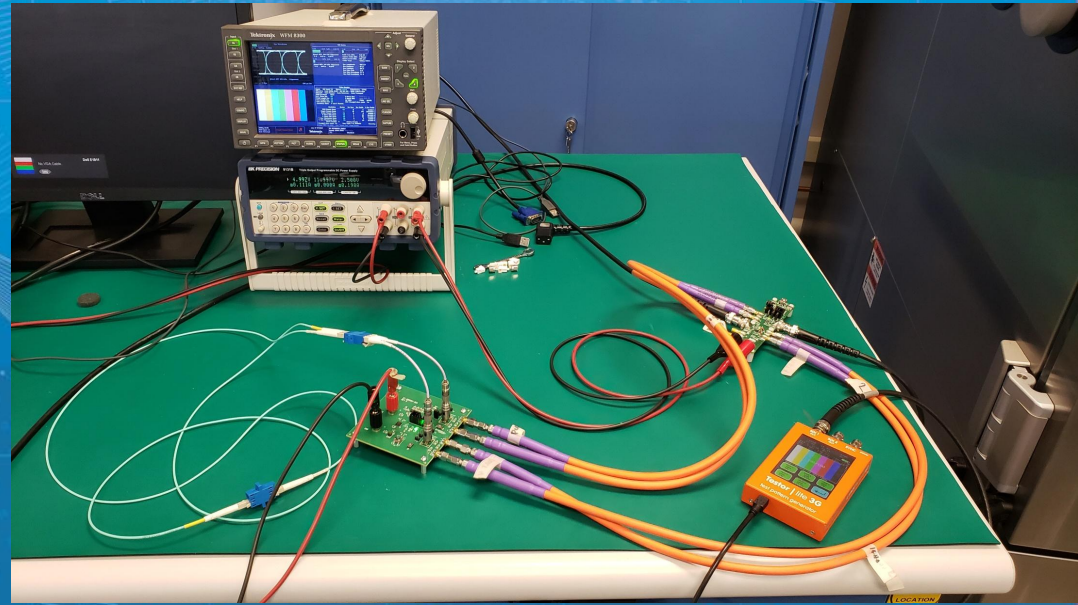

ENABLING THE ELECTRONICS REVOLUTION

FiberQuad SDI Video Testing

Video Performance Testing

- Tested at temperatures of 100, 85, -40, and -55 °C
- Tested SDI at 3 different resolutions:
 - 3G-SDI: 1920x1080 @ 60Hz (2.97 Gbps)
 - HD-SDI: 1920x1080 @ 30Hz (1.485 Gbps)
 - SD-SDI: 720x480 @ 59.94Hz (270 Mbps)
- Tested without optical attenuation, attenuated to -9 dBm of optical power, and attenuated to -15 dBm of optical power
- Duration of each test was roughly 10 minutes

Test Setup Block Diagram (Video)

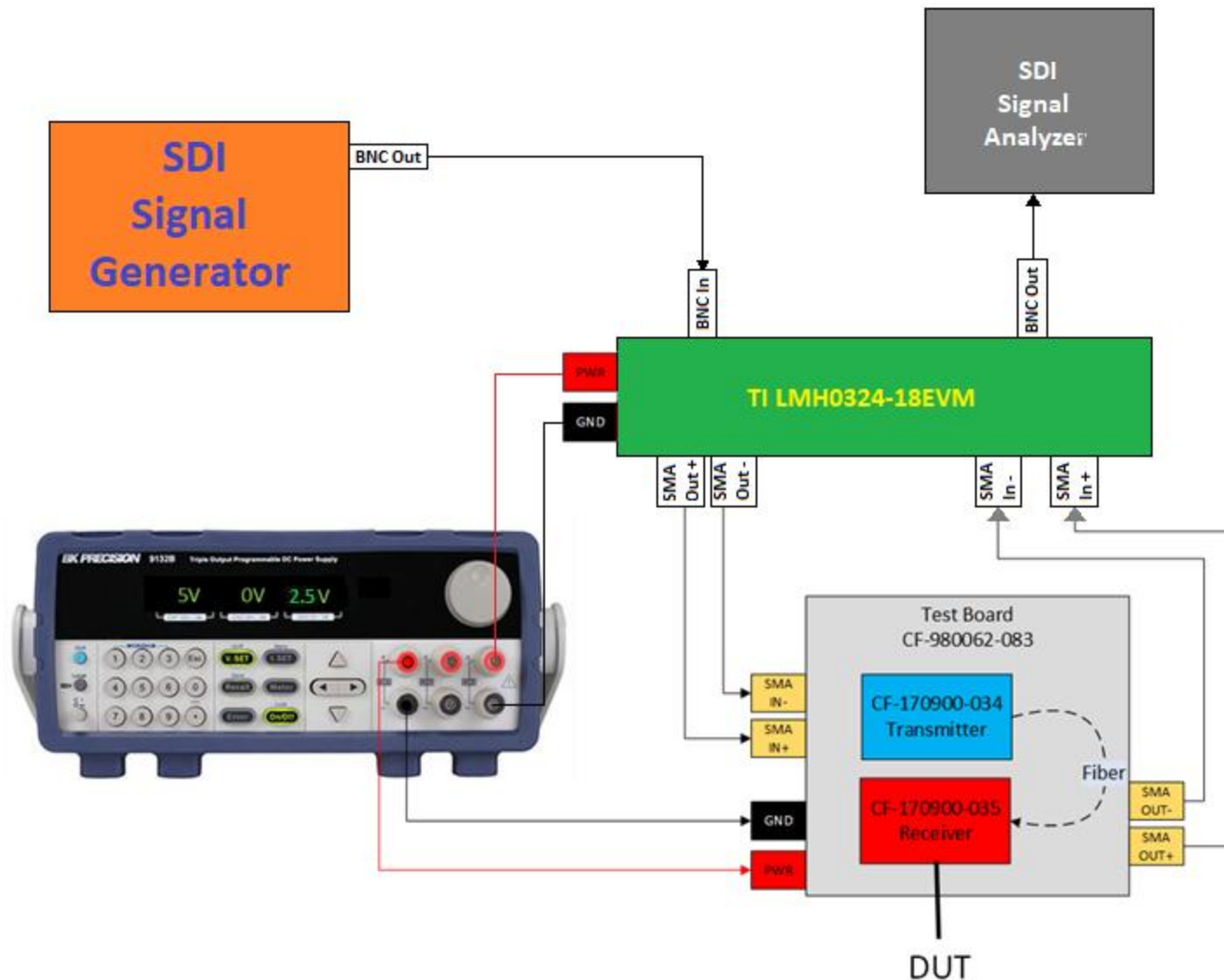

Video Performance Test Setup

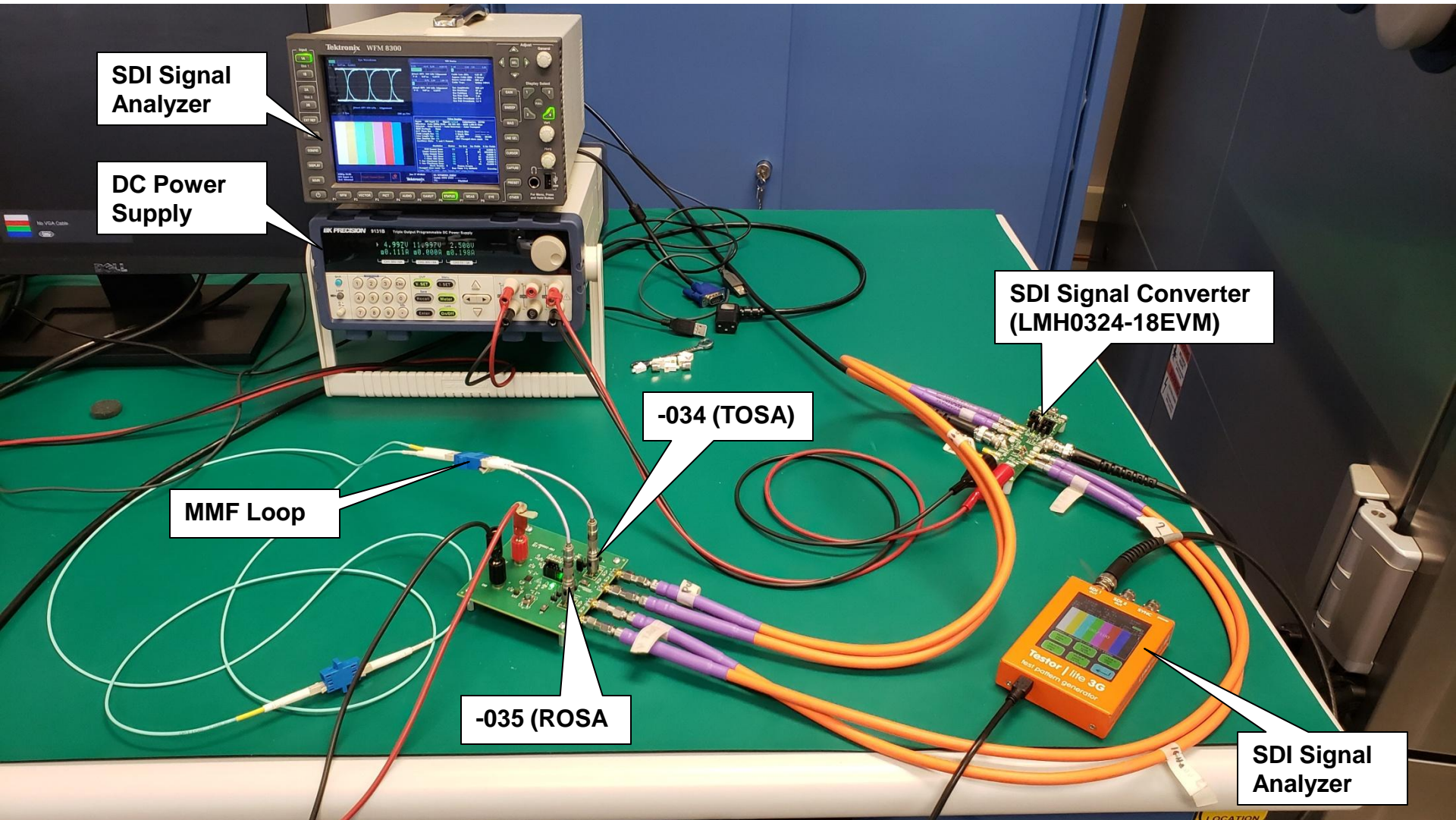

SDI Signal Analyzer

DC Power Supply

SDI Signal Converter (LMH0324-18EVM)

-034 (TOSA)

MMF Loop

-035 (ROSA)

SDI Signal Analyzer

Video Performance Test Setup

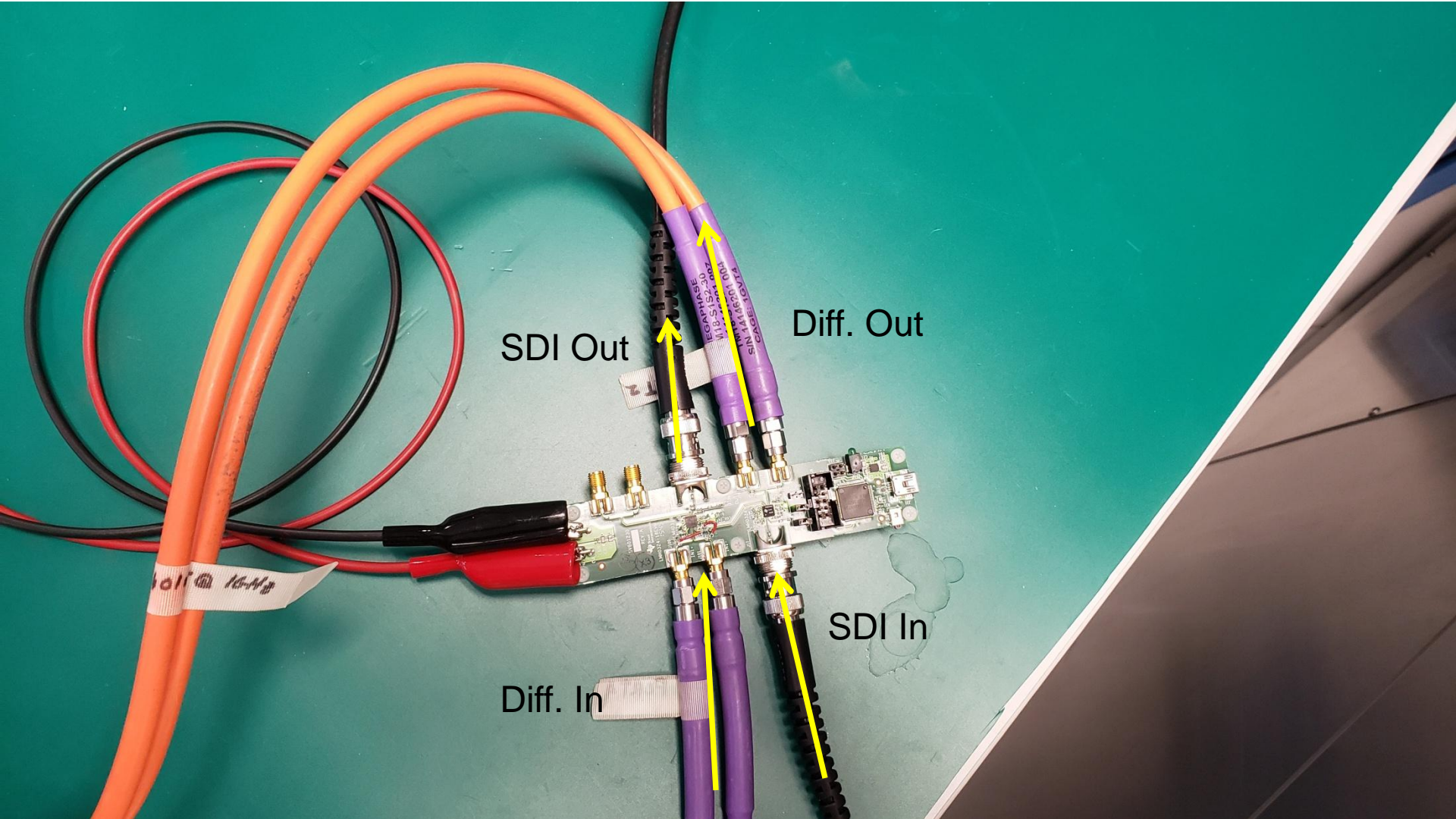

3G-SDI No Attenuation



100°C

3G-SDI @ -9 dBm



100°C

3G-SDI @ -15 dBm



100°C

HD-SDI No Attenuation



100°C

HD-SDI @ -9 dBm



100°C

HD-SDI @ -15 dBm



100°C

SD-SDI No Attenuation



100°C

SD-SDI @ -9 dBm



100°C

SD-SDI @ -15 dBm



100°C

3G-SDI No Attenuation



85°C

3G-SDI @ -9 dBm



85°C

3G-SDI @ -15 dBm



85°C

HD-SDI No Attenuation



85°C

HD-SDI @ -9 dBm



85°C

HD-SDI @ -15 dBm



85°C

SD-SDI No Attenuation



85°C

SD-SDI @ -9 dBm



85°C

SD-SDI @ -15 dBm



85°C

3G-SDI No Attenuation



3G-SDI @ -9 dBm



3G-SDI @ -15 dBm



23°C

HD-SDI No Attenuation



HD-SDI @ -9 dBm



23°C

HD-SDI @ -15 dBm



23°C

SD-SDI No Attenuation



SD-SDI @ -9 dBm



23°C

SD-SDI @ -15 dBm



23°C

3G-SDI No Attenuation



-40°C

3G-SDI @ -9 dBm



-40°C

3G-SDI @ -15 dBm



-40°C

HD-SDI No Attenuation



-40°C

HD-SDI @ -9 dBm



-40°C

HD-SDI @ -15 dBm



-40°C

SD-SDI No Attenuation



-40°C

SD-SDI @ -9 dBm



-40°C

SD-SDI @ -15 dBm



-40°C

3G-SDI No Attenuation



-55°C

3G-SDI @ -9 dBm



-55°C

3G-SDI @ -15 dBm



-55°C

HD-SDI No Attenuation



-55°C

HD-SDI @ -9 dBm



-55°C

HD-SDI @ -15 dBm



-55°C

SD-SDI No Attenuation



-55°C

SD-SDI @ -9 dBm



-55°C

SD-SDI @ -15 dBm

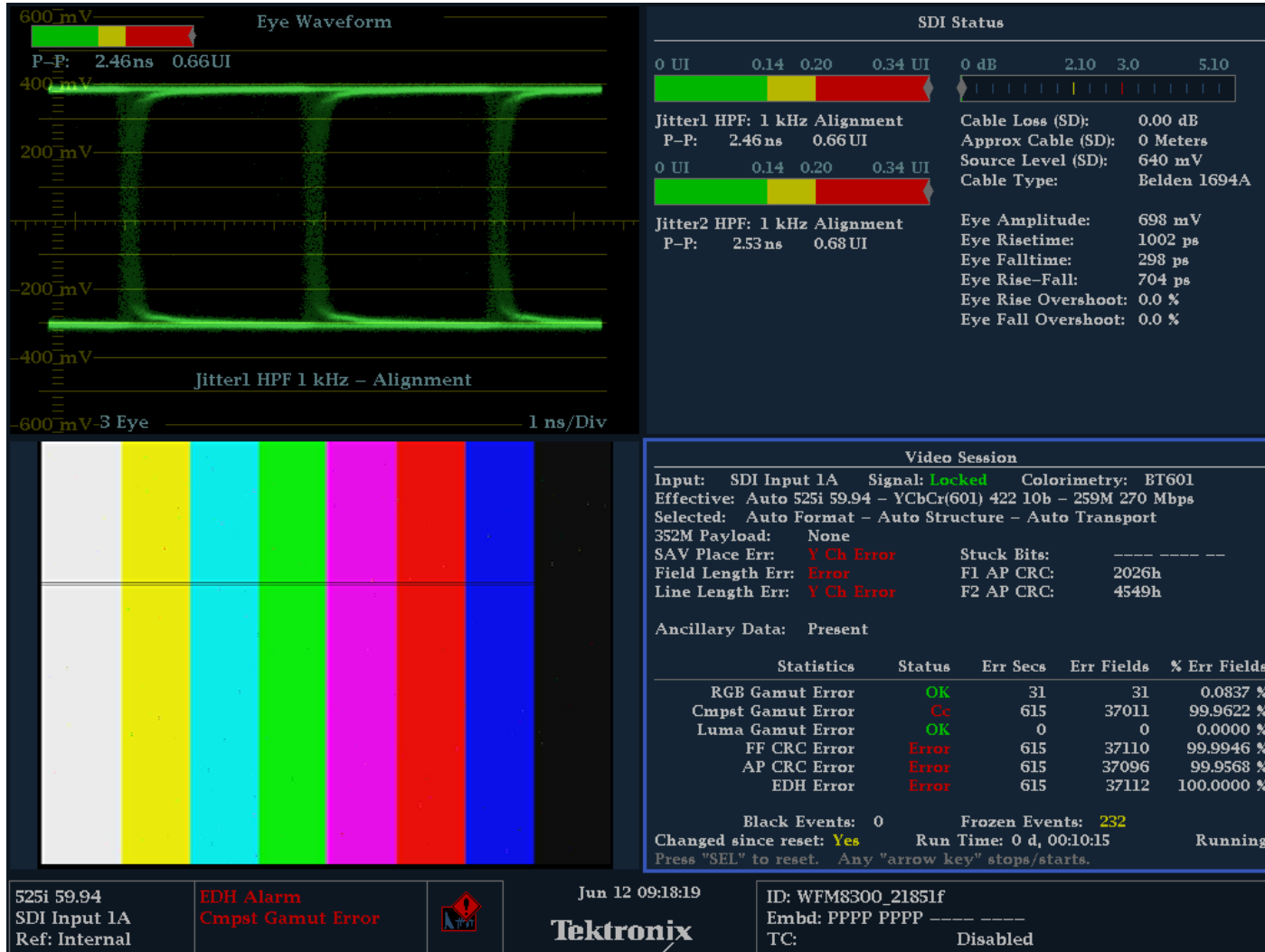

-55°C

SDI CRC Errors

	3G-SDI			HD-SDI			SD-SDI		
Signal Strength (dBm)	0	-9	-15	0	-9	-15	0	-9	-15
100°C	0	0	0	0	0	0	0	0	0
85°C	0	0	0	0	0	0	0	0	0
23°C	0	0	0	0	0	0	0	0	54
-40°C	0	0	0	0	0	0	0	0	1027
-55°C	0	0	2	0	0	82	0	0	615

Each test was performed for at least 10 minutes.

The background of the slide is a vibrant blue with a complex, futuristic design. It features a grid of thin white lines, several large, semi-transparent circular patterns resembling radar or data scans, and flowing, wavy lines that suggest motion or data flow. In the upper left, there is a horizontal line of binary code (0s and 1s).

Amphenol

High Speed Solutions

ENABLING THE ELECTRONICS REVOLUTION

Contact Us

Questions / Comments

Contact Information

- **Jared Sibrava**
 - 607-643-1845
 - jsibrava@amphenol-aao.com
- **Joseph Rothrock**
 - 607-643-8009
 - jrothrock@amphenol-aao.com

Datasheet

- <https://www.amphenol-aerospace.com/pdf/pds/FiberQuad.pdf>

Sample Kits

- To include a kit of the transmitter, receiver, test board, and fiber cables provided upon request



Sample Kit Contents



Transmitter



Receiver



Test Cables

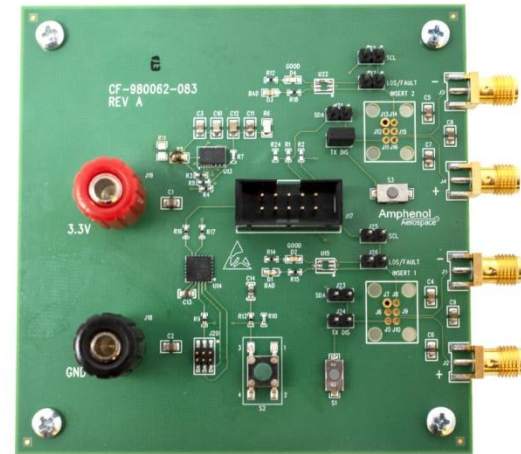

Test Board

