

Micro Bayonet Connectors

For Aerospace Applications



Overview, Applications and Features

Amphenol's Bantam Product Series was inspired by the need to replace D-Sub and traditional high cost connectors with a low cost alternative while maintaining the high performance demanded by today's flight critical applications

Bantam

Bantam HD

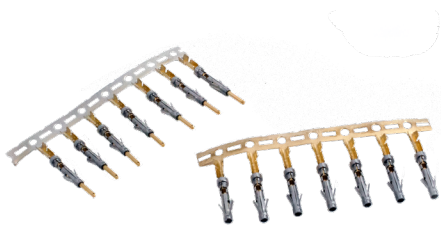

OVERVIEW

Bantam is a lightweight, all-metal bayonet lock connector designed for high volume commercial aerospace applications where electrical performance must be met with affordability. High mating cycles along with excellent shell to shell bonding for EMI protection are the benchmark of these rugged connectors.

Various mounting options are available including in-line and 2 hole flange which can be configured with PC tails. Bantam also offers high density arrangements covering most wire sizes in compact shells to meet your spacing needs. Amphenol has filled the gap between the most ruggedized military grade connectors and consumer grade connectors with Bantam!



APPLICATIONS:

- Cabin & Proximity Lighting
- Sensors
- IFE&C
- In-Seat Wiring
- In-line Connections
- Panel/Equipment Connections

KEY FEATURES & BENEFITS

- Triple bayonet coupling
- Quick, reliable tool-less locking
- Lightweight & Compact
- Excellent EMI shielding
- Variety of platings available
- Five polarization options
- EWIS and RoHS compliant
- Recessed pins minimize potential contact damage
- PCB contacts/arrangements available
- Simplified termination with tape and reel contacts
- Built-in Backshell for wire braid termination (Band-It)



Bantam

Bantam HD

Bantam HD

Micro-Bayonet

	Bantam	Bantam HD
Shell/Coupling Nut	Aluminum Alloy, Various Platings	
EMI Band	Copper Alloy, Nickel Plating	
Retaining Ring	Stainless Steel	
Wave Washer	Stainless Steel	
Rivet	Stainless Steel	
Insert	PA66 (Plastic)	PPS (Plastic)
Grommet, Seal, Gasket	N/A	Silicone Rubber
Contact	Copper Alloy & Stainless Steel, Gold Plating	
Temperature Range	-55°C to 125°C	-65°C to 150°C
Test Voltage	500 VAC	Size 23 500 VAC, Size 12 & 16 1800 VAC
Shell Conductivity	2.5 mΩ max at 1.5 VDC and 1A	
Insulation Resistance	5000MΩ min at 500VDC for 1 min	
Contact Resistance	22mΩ max at 1A	
Mating Cycles	500 cycles	
Vibration	10-500-10 Hz, 180 mins applied on 3 axes	
Thermal Shock	5 cycles between -55°C & 125°C for an elapsed time of 70 mins	5 cycles between -65°C & 150°C for an elapsed time of 70 mins
Salt Spray (Electroless Nickel)	5% Salt Concentration, Duration 48 hrs.	

Shell Dimensions

2 HOLE FLANGE RECEPTACLE

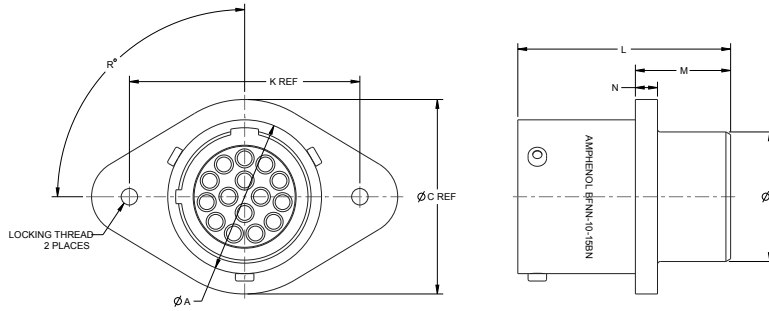

Part Number	Size	Arrangement	Ø A	Ø B	Ø C	K	L	M	N
BFXN-08-07()	08	07	.451-.463	.389-.399	.551	.760	.704-.714	.200-.210	
BFXN-09-10()	09	10	.554-.564	.467-.477	.701	.866	.901-.911	.397-.407	.086-.096
BFXN-10-15()	10	15	.648-.660	.546-.556	.827	.980	.901-.911	.397-.407	

2 HOLE FLANGE RECEPTACLE INTEGRAL BACKSHELL

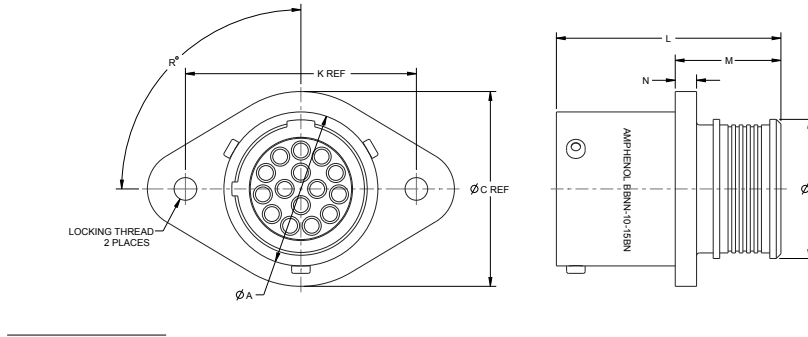

Part Number	Size	Arrangement	Ø A	Ø B	Ø C	K	L	M	N
BBXN-08-07()	08	07	.451-.461	.428-.438	.551	.760			
BBXN-09-10()	09	10	.554-.564	.507-.517	.701	.866	.948-.958	.444-.454	.086-.096
BBXN-10-15()	10	15	.648-.660	.586-.596	.827	.980			

INLINE RECEPTACLE

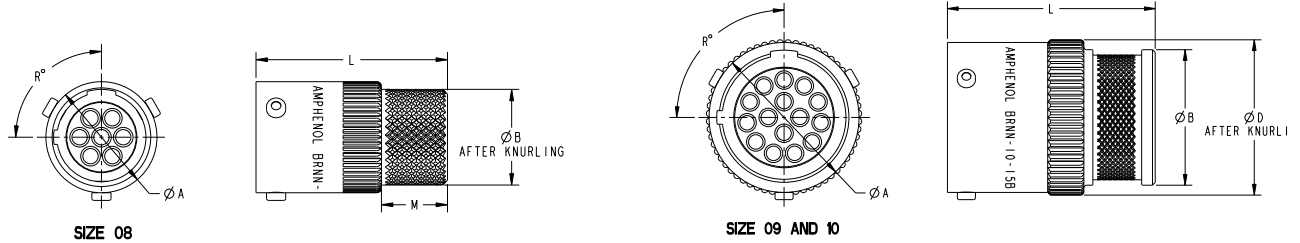

Part Number	Size	Arrangement	Ø A	Ø B	Ø D	L	M
BRXN-08-07()	08	07	.451-.463	.394-.400	N/A	.779-.795	.272-.278
BRXN-09-10()	09	10	.554-.564	.507-.517	.593 Max	.901-.911	N/A
BRXN-10-15()	10	15	.648-.660	.586-.596	.687 Max	.898-.913	N/A

PLUG

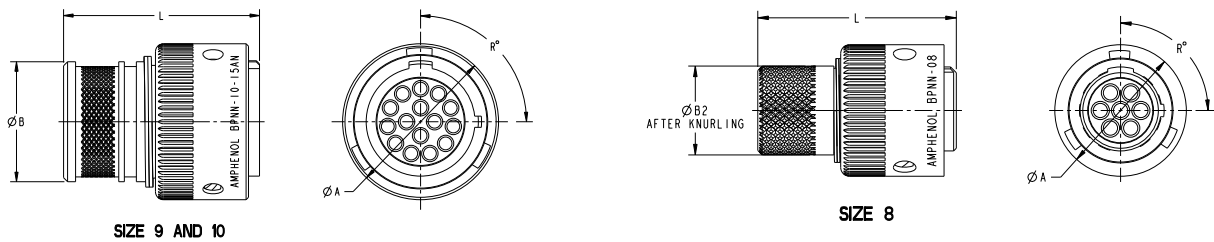

Part Number	Size	Arrangement	Ø A	Ø B	Ø B2	L
BPXN-08-07()	08	07	.583-.591	N/A	.388-.400	.880-.885
BPXN-09-10()	09	10	.677-.685	.507-.517	N/A	.960-.970
BPXN-10-15()	10	15	.768-.776	.586-.596	N/A	.960-.970

How to Order

1.	2.	3.	4.	5.	6.	7.
Series	Shell Plating	Class	Insert Arrangement	Contacts	Keying	Optional Code
BP	N	N-	08-07	P	N	

1. SERIES	
BP	Plug, Integral Backshell
BR	In-Line Receptacle, Integral Backshell
BF	2 Hole Flange Receptacle
BB	2 Hole Flange Receptacle Integral Backshell

2. SHELL PLATING	
N	Electroless Nickel
Z	Gray Zinc Nickel
W	OD CAD
T	Durmalon
B	Black Zinc Nickel
S	Stainless Steel w/ Nickel Plate

3. CLASS	
N-	Non Environmental

4. INSERT ARRANGEMENTS	
Insert Arrg	#22D
08-07	7
09-10	10
10-15	15

5. CONTACTS	
P	Pin Crimp (S&F)
S	Socket Crimp (S&F)
A	Pin, less contacts
B	Socket, less contacts
C	Pin Crimp (machined)
D	Socket Crimp (machined)
E	Pin PC Tail-Length .160
F	Socket PC Tail-Length .160

For Additional information or sizes please contact the factory.

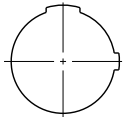
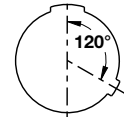
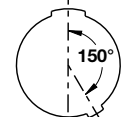
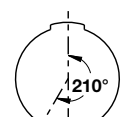
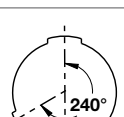
6. KEYING	
N	
A	
B	
C	
D	

7. OPTIONAL CODE	
	Less Accessory
B	Shield Termination Micro Band Included



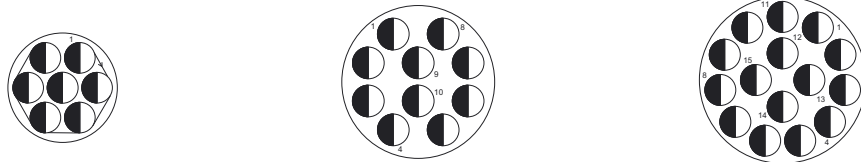

Insert Arrangement	8-7	9-10	10-15
Total Contacts	7	10	15
Contact Size	22D	22D	22D

Size	Current [A]	Contact Type	AWG	Part Number	Crimper	Positioner	Removal Tool
22D	3	Stamped & Formed Pin	22-26	10-712990-721 Individual 10-712991-721X On Reel	10-745003-22D (DMC GMT220)	N/A	10-712998-22D
		Stamped & Formed Socket	22-26	10-712992-721 Individual 10-712993-721X On Reel			
	5	Machined Pin	22-26	10-712994-721	M22520/2-01	DMC K1981	
		Machined Socket	22-26	10-712995-721		DMC K1525	
		PC Tail Machined Pin	PCB Stickout .160"	10-712984-001	N/A	N/A	
		PC Tail Machined Socket	PCB Stickout .160"	10-712985-001			



HD Shell Dimensions

2 HOLE FLANGE RECEPTACLE

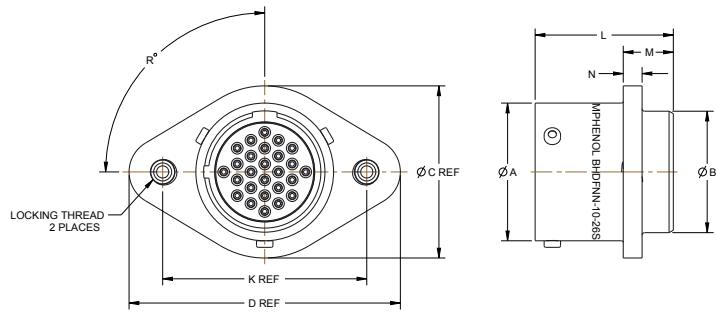

Bantam HD

Part Number	Size	Arrangement	Ø A	Ø B	Ø C	D	K	L	M	N
BHDFXX-10-02()	10	02	.659-.664	.578-.588	.827	1.303	.980	.660-.668	.238-.244	.086-.096
BHDFXX-10-05()	10	05								
BHDFXX-10-06()	10	06								
BHDFXX-10-26()	10	26								

2 HOLE FLANGE RECEPTACLE INTEGRAL BACKSHELL

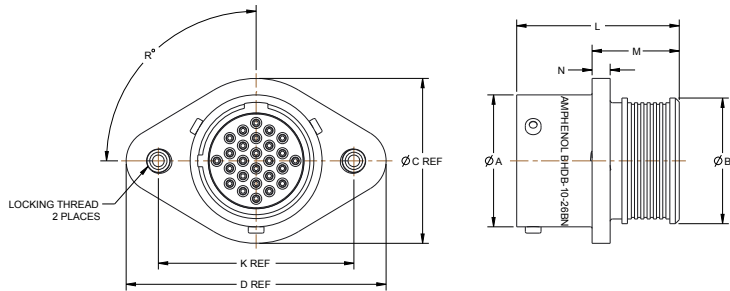

Part Number	Size	Arrangement	Ø A	Ø B	C	D	K	L	M	N
BHDBXX-10-02()	10	02	.659-.664	.625-.634	.827	1.303	.980	.811-.819	.429-.445	.086-.096
BHDBXX-10-05()	10	05								
BHDBXX-10-06()	10	06								
BHDBXX-10-26()	10	26								

INLINE RECEPTACLE

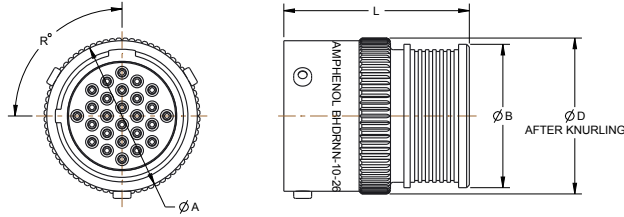

Part Number	Size	Arrangement	Ø A	Ø B	Ø D	L
BHDRXX-10-02()	10	02	.659-.664	.625-.634	.694 Max	.811-.819
BHDRXX-10-05()	10	05				
BHDRXX-10-06()	10	06				
BHDRXX-10-26()	10	26				

Bantam HD

PLUG

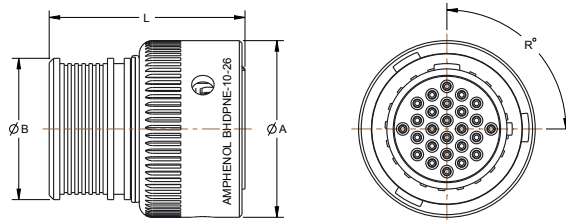

Part Number	Size	Arrangement	Ø A	Ø B	L
BHDPXX-10-02()	10	02	.787-.793	.625-.630	.872-.877
BHDPXX-10-05()	10	05			
BHDPXX-10-06()	10	06			
BHDPXX-10-26()	10	26			

HD Contacts

Bantam HD

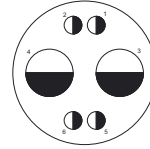
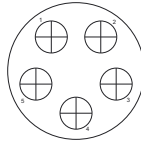

Insert Arrangement	10-02	10-05	10-06	
Total Contacts	2	5	4	2
Contact Size	12	16	23	12

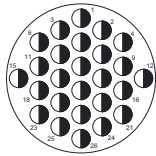

Insert Arrangement	10-26
Total Contacts	26
Contact Size	23

Size	Current [A]	Pin/Socket	AWG	Part Number	Crimper	Positioner	Insertion/ Extraction tool
23	5	Machined Pin	22-28	10-745005-23X	M22520/2-01	DMC K1461-1	M81969/1-05
		Machined Socket		10-745006-23X			
16	13	Machined Pin	16-20	10-745005-16X	M22520/1-01	M22520/1-04	M81969/14-03
		Machined Socket		10-745006-16X			
12	23	Machined Pin	12-14	10-745005-12X	M22520/1-01	M22520/1-04	M81963/14-04
		Machined Socket		10-745006-12X			

1.	2.	3.	4.	5.	6.	7.
Series	Shell Plating	Class	Insert Arrangement	Contacts	Keying	Optional Code
BHDP	N	E-	10-26	P	N	

1. SERIES	
BHDP	Plug, Integral Backshell
BHDR	In-Line Receptacle, Integral Backshell
BHDF	2 Hole Flange Receptacle
BHDB	2 Hole Flange Receptacle Integral Backshell

2. SHELL PLATING	
N	Electroless Nickel
W	OD Cad
Z	Grey Zinc Nickel

3. CLASS	
E-	Environmental
N-	Non Environmental

4. INSERT ARRANGEMENTS			
Insert Arrg	#23	#16	#12
10-02			2
10-05		5	
10-06	4		2
10-26	26		

5. CONTACTS	
P	Pin Crimp
S	Socket Crimp
A	Pin, less contacts
B	Socket, less contacts
E	Pin PC Tail
F	Socket PC Tail

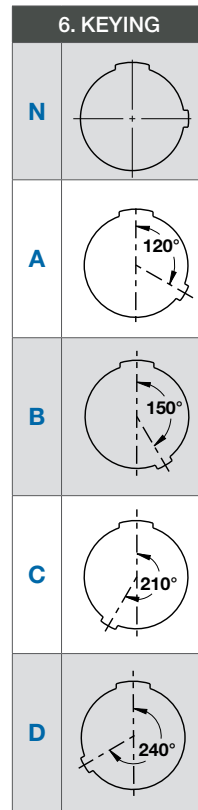

7. OPTIONAL CODE	
	Less Accessory
B	Shield Termination Micro Band Included

For additional information or sizes please contact the factory



Bantam HD

Tools

Bantam



Part Number	Description
10-745003-22D (DMC GMT220)	Stamped and Formed Contact Crimp Tool



Part Number	Description
M22520/2-01	Machined Crimp Contact Tool
M22520/1-01	Machined Crimp Contact Tool

Bantam HD



Part Number	Description
DMC DBS-2200	Shield Termination Band Tool



Part Number	Description
DMC K1461-1	Positioner
M22520/1-04	Positioner
DMC K1981	Positioner
DMC K1525	Positioner



Part Number	Description
10-712998-22D	Extraction Tool



Part Number	Description
M81969/1-05	Insertion/ Extraction Tool
M81969/14-03	Insertion/ Extraction Tool
M81969/14-04	Insertion/ Extraction Tool

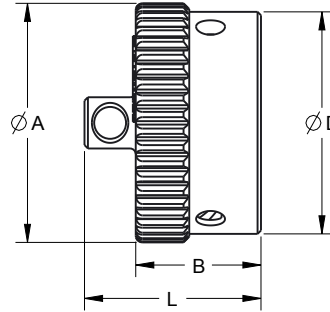
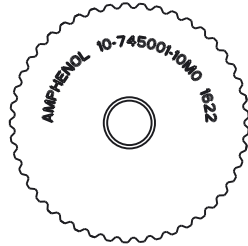

Part Number	Cap Size	Material	ØA	B	ØD	L
10-745001-08M	08	Aluminum Alloy	.622-.638	.425-.441	.563-.579	.602-.618
10-745001-09M	09		.724-.740		.665-.681	
10-745001-10M	10		.819-.835		.760-.776	

For additional information on Bantam HD Flyaway Caps contact the factory

SHIELD TERMINATION BAND 10-712996-000

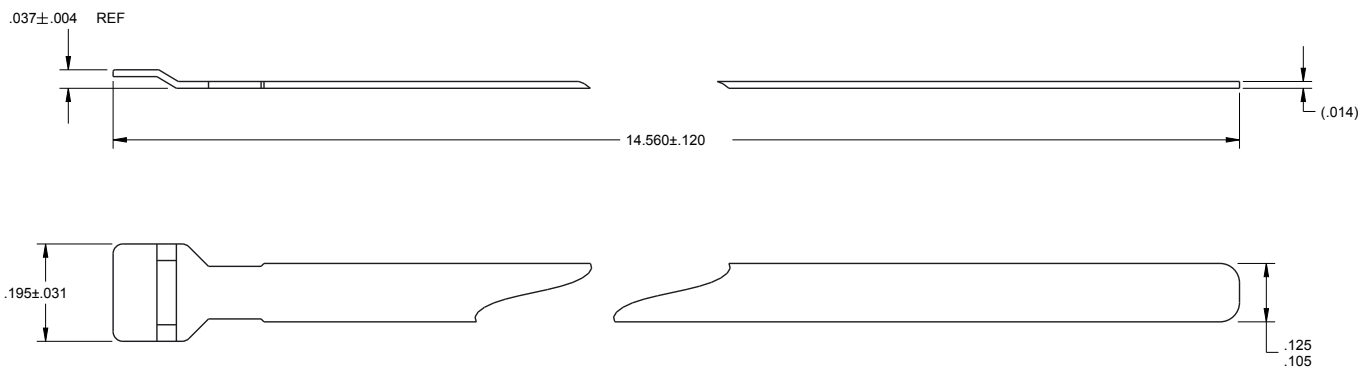

Bantam

Bantam HD

Stamped and Formed Contact Crimp Instructions

WIRE PREPARATION

Strip wire to length shown in chart. DO not cut or nick wire strands. Twist wire strands back to form a firm bundle.

CONTACT AND WIRE SIZES			
Contact Size	Wire Size	Insulation O.D.	Stripping Length "A"
22D	22-28 AWG	.030-.055 in	.118-.157 in



CRIMP TOOL

Part Number: 10-745003-22D or DMC GMT220



CRIMP WIRE TO CONTACTS

1. Put the wire into the contact. All wire strands should be in crimp barrel. Place contact crimp barrel on correct anvil of tool with open side facing up.
2. Slowly close jaws until the contact is retained by crimping jaws
3. Check that the wire is in place, making sure all wire strands are in crimp barrel. Continue to close the jaws slowly, until the ratchet disengages.
4. The tool will not release until the crimp cycle is complete.

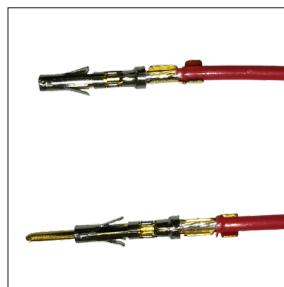

Step One



Step Two



Step Three

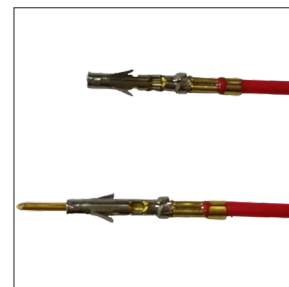

Step Four

Contact Wires and Sizes			
Contact Size	Wire Size	Insulation O.D.	Stripping Length "A"
23	22-28 AWG	.025-.048 in	.115 in
16	16-20 AWG	.065-.109 in	.188 in
12	12-14 AWG	.097-.142 in	.188 in

For wire preparations see instructions on page 14.

CRIMP TOOL SETUP

1. Select proper crimp tool and positioner based on contact size from the tables on page 7 or 10.
2. Assemble positioner on crimp tool and turn to lock it in place.
3. Use instructions on the positioner to set the dial on the crimp tool.

CRIMP WIRE TO CONTACTS

1. Place the wire into the contact. All wire strands should be in crimp barrel and wire must be visible through inspection hole.
2. Place the contact fully into the crimp tool so the contact shoulder is against the crimp tool shoulder.
3. Squeeze the handles on the crimp tool together firmly until the ratchet disengages. The tool will not release until the crimp cycle is complete.
4. Check that the wire is still visible through the inspection hole in the contact.

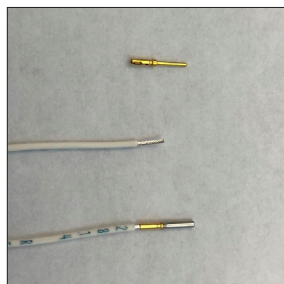

Step One

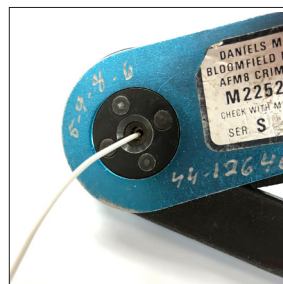

Step Two

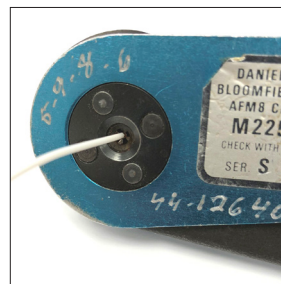

Step Three

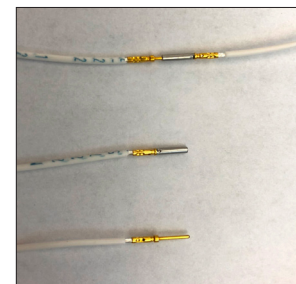

Step Four

Notice: Specifications are subject to change without notice. Contact your nearest Amphenol Corporation Sales Office for the latest specifications. All statements, information and data given herein are believed to be accurate and reliable but are presented without guarantee, warranty, or responsibility of any kind expressed or implied. Statements or suggestions concerning possible use of our products are made without representation or warranty that any such use is free of patent infringement and are not recommendations to infringe any patent. The user should not assume that all safety measures are indicated or that other measures may not be required. Specifications are typical and may not apply to all connectors.

© 2018 Amphenol Corp.

Printed in U.S.A. 9-2018

AMPHENOL CORPORATION

40-60 Delaware Avenue, Sidney, NY 13838-1395 • 800-678-0141
www.amphenol-aerospace.com • www.amphenolmao.com