

CTF-10G-4-SM

PDS - 263-1

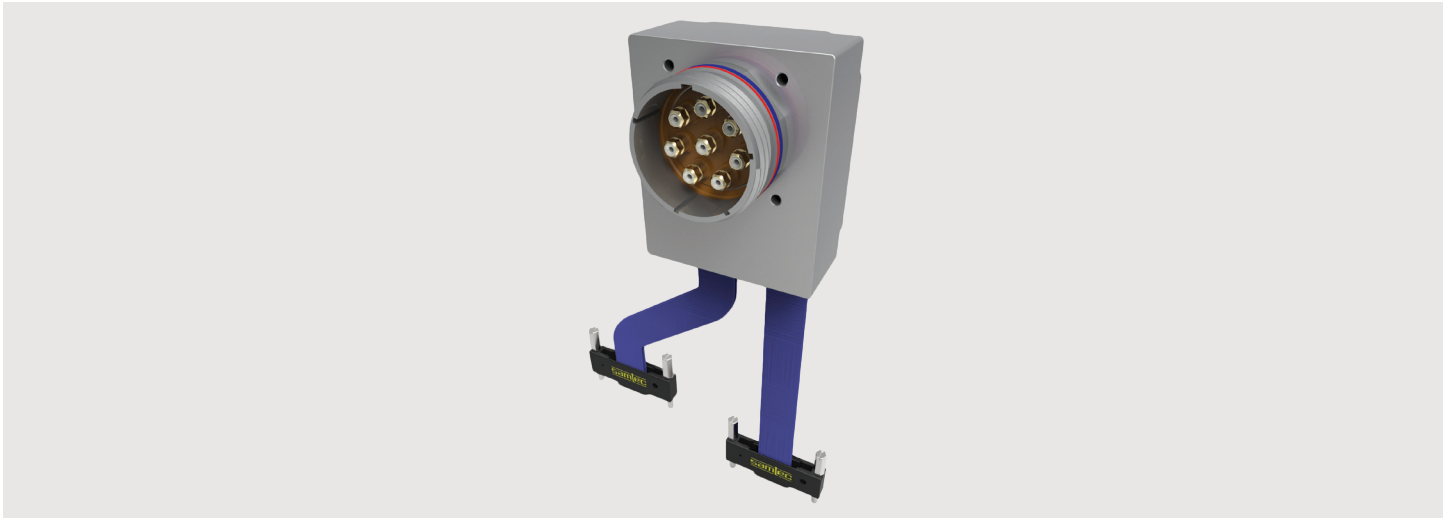

Amphenol Aerospace adds the CTF-10G-4-SM fiber to copper converter to the Integrated Electronics Product Line. This product line is rugged, flexible, and affordable with many options available.

The converter is an integrated media converter and SERDES interfacing with both four channels of XAUI and four channels of single mode bi-directional 10G Ethernet.

FEATURES:

- 4 channels (4 Tx, 4 Rx) 10GbE on Single Mode Fiber Converted Bi-Directionally to 4 Channels of XAUI
- D38999 Shell Size 25

RUGGEDIZATION:

- Natural Convection Cooled (no fan)
- Operational Temperature -40°C to +85°C
- Storage Temperature -40°C to +125°C
- EMI/EMC Compatible
- Refer to Page 4 for Additional Details

FIBER INTERFACE:

- D38999 Shell Size 25 Receptacle with CTF-QUAD Single Mode 1310nm Fiber
- 4 Tx and 4 Rx 1310nm Single Mode Fiber Embedded into Size 8 Contacts with 1.25mm Industry Standard Ceramic Interface

COPPER INTERFACE:

- Samtec Q Series High Speed Cable Assembly and Vertical Mount Board Connectors
- Two Hanging Cable Assemblies for Distributed Connections Across the Subsystem, and Backplane
- Low Power Consumption
- MDIO Serial Interface for Built-In Test and Diagnostics

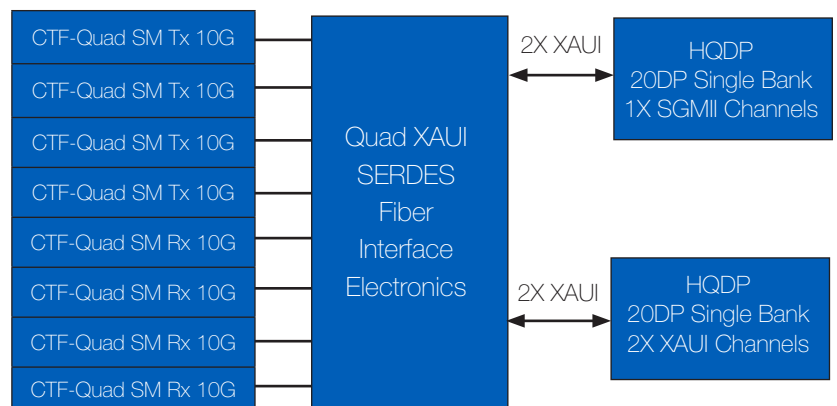

CTF-10G-4-SM DRAWING

1.	2.	3.	4.	5.
Part Number Suffix	Cable 1 Length (inches)	Cable 3 Length (inches)	Shell Rotation	Clocking
CF-1200	01	01	N	W

STEP 1 :

Choose a Part Number Suffix

Connector Type
CF-1200

STEP 2 :

Choose Cable 1 Length

Cable 1 Length (Inches)
01-99

STEP 3 :

Choose Cable 2 Length

Cable 2 Length (Inches)
01-99

Other finishes available please consult Amphenol Aerospace's factory. Customer defined Samtec lengths

STEP 4 :

Choose a Shell Rotation

Shell Rotation
N
A
B
C
D
E

STEP 5 :

Choose a Clocking

Clocking
W
X
Y
Z

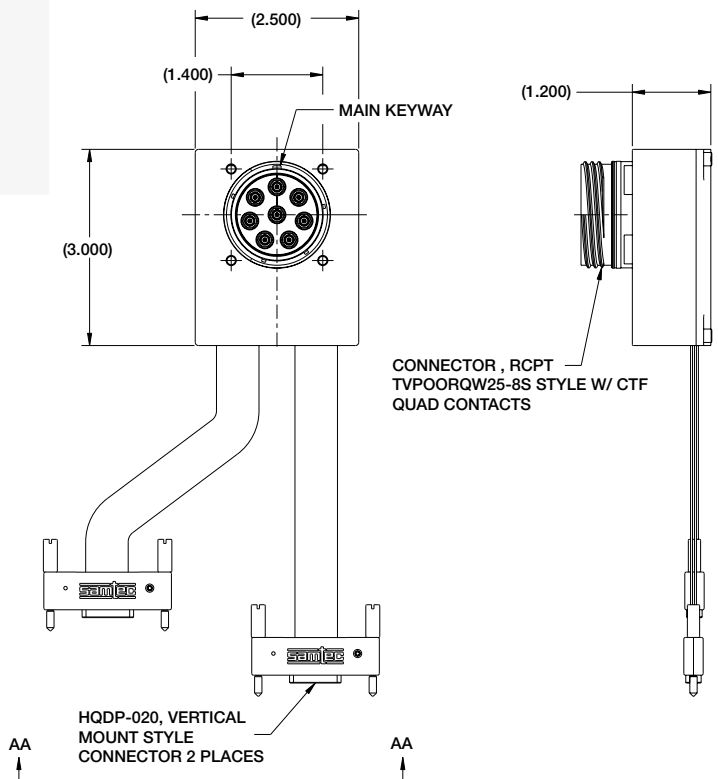
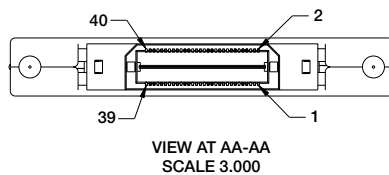

CTF-10G-4-SM

Samtec HQDP-020 (20 pairs; 40 signals) ¹			
Pin	Description	Pin	Description
1	CH1 XAUI 1 Tx+	2	CH2 XAUI 1 Tx+
3	CH1 XAUI 1 Tx-	4	CH2 XAUI 1 Tx-
5	CH1 XAUI 1 Rx+	6	CH2 XAUI 1 Rx+
7	CH1 XAUI 1 Rx-	8	CH2 XAUI 1 Rx-
9	CH1 XAUI 2 Tx+	10	CH2 XAUI 2 Tx+
11	CH1 XAUI 2 Tx-	12	CH2 XAUI 2 Tx-
13	CH1 XAUI 2 Rx+	14	CH2 XAUI 2 Rx+
15	CH1 XAUI 2 Rx-	16	CH2 XAUI 2 Rx-
17	CH1 XAUI 3 Tx+	18	CH2 XAUI 3 Tx+
19	CH1 XAUI 3 Tx-	20	CH2 XAUI 3 Tx-
21	CH1 XAUI 3 Rx+	22	CH2 XAUI 3 Rx+
23	CH1 XAUI 3 Rx-	24	CH2 XAUI 3 Rx-
25	CH1 XAUI 4 Tx+	26	CH2 XAUI 4 Tx+
27	CH1 XAUI 4 Tx-	28	CH2 XAUI 4 Tx-
29	CH1 XAUI 4 Rx+	30	CH2 XAUI 4 Rx+
31	CH1 XAUI 4 Rx-	32	CH2 XAUI 4 Rx-
33	5V Power	34	5V Power
35	Ground	36	Ground
37	MDIO	38	MDC
39	LOS	40	Transmit Disable
Ribbon Connector - QTH-020-01-H-D-DP-EM2			
Board Connector - QSH-020-01-H-D-DP-K			
Board Connector must be used with SO-0165-0401-02 Screw Mounts with correct spacing			

Samtec HQDP-020 (20 pairs; 40 signals) ¹			
Pin	Description	Pin	Description
1	CH3 XAUI 1 Tx+	2	CH4 XAUI 1 Tx+
3	CH3 XAUI 1 Tx-	4	CH4 XAUI 1 Tx-
5	CH3 XAUI 1 Rx+	6	CH4 XAUI 1 Rx+
7	CH3 XAUI 1 Rx-	8	CH4 XAUI 1 Rx-
9	CH3 XAUI 2 Tx+	10	CH4 XAUI 2 Tx+
11	CH3 XAUI 2 Tx-	12	CH4 XAUI 2 Tx-
13	CH3 XAUI 2 Rx+	14	CH4 XAUI 2 Rx+
15	CH3 XAUI 2 Rx-	16	CH4 XAUI 2 Rx-
17	CH3 XAUI 3 Tx+	18	CH4 XAUI 3 Tx+
19	CH3 XAUI 3 Tx-	20	CH4 XAUI 3 Tx-
21	CH3 XAUI 3 Rx+	22	CH4 XAUI 3 Rx+
23	CH3 XAUI 3 Rx-	24	CH4 XAUI 3 Rx-
25	CH3 XAUI 4 Tx+	26	CH4 XAUI 4 Tx+
27	CH3 XAUI 4 Tx-	28	CH4 XAUI 4 Tx-
29	CH3 XAUI 4 Rx+	30	CH4 XAUI 4 Rx+
31	CH3 XAUI 4 Rx-	32	CH4 XAUI 4 Rx-
33	5V Power	34	5V Power
35	Ground	36	Ground
37	MDIO	38	MDC
39	LOS	40	Transmit Disable
Ribbon Connector - QTH-020-01-H-D-DP-EM2			
Board Connector - QSH-020-01-H-D-DP-K			
Board Connector must be used with SO-0165-0401-02 Screw Mounts with correct spacing			

MIL-DTL-38999 SHell Size 25 with CTF-QUAD			
A	CH1 Tx	E	CH3 Tx
B	CH1 Rx	F	CH3 Rx
C	CH2 Tx	G	CH4 Tx
D	CH2 Rx	H	CH4 Rx

AMPHENOL INTEGRATED ELECTRONIC PRODUCTS RUGGEDIZATION DESIGN

OVERVIEW

Amphenol integrated electronic products are designed and manufactured to our Ruggedization guidelines listed below. These guidelines ensure years of reliable operation in harsh environment applications where extreme operating temperatures, shock, vibration and corrosive atmospheres are regularly experienced.

TEMPERATURE:

- Operating Temperature- Thermal Cycles between -40°C and 85°C while device is operating
- Temperature is measured at chassis housing or card edge
- Storage Temperature- Thermal Cycles between -55°C and 125°C

HUMIDITY:

- Operating Humidity- Humidity cycle between 0-100% non-condensing humidity while device operating
- Storage Humidity- Humidity cycle between 0-100% condensing humidity

SEALING:

- Sealing can be optionally provided at the MIL-DTL-38999 interface with up to 10-5 cc/sec performance

FLUIDS SUSEPTIBILITY:

- MIL-DTL-38999 receptacle interface per EIA-364-10E

VIBRATION & SHOCK:

- Sine Vibration - 10g Peak, 5-2,000Hz
Based on a sine sweep duration of 10 minutes per axis in each of three mutually perpendicular axes. May be displacement limited from 5 to 44 Hz, depending on specific test.
- Random Vibration - 0.0005 @ 5Hz, 0.1 @ 15 Hz, 0.1 @ 2,000 Hz
60 minutes per axis, in each of three mutually perpendicular axes.
- 40 G Peak Shock Cycle
Three hits in each axis, both directions, ½ sine and terminal-peak saw tooth, Total 36 hits.

ALTITUDE:

- -1,500 to 60,000 ft Altitude Testing w/ Rapid Depressurization

ELECTROMAGNETIC COMPATIBILITY:

- Designed to comply with MIL-STD-461E

PRINTED CIRCUIT BOARD ASSEMBLIES:

- Conformal Coat
Amphenol performs Conformal Coating to both sides of printed circuit board assemblies using HUSMISEAL IB31 in accordance with IPC-610, Class 3.
- Printed Circuit Board Rigidity
Amphenol printed circuit boards are fabricated in accordance with IPC-6012, Class 3.
- Printed Circuit Board Fabrication
Amphenol printed circuit boards acceptance criteria is in accordance with IPC-610, Class 3.

RELIABILITY PREDICTIONS (MTBF):

Amphenol can perform Mean Time Between Failure (MTBF) reliability analysis in full compliance with MIL-HDBK-217F-1 Parts Count Prediction and MIL-HDBK-217F-1 Parts Stress Analysis Prediction. We can also perform reliability analyses in full compliance of ANSI/VITA 51.1 if it is required or preferred over the later method.

Notice: Specifications are subject to change without notice. Contact your nearest Amphenol Corporation Sales Office for the latest specifications. All statements, information and data given herein are believed to be accurate and reliable but are presented without guarantee, warranty, or responsibility of any kind, expressed or implied. Statements or suggestions concerning possible use of our products are made without representation or warranty that any such use is free of patent infringement and are not recommendations to infringe any patent. The user should assume that all safety measures are indicated or that other measures may not be required. Specifications are typical and may not apply to all connectors.

AMPHENOL is a registered trademark of Amphenol Corporation. ©2021 Amphenol Corporation REV:6/3/2021