

LIGHTCONEX™

BANDWIDTH UNLEASHED AND VITA 66.5 QUALIFIED



DESCRIPTION

Amphenol Aerospace introduces LightConex™ blind mate optical interconnect for VPX embedded computers. LightConex™ integrates a 40Gbps optical transceiver, 120G optical transmitter, and 120G optical receiver into the module connector saving board space and eliminating cables.

The low profile backplane connector qualified to VITA 66.5. It includes springs to ensure a solid MT to MT connection under extreme shock and vibration.

The low profile module connector (6.5mm) mounts to the board via an LGA

connector to facilitate optics as an option. It is offered as a 4-channel transceiver, a 12 channel transmitter or a 12-channel receiver. All module connectors operate at up to 12.5 Gbps per lane from -40 to +85°C at ultra-low bit error rates of 10⁻¹⁵. The module connector also includes equalizers and pre-emphasis to compensate trace impedance.

Module Connector Features:

- **Rugged:** MIL STD 883
- **Moisture resistant:** Sealed
- **Small (DxWxH):** 14 x 23 x 6 mm
- **Bandwidth:** 10.3125 Gbps/ch
- **Temperature:** -40°C to +85°C
- **Reach:** 300m, multi-mode
- **BER:** 10⁻¹⁵
- **Low power:** 1.2W
- **Data interface:** CML
- **Board Mount:** LGA
- **Configurations:**
4TRx, 12Tx, 12Rx, 12TRx

Backplane Connector Features:

- Vita66.4 drop in replacement
- Spring loaded MT
- Coarse and fine alignment
- Low Profile - 10mm

Applications:

- VPX Single Board Computers
- Phased Array Radars
- Single processing computer

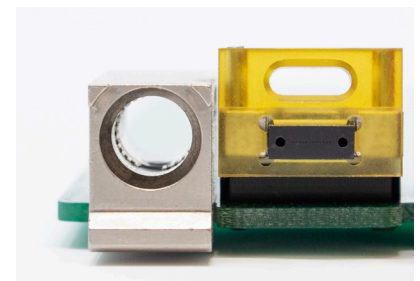

QUALIFICATION TESTS

Vibration

- Sine Vibration Sweep - 10 minute sine vibration sweep of 5 g between 50 and 2000 Hz
- Shock - MIL-STD-1344A, Method 2004.1, Test Condition A (1/2 sine, 50 g in perpendicular axis, 80 g in other axes, 11 ms, 3 hits from both directions in each of 3 mutually perpendicular axes for a total of 18 hits)
- Random Vibration
 - Sample 1 - Test Condition V, letter D (0.1 G²/Hz max., 1.5 hours per axis)
 - Sample 2 - Step stress 0.125 G²/Hz for 15 minutes, 0.15 G²/Hz for 15 minutes, 0.175 G²/Hz for 15 minutes, and 0.2 G²/Hz for 45 minutes

Bench Handling

- The sample under test was raised on one edge using the opposite edge as a hinge 4 inches or 45 degrees (whichever is less). The other edges were tested the same.

Vibration over Temperature

- MIL-STD-1344A, Method 2005.1, Test Condition V, Letter D (0.1 G²/Hz max., 1.5 hours per axis, see Fig. 2 solid line), with simultaneous temperature exposure of -40 to 85°C.

Humidity

- Expose to humidity and temperature cycling per MIL-STD-1344A, Method 1002.2, Type III (240 hrs.). The sample shall be mated.

Salt Fog

- Salt Fog with SO₂ per ASTM G85 (Annex A4, Cycle A4.4.4.1). The test sample shall be exposed in the mated condition in a sheet metal container.

Sand and Dust

- MIL-STD-810F, Method 510.4, Procedure I (Blowing Dust, particle size < 150 µm, velocity 1750 ft/min). The sample will be mated. The dust test on these two samples will be followed by a Blowing Sand test, also per MIL-STD-810F, Method 510.4, Procedure II (Blowing Sand, particle size > 150 µm but < 850 µm, velocity 5700 ft/min).

Durability

- 500 mate/un-mate cycles. VI, RNT shall be performed after 500 mate/un-mate cycles.

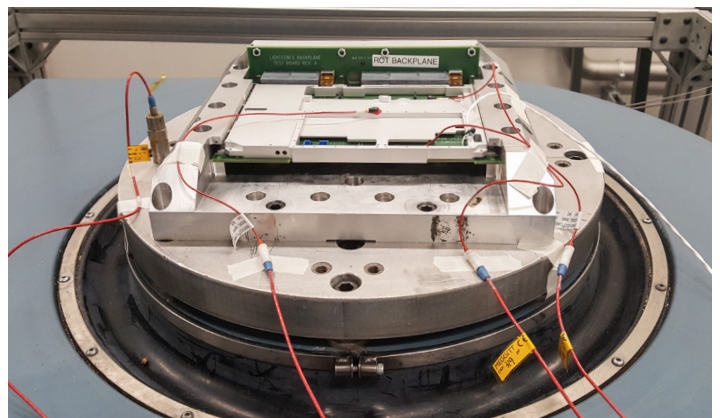
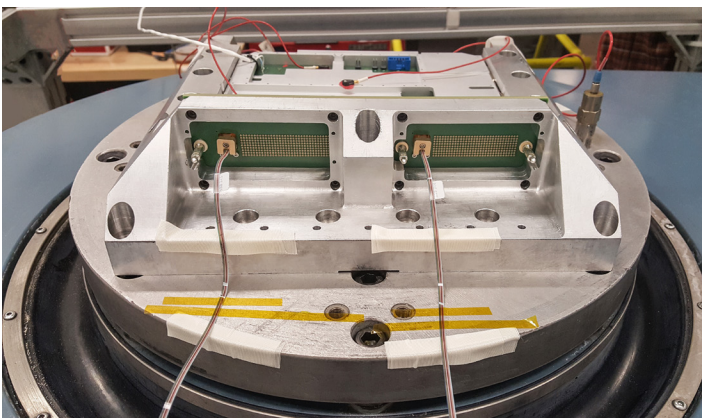

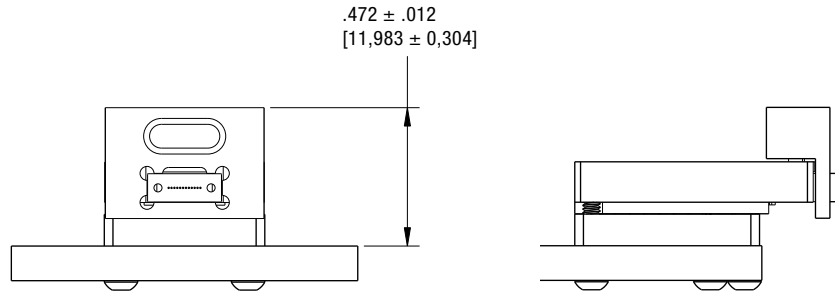

Part Number	Reflex Optical Active Device P/N (POS 5)	Reflex Optical Active Device Description
10-743008-003*	NONE	NONE
10-743008-004	10-743017-004	4TX/4RX, Transceiver, 10.3125-Gbps/CH, SENS: -12.0dBm**, -40°C to +85°C
10-743008-005	10-743017-005	12TX, Transmitter, 10.3125-Gbps/CH, -40°C to +85°C
10-743008-006	10-743017-006	12RX, Receiver, 10.3125-Gbps/CH, SENS: -12.0dBm**, -40°C to +85°C

* 10-743008-003 includes all the components to connect an optical device to a PCB without the optical device itself.

** If operating at 12.5 Gbps the receiver sensitivity will be -4dBm

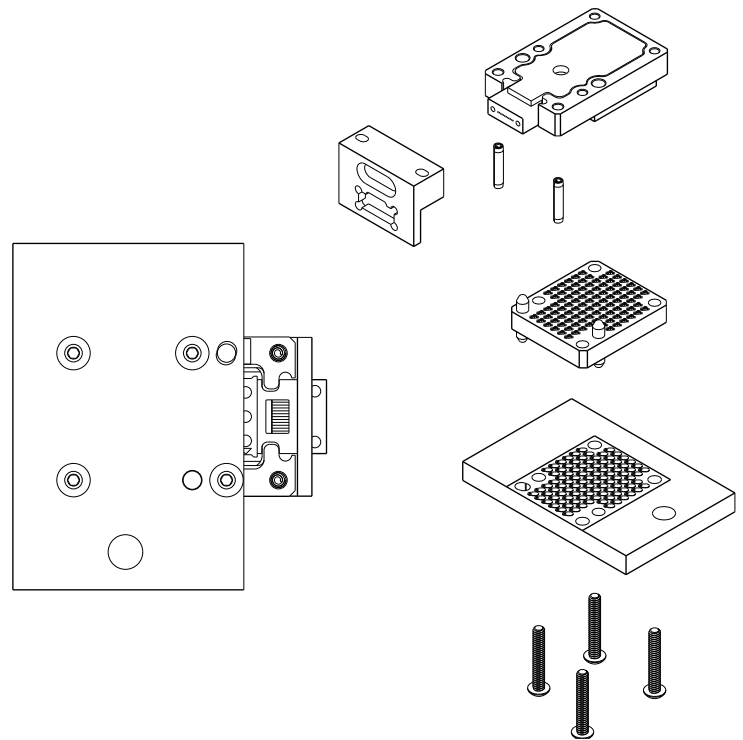
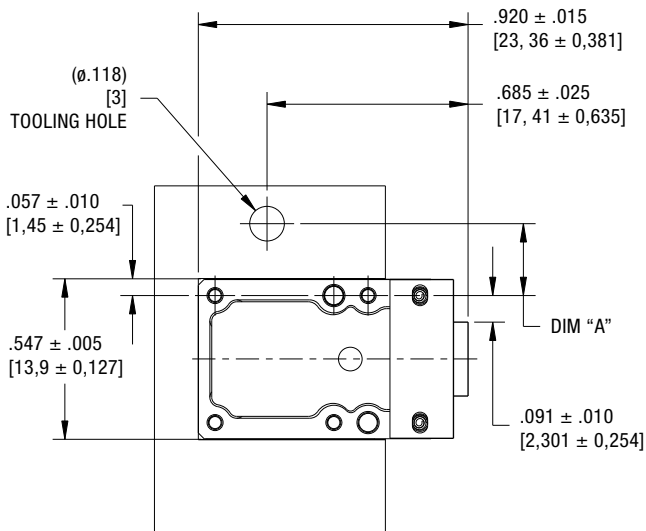

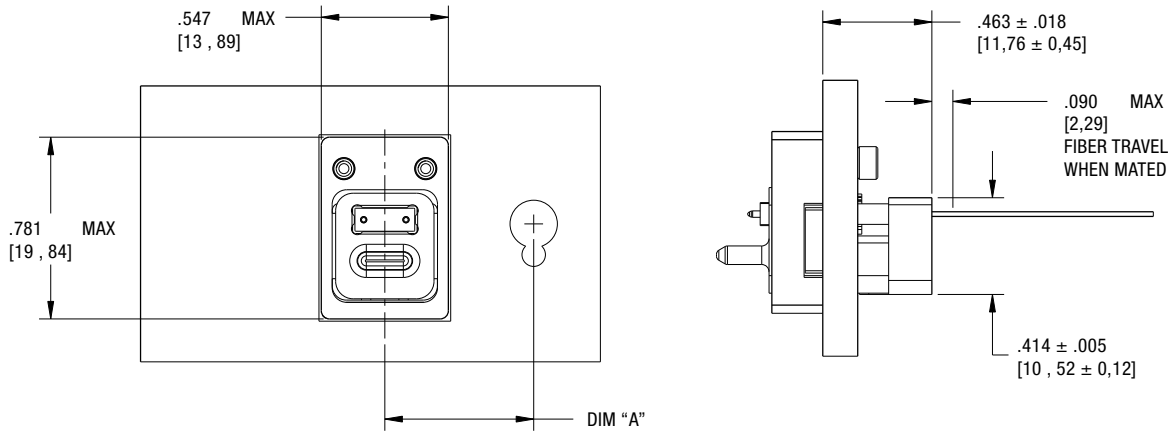

Part Number	Optical Active Device Description
10-743007-002	Passive Backplane Connector

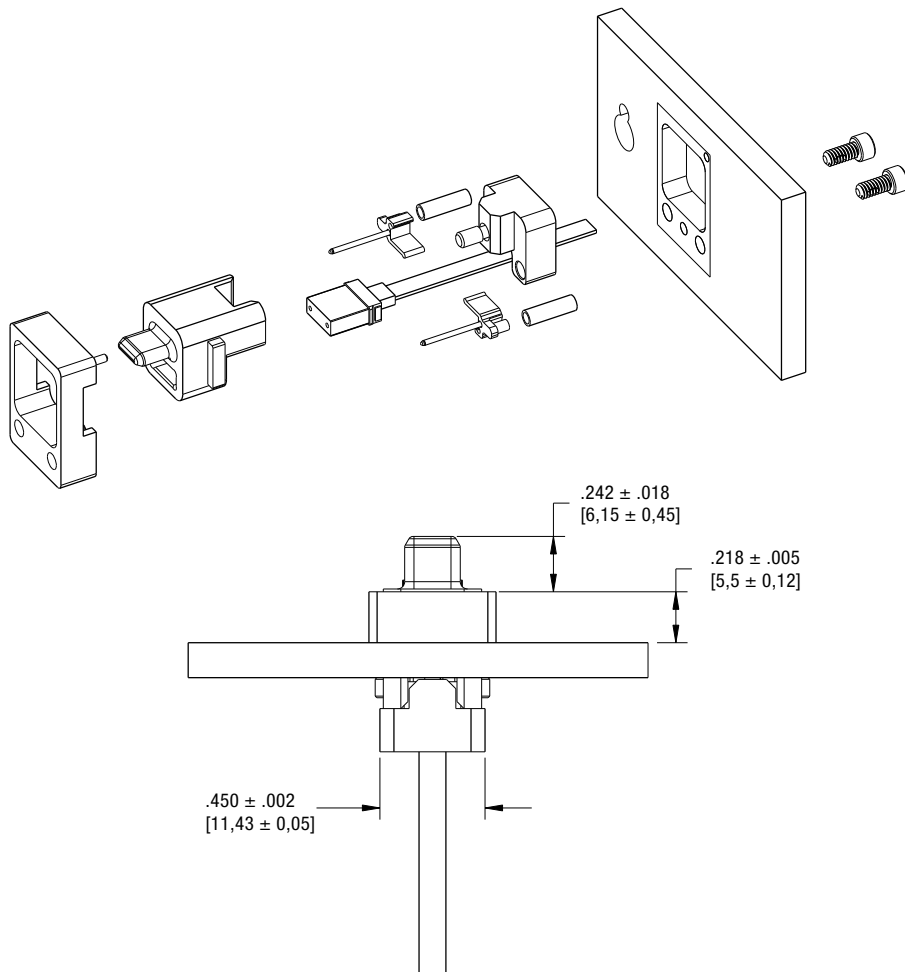

4TX/RX
10-743008-004

	1	2	3	4	5	6	7	8	9	10	
A			VCC	GND	GND	GND	VCC	VCC			A
B			SDA	GND	SCL	SS	VCC	VCC			B
C			GND	GND	LDIS	NINT	GND	GND			C
D			DNC	DNC	GND	GND	DNC	DNC			D
E	ND04	D04	GND	GND	GND	DNC	GND	GND	DI4	NDI4	E
F	VCC	VCC	GND	GND	C2D	C2DCK	GND	GND	VCC	GND	F
G	DNC	DNC	GND	GND	VCC	VCC	VCC	GND	DNC	DNC	G
H	GND	GND	GND	GND	VCC	VCC	GND	GND	GND	GND	H
I	D01	GND	D02	GND	VCC	VCC	GND	DI2	GND	DI1	I
J	ND01	GND	ND02	GND	GND	GND	GND	NDI2	GND	NDI1	J
K			GND	GND	GND	GND	GND	GND			K
L			ND03	D03	GND	GND	NDI3	DI3			L
	1	2	3	4	5	6	7	8	9	10	

12TX
10-743008-005

	1	2	3	4	5	6	7	8	9	10	
A			VCC	GND	GND	GND	VCC	VCC			A
B			SDA	GND	SCL	SS	VCC	VCC			B
C			GND	GND	LDIS	NINT	GND	GND			C
D			NDI6	DI6	GND	GND	NDI7	DI7			D
E	NDI5	DI5	GND	GND	GND	DNC	GND	GND	NDI8	DI8	E
F	VCC	VCC	GND	GND	C2D	C2DCK	GND	GND	VCC	GND	F
G	NDI4	DI4	GND	GND	VCC	VCC	VCC	GND	NDI9	DI9	G
H	GND	GND	GND	GND	VCC	VCC	GND	GND	GND	GND	H
I	DI1	GND	DI2	GND	VCC	VCC	GND	NDI11	GND	NDI12	I
J	NDI1	GND	NDI2	GND	GND	GND	GND	DI11	GND	DI12	J
K			GND	GND	GND	GND	GND	GND			K
L			NDI3	DI3	GND	GND	NDI10	DI10			L
	1	2	3	4	5	6	7	8	9	10	

12RX
10-743008-006

	1	2	3	4	5	6	7	8	9	10	
A			VCC	GND	GND	GND	VCC	VCC			A
B			SDA	GND	SCL	SS	VCC	VCC			B
C			GND	GND	DNC	NINT	GND	GND			C
D			ND06	D06	GND	GND	ND07	D07			D
E	ND05	D05	GND	GND	GND	DNC	GND	GND	ND08	D08	E
F	VCC	VCC	GND	GND	C2D	C2DCK	GND	GND	VCC	GND	F
G	ND04	D04	GND	GND	VCC	VCC	VCC	GND	ND09	D09	G
H	GND	GND	GND	GND	VCC	VCC	GND	GND	GND	GND	H
I	D01	GND	D02	GND	VCC	VCC	GND	ND011	GND	ND012	I
J	ND01	GND	ND02	GND	GND	GND	GND	D011	GND	D012	J
K			GND	GND	GND	GND	GND	GND			K
L			ND03	D03	GND	GND	ND010	D010			L
	1	2	3	4	5	6	7	8	9	10	