

Bendix® Commercial Aircraft Cylindrical Connectors

12-101-3

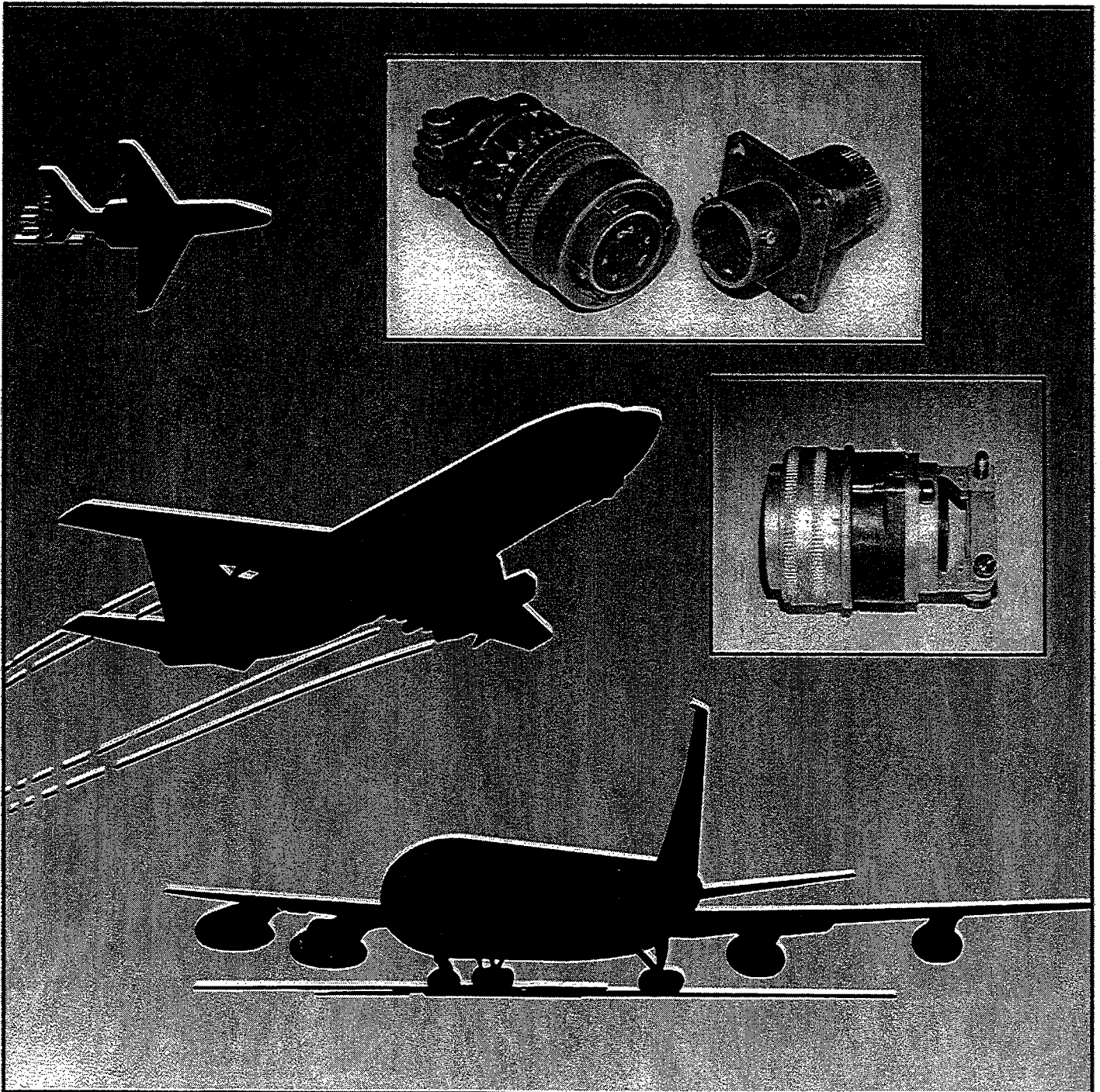

Amphenol

Bendix® Commercial Aircraft Cylindrical Connectors

Bendix Commercial Aircraft Connectors consist of the DC Series which is a MIL-C-26482, front release crimp design using metal retention clips, and the 10-244 Series which is a MIL-C-5015 proprietary crimp design. Materials and finishes have been selected for improved temperature capability and for resistance to fluids associated with aircraft industry environments.

Also included in this publication is the BT high temperature aircraft connector which has ceramic inserts. See page 21 for a brief description and consult Amphenol, Bendix Connector Operations, Sidney, NY for further information on this aircraft cylindrical connector series. Other commercial aircraft specials and related connector products are shown on page 22.

TABLE OF CONTENTS

	Page No.
Bendix® DC Series Connectors	
(Operating temperature up to 300° F)	
DC, General Description, How to Order	2
DC, Specifications and Insert Availability, Identification, Alternate Positions	3
DC, Insert Arrangements	4
DC20, Wall Mounting Receptacle	5
DC21, Cable Connecting Plug	6
DC24, Jam Nut Receptacle	7
DC26, Straight Plug	8
DC, Application Tools	9
Bendix® 10-244 Series Connectors	
(Operating temperature up to 400° F)	
DC, General Description, How to Order	10
10-244, Specifications	11
10-244, Insert Availability, Identification, Alternate Positions	12
10-244, Insert Arrangements	13, 14
10-2440, Wall Mounting Receptacle	15
10-2442, Box Mounting Receptacle	16
10-2446, Straight Plug	17
10-2448, 90° Plug (closed)	18
10-2484, 90° Plug (open)	19
10-244, Application Tools	20
Other Commercial Aircraft Connectors	
BT, High Temperature Connectors with ceramic inserts	21
Commercial Aircraft Specials	22

Sales Office Listing

Bendix® DC Series Connectors

fluid resistant, resilient inserts

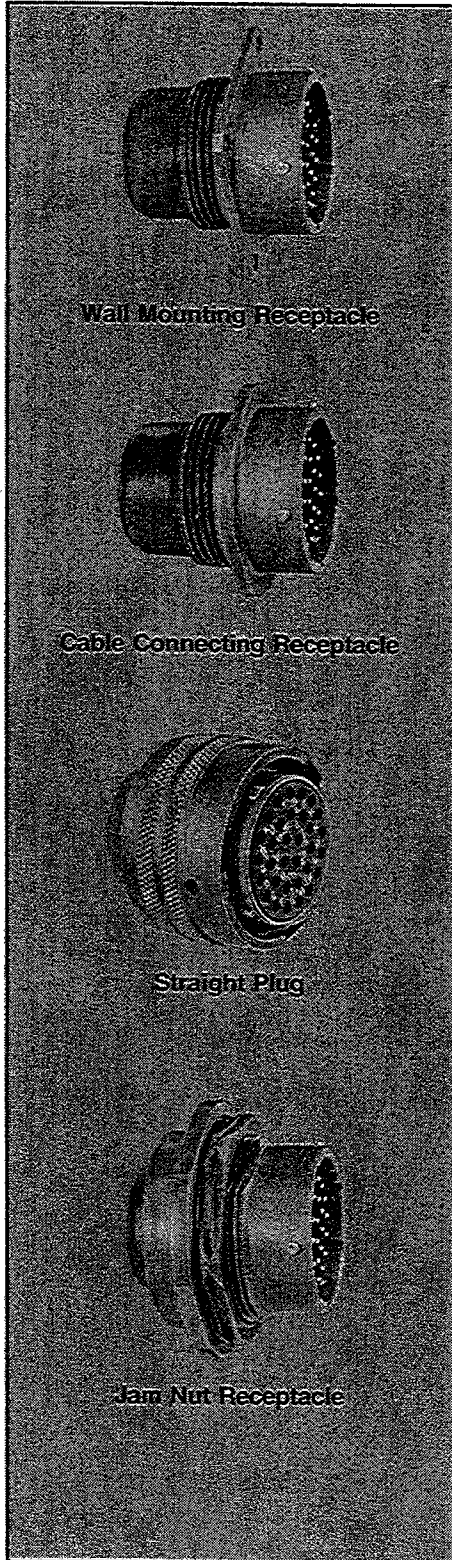

Wall Mounting Receptacle

Cable Connecting Receptacle

Straight Plug

Jam Nut Receptacle

The Bendix® DC connector series is approved for DC-8, DC-9, and DC-10 aircraft applications. This family of electrical connectors is designed to meet the applicable requirements of MIL-C-26482 and provides complete mating interchangeability with 3 point bayonet coupling connectors covered by MIL-C-26482. Contacts are crimp type in accordance with MIL-C-39029/31 and 32.

Components

- Shells and coupling nuts are made from high grade aluminum alloy and are cadmium plated to QQ-P-416 with olive drab chromate after treatment.
- Contacts are machined from high grade copper alloy and are gold plated.
- Resilient inserts, main joint gaskets, and strain relief glands are molded from EPT (Ethylene Propylene Terpolymer) material which exhibits the following characteristics:
 - excellent electrical properties.
 - operating temperature range from -65° to $+300^{\circ}$ F.
 - resistance to Ozone and Corona.
 - resistance to Skydrol and other synthetic oils, Hydrazine, and Oxydizing acids.
- Resilient O-ring on DC 24 jam nut is molded from a butyl material that exhibits characteristics which are similar to EPT.

How to Order

To more easily illustrate ordering procedure, part number DC26F-10-6PW(SR) less contacts is shown as follows:

DC	26	F	-	10	-	6	P	W	(SR)	<u>less contacts</u>
1	2	3		4		5	6	7	8	9

1. Connector type
2. Shell style
 - 20 designates wall mount receptacle
 - 21 designates cable connecting plug
 - 24 designates jam nut receptacle
 - 26 designates straight plug
3. Service class
 - E—environmental open wire sealing
 - F—environmental open wire sealing with strain relief
4. Shell size
 - 10 thru 22 are available (page 3)
5. Insert arrangements
 - Complete listing of insert patterns (page 4)
6. Contacts
 - P designates pin, S designates sockets
7. Alternate insert rotation (page 3)
8. (SR) Suffix may be specified on class "F" connectors for conventional clamp assembly
9. Connector assemblies may be purchased less contacts by so stating

DC

specifications and insert availability, identification, alternate positions

CRIMP WELL DATA

Contact Size	Wire Well Data	
	20	16
Conductor Well Dia.	.048 +.002 -.000	.066 +.002 -.000
Conductor Well Depth	.189 +.037 -.000	.250 +.031 -.000
Insulation Well Dia.	.091 +.002 -.000	Not Applicable
Insulation Well Depth	.072 +.006 -.000	Not Applicable

CONTACT RATING

Contact Size*	Test Current*	Potential Drop Millivolts*
20	7.5	55
16	13	50

*See requirements per MIL-C-23216

WORKING VOLTAGE

Service Rating	Maximum Working Voltage			
	Sea Level		70,000 ft.	
	AC rms	DC	AC rms	DC
I	600	840	300	420
II	1000	1400	450	630

INSERT AVAILABILITY AND IDENTIFICATION – ALTERNATE POSITIONS

Insert Arrangement	Total Contacts	Contact Size		Service Rating	Alternate Positioning Degrees			
		16	20		W	X	Y	Z
10-6	6		6	I	90	*	*	*
12-3	3	3		II	*	*	180	*
12-8	8		8	I	90	112	203	292
12-10	10		10	I	60	155	270	295
14-5	5	5		II	40	92	184	273
14-15	15	1	14	I	17	110	155	234
14-18	18		18	I	15	90	180	270
14-19	19		19	I	30	165	315	*
16-8	8	8		II	54	152	180	331
16-26	26		26	I	60	*	275	338
18-11	11	11		II	62	119	241	340
18-32	32		32	I	85	138	222	265
20-16	16	16		II	238	318	333	347
20-39	39	2	37	I	63	144	252	333
20-41	41		41	I	45	126	225	*
22-21	21	21		II	16	135	175	349
22-55	55		55	I	30	142	226	314

*Indicated positions are not available.

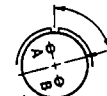

POSITION W

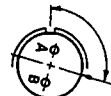

POSITION X

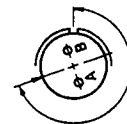

POSITION Y

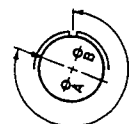

POSITION Z

Views looking into front face of pin insert or rear of socket insert.

DC insert arrangements

front face of pin inserts illustrated

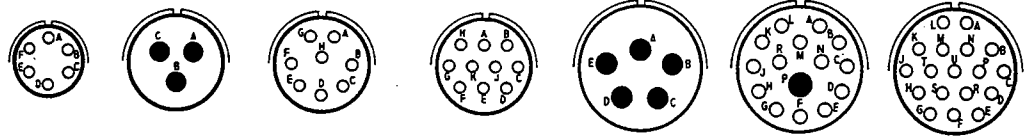

Insert Arrangement
Service Rating
Number of Contacts
Contact Size

10-6	12-3	12-8	12-10	14-5	14-15	14-18
I	II	I	I	II	I	I
6	3	8	10	5	1 14	18
20	16	20	20	16	16 20	20

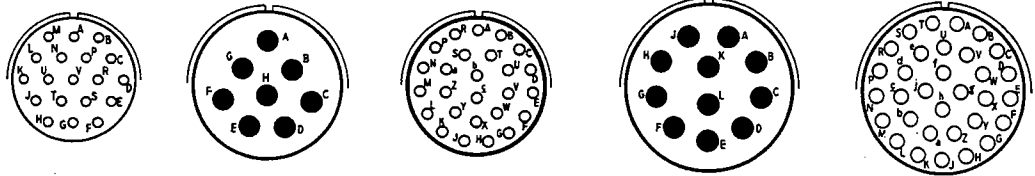

Insert Arrangement
Service Rating
Number of Contacts
Contact Size

14-19	16-8	16-26	18-11	18-32
I	II	I	II	I
19	8	25	11	32
20	16	20	16	20

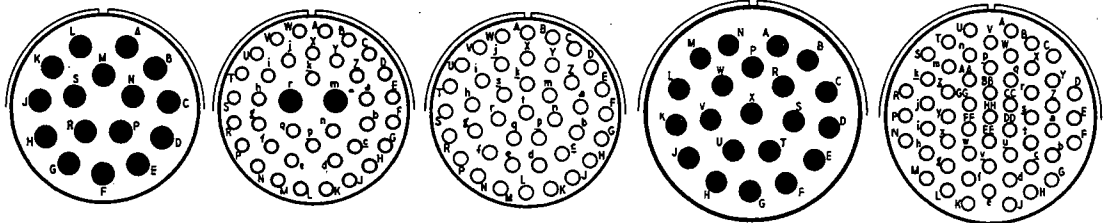

Insert Arrangement
Service Rating
Number of Contacts
Contact Size

20-16	20-39	20-41	22-21	22-55
II	I	I	II	I
16	2 37	41	21	55
16	16 20	20	16	20

● ○
CONTACT LEGEND 16 20

DC20 wall mounting receptacle

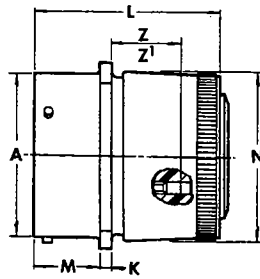
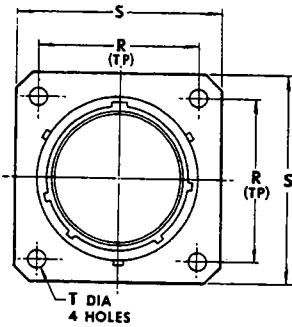

DC20E-XX-XX*

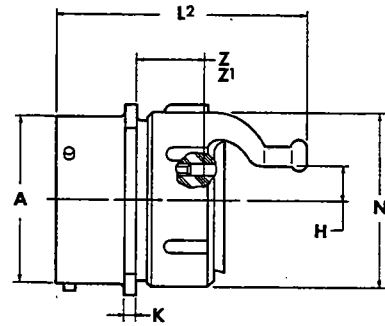

DC20F-XX-XX*

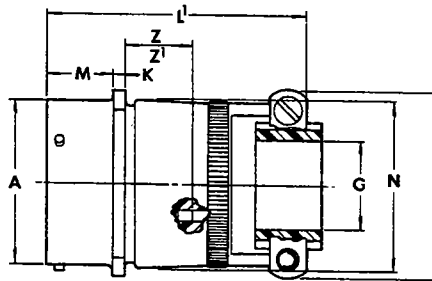

DC20F-XX-XX(SR)*

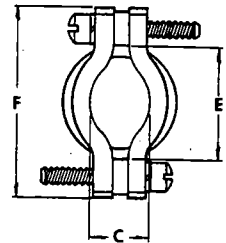

Z for pin contacts
Z' for socket contacts

*To complete order number, see page 2.

Shell Size	A Dia. +.001 -.005	K ±.016	M +.031 -.000	R (TP)	S Max.	T Dia. ±.005	L Max.	N Max.	L' Max.	L ² Max.	F Max.	G +.010 -.025 Free Dia.	H Radius ±.015	E Min.	C Closed Max.	Z ±.055	Z' ±.055
10	.590	.062	.431	.719	.954	.120	1.328	.691	1.922	2.656	.891	.188	.113	.297	.187	.509	.443
12	.750	.062	.431	.812	1.047	.120	1.328	.827	1.922	2.656	1.016	.312	.150	.422	.281	.509	.443
14	.875	.062	.431	.906	1.141	.120	1.328	.941	1.922	2.906	1.141	.375	.188	.547	.325	.509	.443
16	1.000	.062	.431	.969	1.234	.120	1.328	1.067	2.000	2.906	1.203	.500	.223	.609	.356	.509	.443
18	1.125	.062	.431	1.062	1.328	.120	1.328	1.191	2.000	2.906	1.469	.625	.281	.734	.456	.509	.443
20	1.250	.094	.556	1.156	1.453	.120	1.359	1.327	2.172	2.938	1.469	.625	.281	.734	.519	.414	.353
22	1.375	.094	.556	1.250	1.578	.120	1.359	1.452	2.172	2.938	1.656	.750	.303	.922	.519	.414	.353

All dimensions for reference only

DC21

cable connecting plug

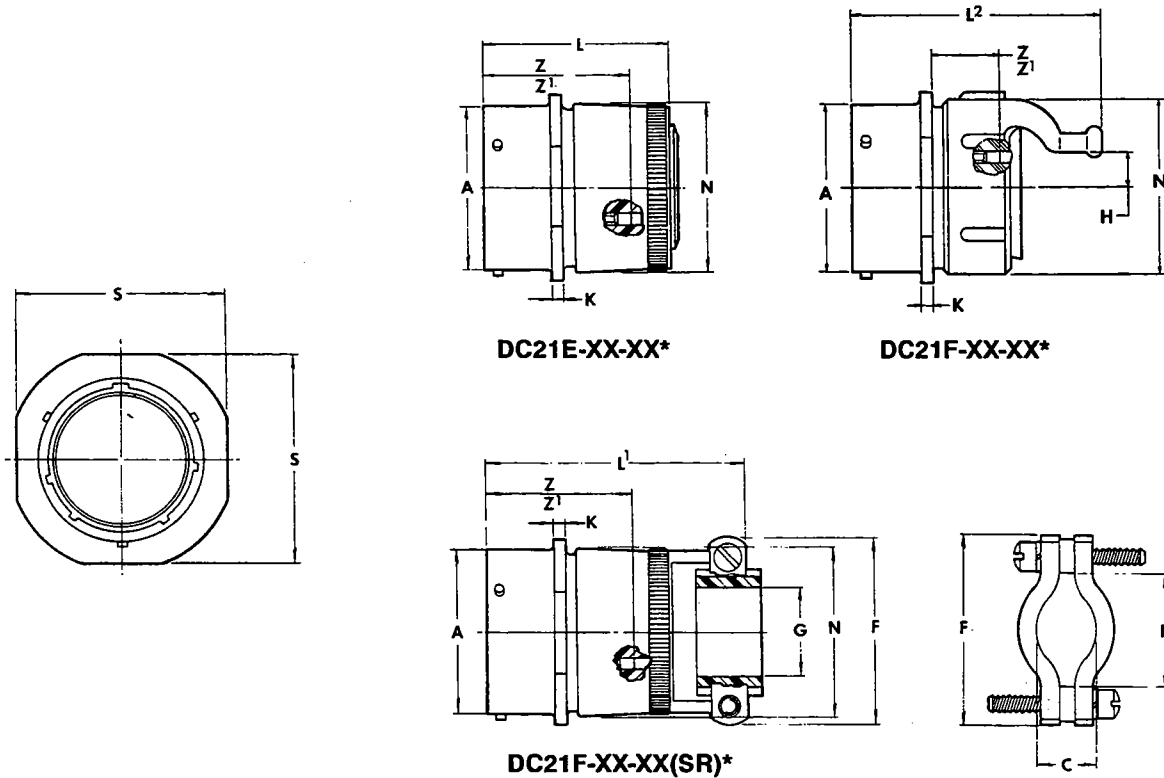

Z for pin contacts
Z' for socket contacts

*To complete order number, see page 2.

Shell Size	A Dia. +.001 -.005	K ±.016	S Max.	L Max.	N Max.	L ¹ Max.	L ² Max.	G +.010 -.025 Dia. Free	F Max.	Z ±.035	Z' ±.035	H Radius ±.015	E Min.	C Closed Max.
10	.590	.094	.955	1.328	.691	1.922	2.656	.188	.891	1.002	.941	.113	.297	.187
12	.750	.094	1.048	1.328	.827	1.922	2.656	.312	1.016	1.002	.941	.150	.422	.281
14	.875	.094	1.142	1.328	.941	1.922	2.906	.375	1.141	1.002	.941	.188	.547	.325
16	1.000	.094	1.236	1.328	1.067	2.000	2.906	.500	1.203	1.002	.941	.223	.609	.356
18	1.125	.094	1.329	1.328	1.191	2.000	2.906	.625	1.469	1.002	.941	.281	.734	.456
20	1.250	.115	1.455	1.359	1.327	2.172	2.938	.625	1.469	1.064	1.003	.281	.734	.519
22	1.375	.115	1.579	1.359	1.452	2.172	2.938	.750	1.656	1.064	1.003	.303	.922	.519

All dimensions for reference only

DC24

jam nut receptacle

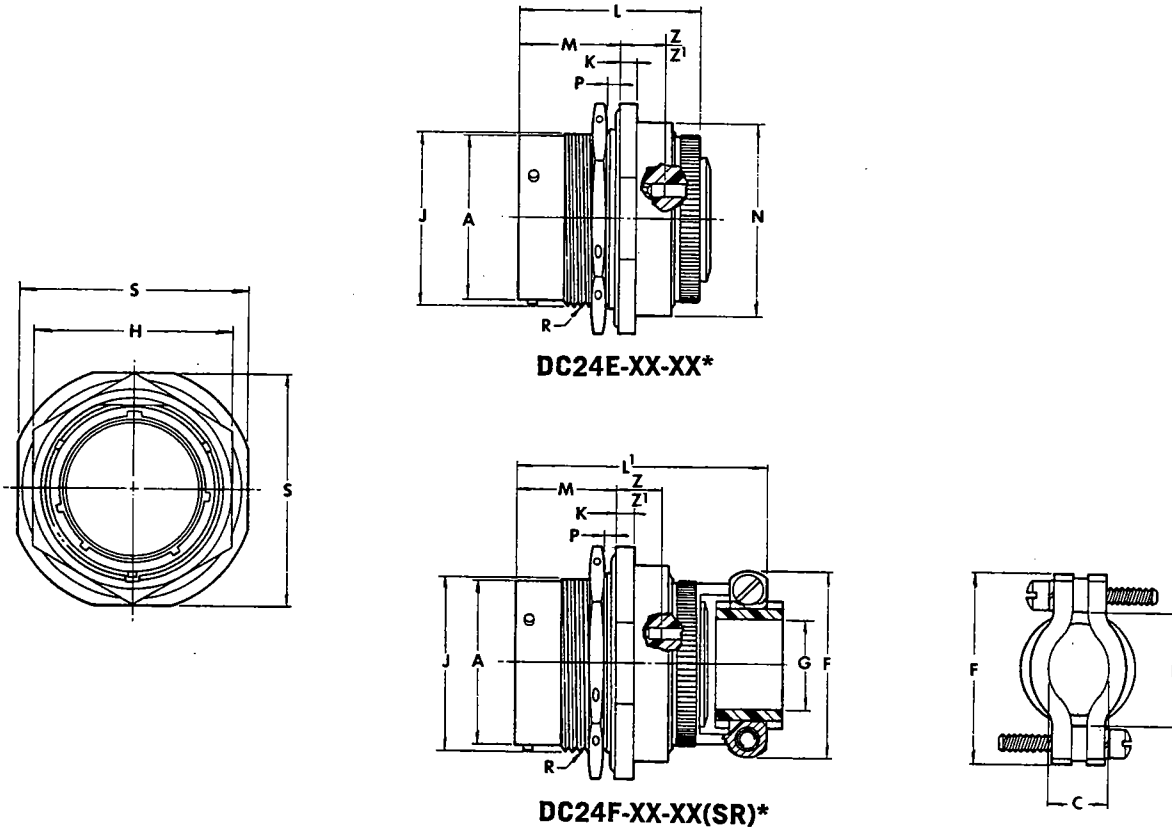

Z for pin contacts
Z' for socket contacts

*To complete order number, see page 2.

Shell Size	A Dia.	J Flat	K	M	H Hex Max.	P Panel Thickness		S Max.	L Max.	N Max.	L' Max.	F Max.	G +.010 -.025 Dia. Free	E Min.	C Closed Max.	R Thread Class 2A	Z ±.030	Z' ±.030
	+.001 -.005	+.000 -.010	+.011 -.010	±.005	Min.	Max.												
10	.590	.655	.125	.696	.892	.062	.125	1.078	1.438	.874	1.922	.891	.188	.297	.187	.6875-24UNEF	.293	.232
12	.750	.818	.125	.696	1.079	.062	.125	1.266	1.438	.999	1.922	1.016	.312	.422	.281	.8750-20UNEF	.293	.232
14	.875	.942	.125	.696	1.205	.062	.125	1.391	1.438	1.124	1.922	1.141	.375	.547	.325	1.0000-20UNEF	.293	.232
16	1.000	1.066	.125	.696	1.329	.062	.125	1.516	1.438	1.249	2.000	1.203	.500	.609	.356	1.1250-18UNEF	.293	.232
18	1.125	1.191	.125	.696	1.455	.062	.125	1.641	1.438	1.374	2.000	1.469	.625	.734	.456	1.2500-18UNEF	.293	.232
20	1.250	1.316	.156	.884	1.579	.062	.250	1.828	1.625	1.530	2.172	1.469	.625	.734	.519	1.3750-18UNEF	.167	.106
22	1.375	1.441	.156	.884	1.705	.062	.250	1.954	1.625	1.655	2.172	1.656	.750	.922	.519	1.5000-18UNEF	.167	.106

All dimensions for reference only

DC26 straight plug

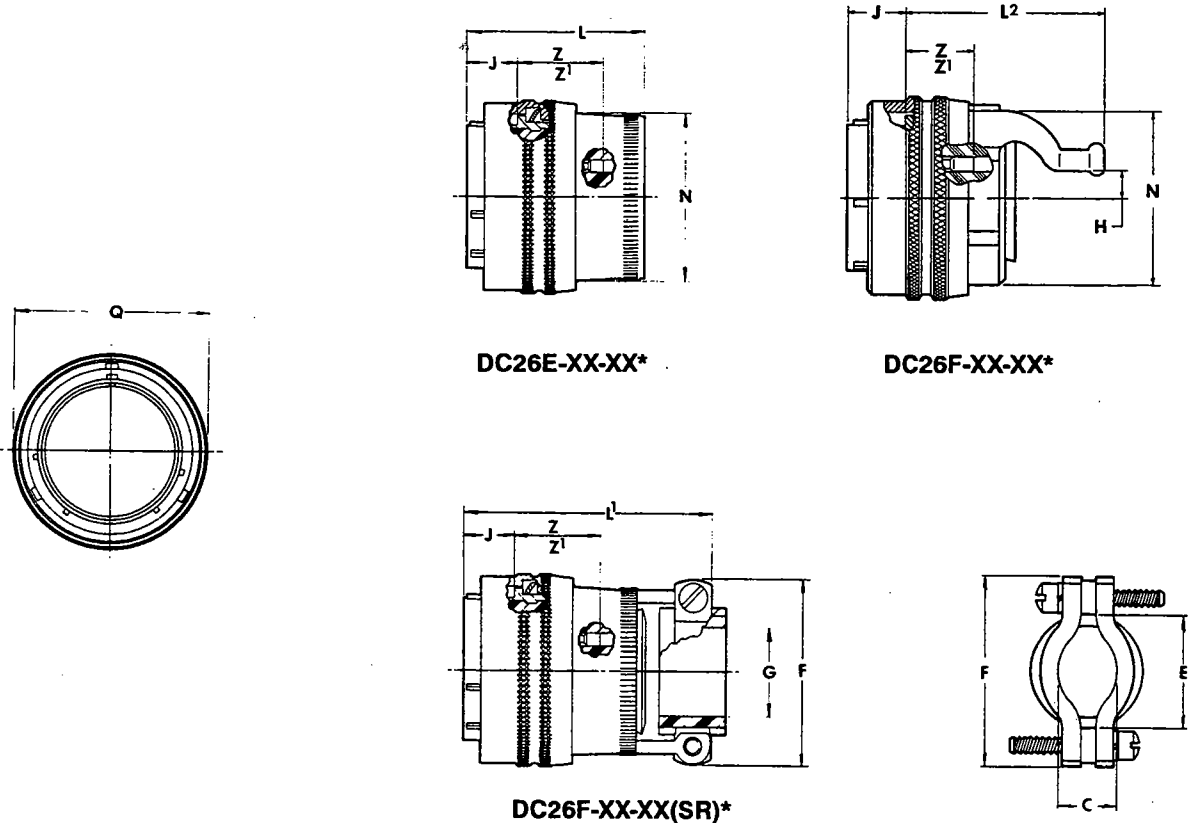

Z for pin contacts
Z' for socket contacts

*To complete order number, see page 2.

Shell Size	Q Dia. Max	L Max.	N Max.	L ¹ Max.	L ² Max.	G +.010 - .025 Dia. Free	F Max.	E Min.	H Radius ±.015	C Closed Max.	Z ±.045	Z' ±.045	J ±.010
10	.859	1.328	.691	1.922	2.281	.188	.891	.297	.113	.187	.640	.579	.353
12	1.031	1.328	.827	1.922	2.281	.312	1.016	.422	.150	.281	.640	.579	.353
14	1.156	1.328	.941	1.922	2.531	.375	1.141	.547	.188	.325	.640	.579	.353
16	1.281	1.328	1.067	2.000	2.531	.500	1.203	.609	.223	.325	.640	.579	.353
18	1.391	1.328	1.191	2.000	2.531	.625	1.469	.734	.281	.456	.640	.579	.353
20	1.531	1.297	1.327	2.109	2.406	.625	1.469	.734	.281	.519	.578	.517	.415
22	1.656	1.297	1.452	2.109	2.406	.750	1.656	.922	.303	.519	.578	.517	.415

All dimensions for reference only

DC**contacts and application tools**

Size	Contact	Crimp Tool	Turret Head	Inspection Tool	Removal Tool
20	Pin 10-314980-20P Socket 10-597820-355	M22520/1-01	M22520/1-02	11-8107-20 or 11-7401-20	11-7880-20
20/16WW	Pin 10-330930-20F Socket 10-330931-20F	M22520/1-01	M22520/1-02	11-8107-16 or 11-7401-16	11-7880-20
16	Pin 10-314980-16P Socket 10-257982-16F	M22520/1-01	M22520/1-02	11-8107-16 or 11-7401-16	11-7880-16
16/20WW	Pin 10-330932-16F Socket 10-330933-16F	M22520/1-01	M22520/1-02	11-8107-16 or 11-7401-20	11-7880-16

Bendix® 10-244 Series Connectors

operating temperature up to 400°

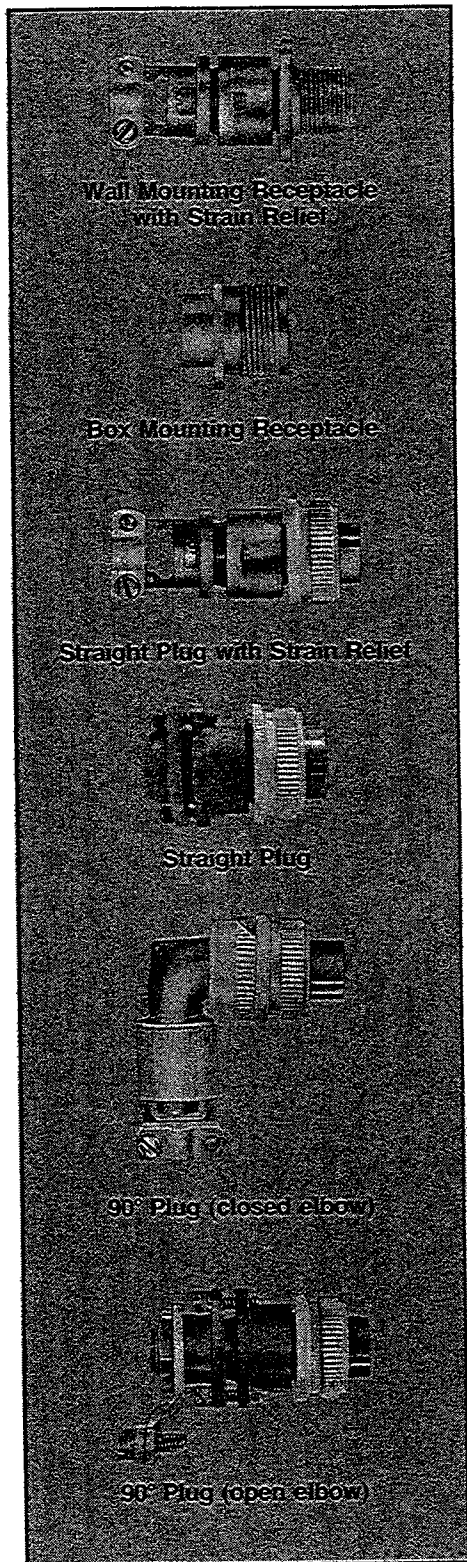

Bendix®10-244 type connectors have been specifically designed for aircraft engine compartment applications.

The combination of fluoroelastomer resilient parts, gray anodized hardware, and rhodium plated crimp contacts enables the connector to withstand operating temperatures up to 400°F.

Components

- The plug shells are machined from high grade aluminum alloy and the receptacle shells are die cast aluminum. This combination provides plugs with greater strength. All aluminum parts incorporate a gray anodized finish which provides added corrosion resistance.
- All of the resilient components are molded from a specially formulated fluoroelastomer compound which is highly resistant to turbine oils, kerosene and JP-4. This material will provide satisfactory operation when subjected to splashing of Skydrol 500.
- All connectors employ crimp type copper alloy rhodium plated contacts which are supplied with the connector. Nylon pilot pins are also supplied to aid in the insertion of the socket contacts.

How to Order

To more easily illustrate ordering procedure, part number 10-244218-1P is shown as follows:

$\frac{10-2442}{1} \quad \frac{18}{2} \quad - \quad \frac{1}{3} \quad \frac{P}{4}$

1. Connector type and shell style (pages 15—19)
2. Shell style
8 thru 28 (page 12)
3. Insert arrangement
Complete listing of insert patterns (pages 13—14)
4. Contact type and insert rotation (page 12)
P for pins, S for sockets in a normal rotation

Typically when an alternate position of the insert is required, this is indicated by adding another letter such as "W" to the ordering number. This part numbering system requires a single letter designation for insert rotations. Therefore, when alternate insert location is desired, select from the table below the one letter that indicates both the type of contacts and the insert location required and add it to the order number.

MS Letters	Bendix Letters	MS Letters	Bendix Letters
PW	G	SW	H
PX	I	SX	J
PY	K	SY	L
PZ	M	SZ	N

The order number for a 10-2442XX-XXX mounting receptacle in shell size 18 with an MS arrangement of 18-1 with pin contacts and with the insert located in alternate position "W" would be: 10-244218-1G.

10-244

specifications

CONTACT PART NUMBERS

Size	Pin Contact	Socket Contact
16 (Long)	10-229192-166	10-229193-166
16 (Short)	10-229192-156	10-229193-156
12	10-229192-126	10-229193-126
8	10-229192-86	10-229193-86

PILOT PINS

Size	Part No.
12	10-242758-12
16	10-242758-16
8	10-242758-8

WIRE WELL DATA

Contact Size	8	12	16
Well Dim.	.179 +.004 -.002	.098 +.004 -.000	.063 -.004 -.000
Well Depth +.031 -.000	.500	.250	.250

CONTACT RATING

Contact Size	Rated Current	Test Current	Potential Drop Millivolts Max.*
16	13	13	35
12	23	23	30
8	46	46	25

*End to end.

CONTACT ARRANGEMENT SERVICE RATING

MS Service	Recommended Operating Voltage at Sea Level		Test Voltage AC rms
	DC	AC rms	
Inst.	250	200	1000
A	700	500	2000
D	1250	900	2800
E	1750	1250	3500
B	2450	1750	4500
C	4200	3000	7000

10-244

insert availability, identification, alternate positions

Insert Arrangement	Total Contacts	Insert		Contact Size				Service Rating	Grommet			Alternate Positioning Degrees			
		Pin	Socket	4	8	12	16		90° Plug (Closed)	Wall Mt. Rec. Str. Plug	90° Plug (Open)	W	X	Y	Z
8S-1	1		X				1	A				*	*	*	*
10S-2	1		X				1	A	X	X		*	*	*	*
10SL-3	3	X	X				3	A	X	X	X	*	*	*	*
10SL-4	2	X	X				2	A	X	X		*	*	*	*
12S-3	2	X	X				2	A	X	X	X	70	145	215	290
14S-2	4	X	X				4	Inst.	X	X		*	120	240	*
14S-5	5	X	X				5	Inst.	X	X	X	*	110	*	*
14S-6	6	X	X				6	Inst.		X		*	*	*	*
14S-7	3	X	X				3	A	X						
14S-9	2	X	X				2	A	X	X	X	70	145	215	290
16S-1	7	X	X				7	A	X	X		80	*	*	280
16S-8	5	X	X				5	A	X	X		*	170	265	*
16-11	2	X	X			2		A		X		35	110	250	325
16-13	2	X	X			2		A		X		35	110	250	325
18-1	10	X	X				10	**	X	X		70	145	215	290
18-4	4	X	X				4	D		X		35	110	250	325
18-8	8		X			1	7	A		X		70	*	*	290
18-12	6	X	X				6	A		X		80	*	*	280
18-19	10	X	X				10	A	X	X		*	120	240	*
18-22	3		X				3	D	X			70	145	215	290
20-15	7	X	X			7		A				80	*	*	280
20-27	14	X	X				14	A		X		35	110	250	325
20-29	17	X	X				17	A	X	X		80	*	*	280
22-14	19	X	X				19	A		X		80	110	250	280
22-19	14	X	X				14	A	X			80	110	250	280
22-22	4		X		4			A		X		*	110	250	*
22-28	7		X			7		A		X		80	*	*	280
24-2	7		X			7		D		X		80	*	*	280
24-22	4	X	X		4			D		X		45	110	250	*
28-2	14	X	X			2	12	D		X		35	110	250	325
28-9	12	X	X			6	6	D		X		80	110	250	280
28-11	22		X			4	18	A		X		80	110	250	280
28-21	37	X	X				37	A		X		80	110	250	280
28-22	6		X	3			3	D		X		70	145	215	290

*Indicated positions are not available.

**B, C, F, G = A, Balance = Inst.

10-244

insert arrangements

front face of pin inserts illustrated



Insert Arrangement	8S-1	10S-2	10SL-4	10SL-3	12S-3	14S-2	14S-5
Service Rating	A	A	A	A	A	Inst.	Inst.
Number of Contact	1	1	2	3	2	4	5
Contact Size	16	16	16	16	16	16	16

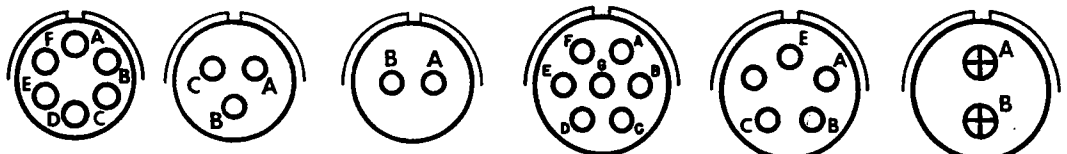

Insert Arrangement	14S-6	14S-7	14S-9	16S-1	16S-8	16-11
Service Rating	Inst.	A	A	A	A	A
Number of Contacts	6	3	2	7	5	2
Contact Size	16	16	16	16	16	12

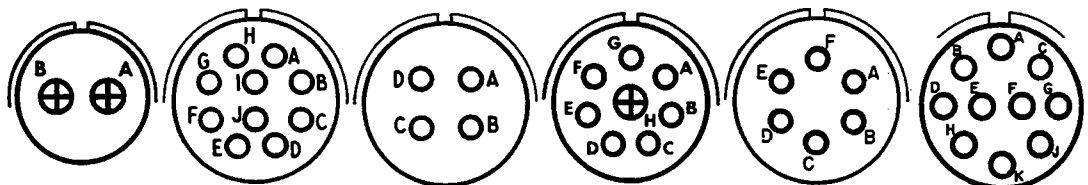

Insert Arrangement	16-13	18-1	18-4	18-8	18-12	18-19
Service Rating	A	*	D	A	A	A
Number of Contacts	2	10	4	1 7	6	10
Contact Size	12	16	16	12 16	16	16

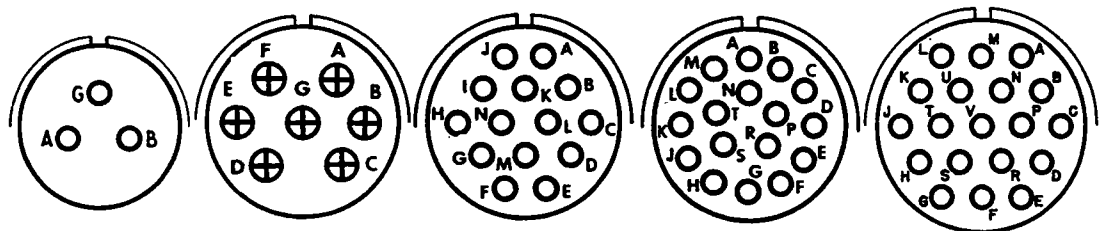

Insert Arrangement	18-22	20-15	20-27	20-29	22-14
Service Rating	D	A	A	A	A
Number of Contacts	3	7	14	17	19
Contact Size	16	12	16	16	16



*B, C, F, G = A, Balance = Inst.

CONTACT LEGEND

10-244

insert arrangements

front face of pin inserts illustrated

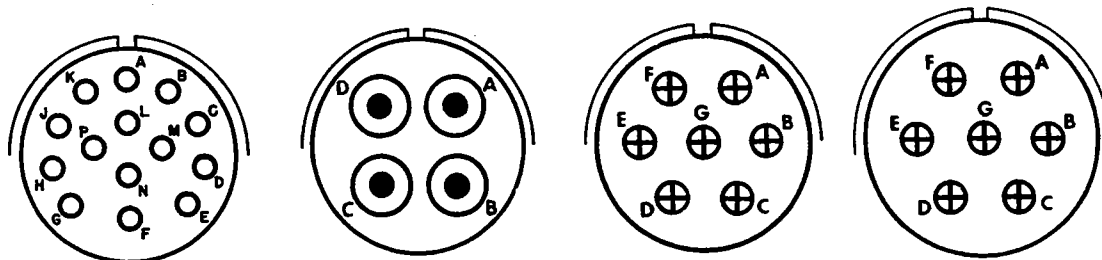

Insert Arrangement
Service Rating
Number of Contacts
Contacts Size

22-19
A
14
16

22-22
A
4
8

22-28
A
7
12

24-2
D
7
12

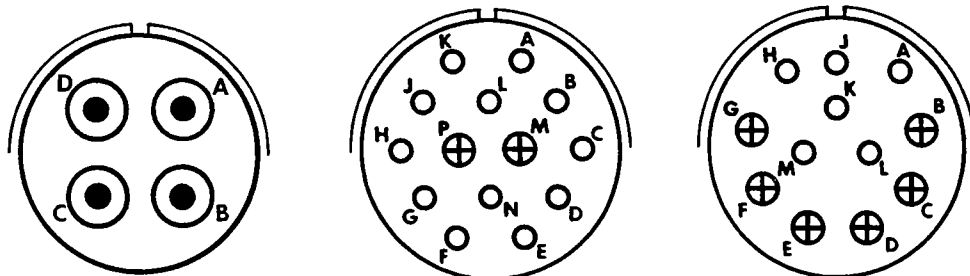

Insert Arrangement
Service Rating
Number of Contacts
Contact Size

24-22
D
4
8

28-2
D
2 12
12 16

28-9
D
6 6
12 16

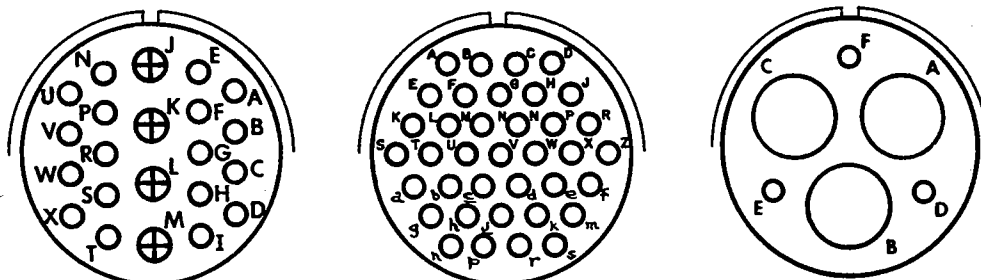

Insert Arrangement
Service Rating
Number of Contacts
Contact Size

28-11
A
4 18
12 16

28-21
A
37
16

28-22
D
3 3
4 16

CONTACT LEGEND

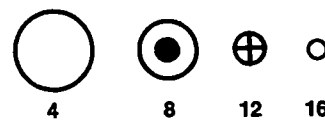

10-2440

wall mounting receptacle

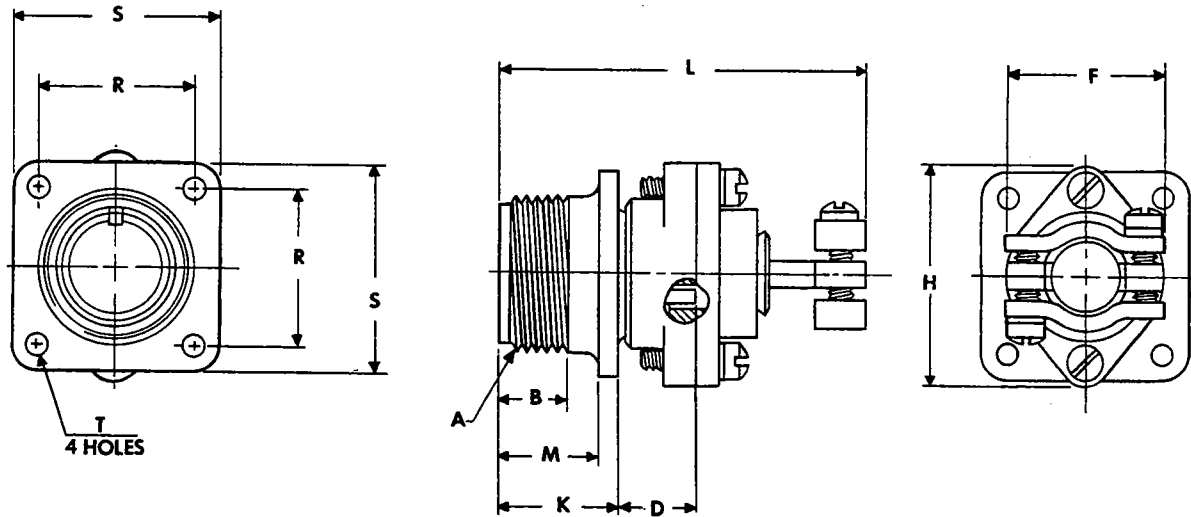

10-2440XX-XX*

*To complete order number, see page 10.
For insert and grommet availability, see page 12.

Order Number*	Shell Size	A Thread Class 2A	B Min. Full Thread	F Max.	H Max.	K +.020 - .010	L Max.	M +.010 - .000	R ±.005	S	T Dia. +.004 - .002	D ±.060
10-244010	10S	.6250-24NEF	.391	.775	1.026	.672	2.192	.562	.719	1.000	.120	.469
10-244011	10SL	.6250-24NEF	.391	.837	1.120	.672	2.192	.562	.719	1.000	.120	.469
10-244012	12S	.7500-20UNEF	.450	.837	1.120	.672	2.192	.562	.812	1.094	.120	.469
10-244013	12	.7500-20UNEF	.625	.837	1.120	.860	2.536	.750	.812	1.094	.120	.672
10-244014	14S	.8750-20UNEF	.450	.963	1.307	.672	2.192	.562	.906	1.188	.120	.469
10-244015	14	.8750-20UNEF	.625	.963	1.307	.860	2.536	.750	.906	1.188	.120	.672
10-244016	16S	1.0000-20UNEF	.450	1.087	1.432	.672	2.192	.562	.969	1.281	.120	.469
10-244017	16	1.0000-20UNEF	.625	1.087	1.432	.860	2.536	.750	.969	1.281	.120	.672
10-244018	18	1.1250-18NEF	.625	1.150	1.557	.891	2.661	.750	1.062	1.375	.120	.641
10-244020	20	1.2500-18NEF	.625	1.399	1.744	.891	2.661	.750	1.156	1.500	.120	.641
10-244022	22	1.3750-18NEF	.625	1.399	1.869	.891	2.661	.750	1.250	1.625	.120	.641
10-244024	24	1.5000-18NEF	.625	1.587	1.994	.953	2.739	.812	1.375	1.750	.147	.578

All dimensions for reference only

10-2442

box mounting receptacle

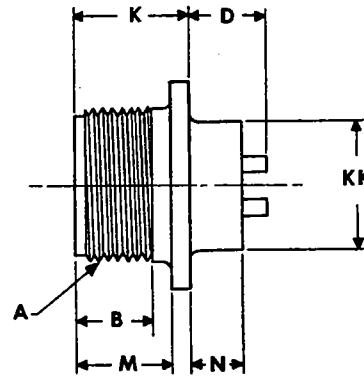
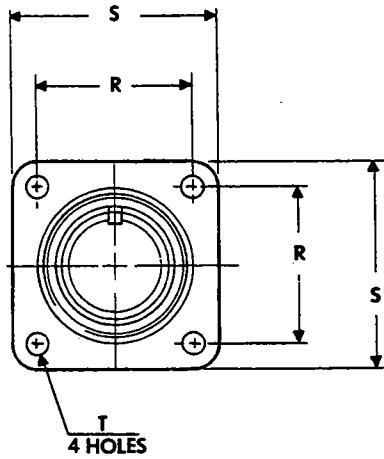

10-2442XX-XX*

*To complete order number, see page 10.
For insert and grommet availability, see page 12.

Order Number*	Shell Size	A Thread Class 2A	B Min. Full Thread	K +.020 -.010	M +.010 -.000	N +.000 -.010	R ±.005	S	T Dia. +.004 -.002	D +.050 -.060	KK Dia. +.010 -.000
10-244210	10S	.6250-24NEF	.391	.672	.562	.297	.719	1.000	.120	.679	.500
10-244211	10SL	.6250-24NEF	.391	.672	.562	.297	.719	1.000	.120	.679	.625
10-244212	12S	.7500-20UNEF	.450	.672	.562	.297	.812	1.094	.120	.679	.625
10-244213	12	.7500-20UNEF	.625	.860	.750	.484	.812	1.094	.120	.672	.625
10-244214	14S	.8750-20UNEF	.450	.672	.562	.297	.906	1.188	.120	.679	.750
10-244215	14	.8750-20UNEF	.625	.860	.750	.484	.906	1.188	.120	.672	.750
10-244216	16S	1.0000-20UNEF	.450	.672	.562	.297	.969	1.281	.120	.679	.875
10-244217	16	1.0000-20UNEF	.625	.860	.750	.484	.969	1.281	.120	.672	.875
10-244218	18	1.1250-18NEF	.625	.891	.750	.453	1.062	1.375	.120	.641	1.000
10-244220	20	1.2500-18NEF	.625	.891	.750	.453	1.156	1.500	.120	.641	1.125
10-244222	22	1.3750-18NEF	.625	.891	.750	.453	1.250	1.625	.120	.641	1.250

All dimensions for reference only

10-2446 straight plug

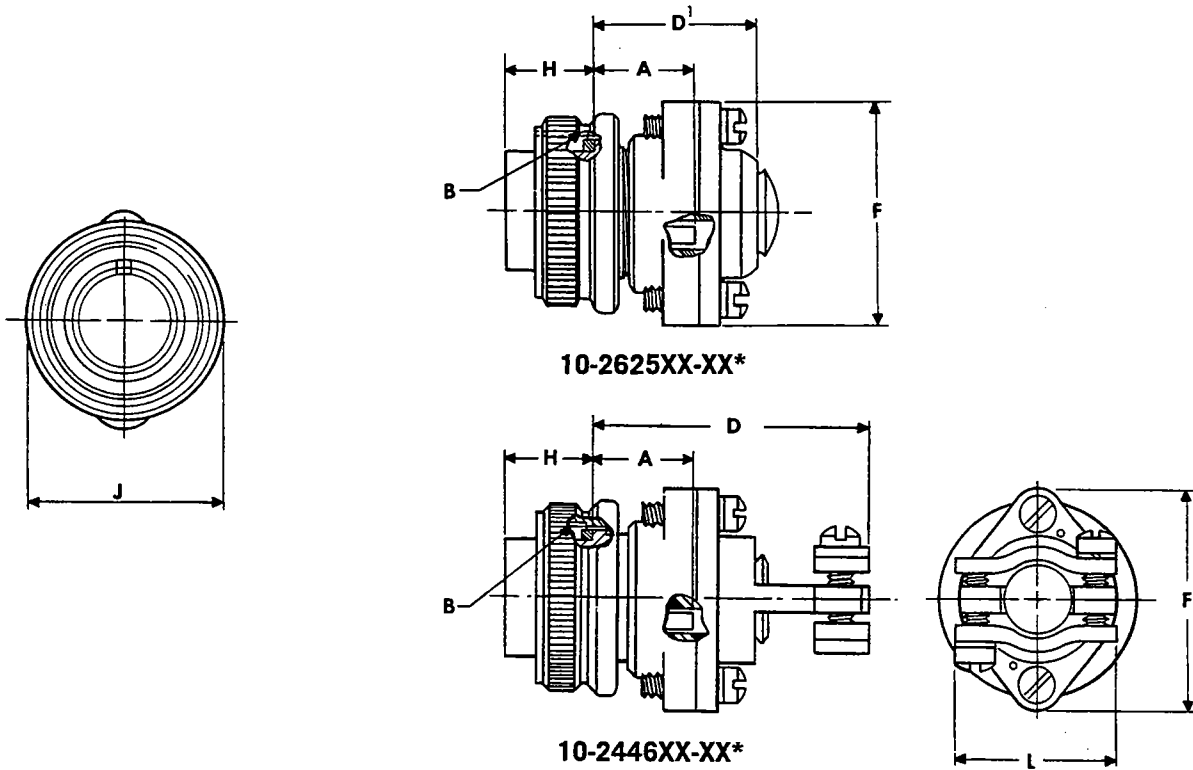

*To complete order number, see page 10.
For insert and grommet availability, see page 12.

Order Number*		Shell Size	A ±.045	B Thread Class 2B	D Max.	D' Max.	H ±.005	J Dia. Max.	F Dia. Max.	L Max.
Without Strain Relief	With Strain Relief									
10-262581	10-244610	10S	.609	.6250-24UNEF	1.661	1.057	.531	.869	1.026	.775
10-262582	10-244611	10SL	.609	.6250-24UNEF	1.661	1.057	.531	.945	1.120	.837
10-262583	10-244612	12S	.609	.7500-20UNEF	1.661	1.057	.531	.955	1.120	.837
10-262584	10-244613	12	.812	.7500-20UNEF	1.817	1.212	.719	.955	1.120	.837
10-262585	10-244614	14S	.609	.8750-20UNEF	1.661	1.057	.531	1.123	1.307	.963
10-262586	10-244615	14	.812	.8750-20UNEF	1.817	1.212	.719	1.123	1.307	.963
10-262587	10-244616	16S	.609	1.0000-20UNEF	1.661	1.057	.531	1.250	1.432	1.087
10-262588	10-244617	16	.812	1.0000-20UNEF	1.942	1.212	.719	1.250	1.432	1.087
10-262589	10-244618	18	.812	1.1250-18UNEF	1.942	1.212	.719	1.333	1.557	1.150
10-262590	10-244620	20	.812	1.2500-18UNEF	1.942	1.212	.719	1.461	1.744	1.399
10-262591	10-244622	22	.812	1.3750-18UNEF	1.942	1.212	.719	1.588	1.869	1.399
10-262592	10-244624	24	.812	1.5000-18UNEF	2.021	1.291	.719	1.715	1.994	1.587
10-262593	10-244628	28	.812	1.7500-18UNS	2.021	1.291	.719	1.968	2.166	1.587

All dimensions for reference only

10-2448

90° plug (closed)

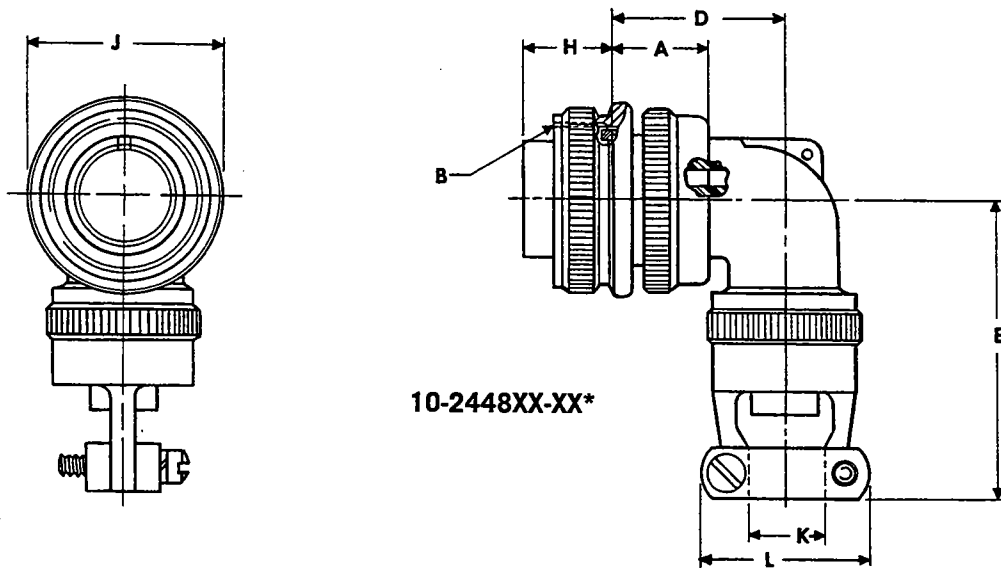

*To complete order number, see page 10.
For insert and grommet availability, see page 12.

Order Number*	Shell Size	A ±.045	B Thread Class 2B	D Max.	E Max.	H ±.005	J Dia. Max.	K Dia.	L Max.
10-244810	10S	.609	.6250-24UNEF	.927	1.706	.531	.869	.250	.775
10-244811	10SL	.609	.6250-24UNEF	.951	1.769	.531	.945	.312	.837
10-244812	12S	.609	.7500-20UNEF	.956	1.769	.531	.995	.312	.837
10-244813	12	.812	.7500-20UNEF	1.143	1.769	.719	.995	.312	.837
10-244814	14S	.609	.8750-20UNEF	1.020	1.831	.531	1.123	.438	.963
10-244815	14	.812	.8750-20UNEF	1.207	1.831	.719	1.123	.438	.963
10-244816	16S	.609	1.0000-20UNEF	1.146	1.894	.531	1.250	.562	1.087
10-244817	16	.812	1.0000-20UNEF	1.333	1.894	.719	1.250	.562	1.087
10-244818	18	.812	1.1250-18UNEF	1.395	2.099	.719	1.333	.625	1.150
10-244820	20	.812	1.2500-18UNEF	1.598	2.224	.719	1.461	.750	1.400
10-244822	22	.812	1.3750-18UNEF	1.598	2.286	.719	1.588	.750	1.400

All dimensions for reference only

10-2484

90° plug (open)

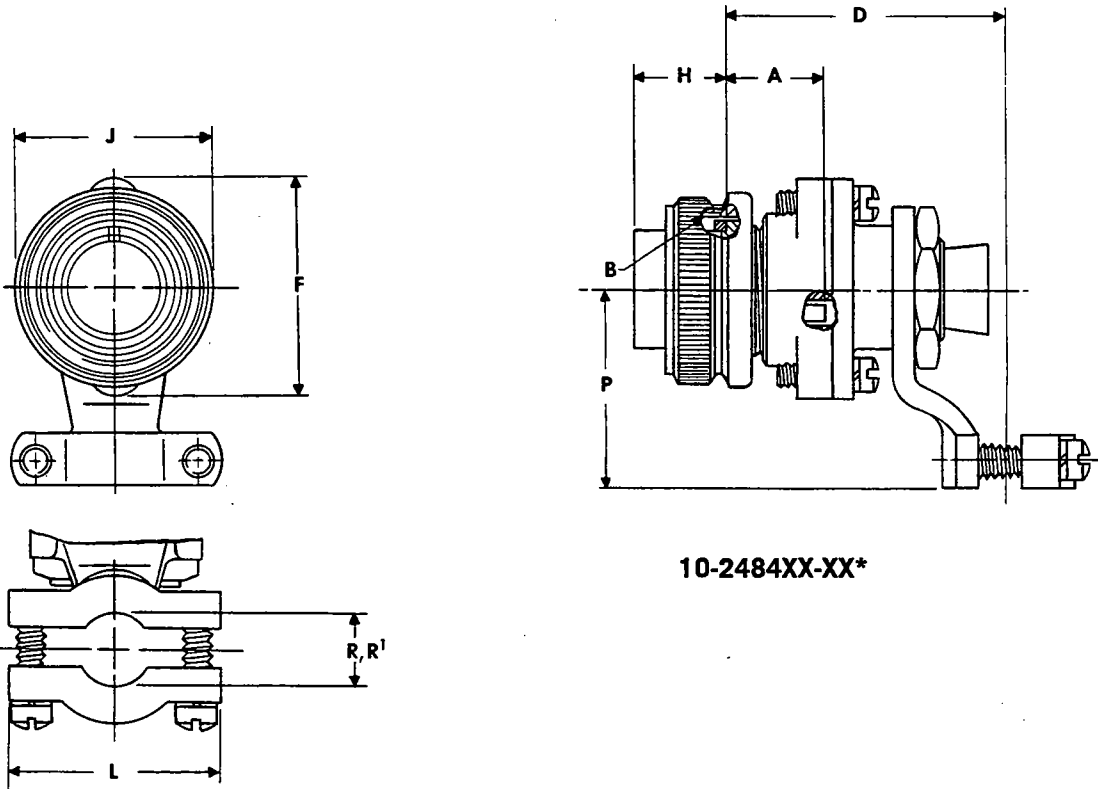

10-2484XX-XX*

*To complete order number, see page 10.
For insert and grommet availability, see page 12.

Order Number*	Shell Size	A ±.045	B Thread Class 2B	D Max.	F Dia. Max.	H ±.005	J Dia. Max.	L Max.	P Max.	R Max. Cable	R ₁ Min. Cable
10-248481	10S	.609	.6250-24UNEF	1.463	1.026	.531	.869	.755	1.016	.172	.082
10-248482	10SL	.609	.6250-24UNEF	1.463	1.120	.531	.946	.817	1.078	.281	.114
10-248483	12S	.609	.7500-20UNEF	1.518	1.120	.531	.995	.817	1.078	.281	.114
10-248484	12	.812	.7500-20UNEF	1.674	1.120	.719	.995	.817	1.078	.281	.114
10-248485	14S	.609	.8750-20UNEF	1.674	1.307	.531	1.123	.943	1.203	.406	.176
10-248486	14	.812	.8750-20UNEF	1.830	1.307	.719	1.123	.943	1.203	.406	.176
10-248487	16S	.609	1.0000-20UNEF	1.731	1.432	.531	1.250	1.067	1.265	.500	.238
10-248488	16	.812	1.0000-20UNEF	1.883	1.432	.719	1.250	1.067	1.265	.500	.238
10-248489	18	.812	1.1250-18UNEF	1.933	1.557	.719	1.333	1.149	1.328	.531	.208
10-248490	20	.812	1.2500-18UNEF	2.025	1.744	.719	1.461	1.399	1.359	.656	.302
10-248491	22	.812	1.3750-18UNEF	2.072	1.859	.719	1.588	1.399	1.421	.750	.302

All dimensions for reference only

10-244

contacts and application tools

Size	Contacts	Pilot Pins	Crimp Pins	Turret Hd. Daniels Mfg. Corp.	Turret Hd. Buchanan	Insertion Tool	Removal Tool
16L	Pin 10-229192-166	—	M22520/1-01	TH29-1	616266	11-7345	11-8250
	Socket 10-229193-166	10-242758-16	M22520/1-01	TH29-1	616266	11-7345	11-8250
16S	Pin 10-229192-156	—	M22520/1-01	TH29-1	616266	11-7345	11-8250
	Socket 10-229193-156	10-242758-16	M22520/1-01	TH29-1	616266	11-7345	11-8250
12	Pin 10-229192-126	—	M22520/1-01	TH29-1	616266	11-7082	11-8250
	Socket 10-229193-126	10-242758-12	M22520/1-01	TH29-1	616266	11-7082	11-8250
8	Pin 10-229192-86	—	11-7838-1 and locator 11-7740-5			11-8220	11-8250
	Socket 10-229193-86	10-242758-8	11-7838-1 and locator 11-7740-5			11-8220	11-8250

See L-757 for installation instructions.
11-8250 Kit includes tips for contact size 16, 12, and 18.

Bendix® BT High Temperature Connectors

ceramic inserts

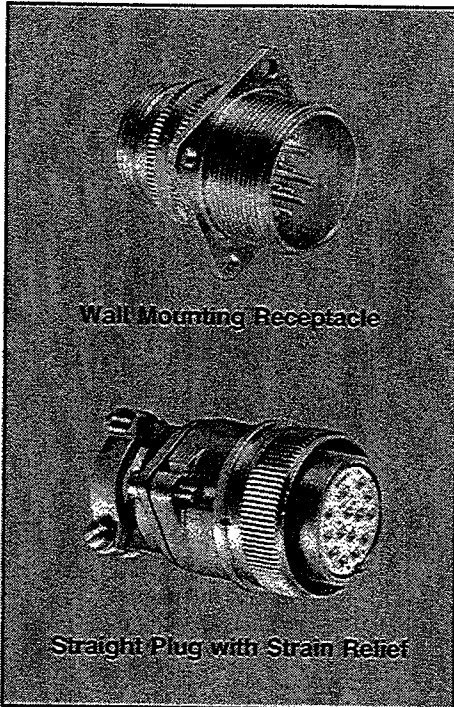

BT-M Connectors

The Bendix® "BT-M" firewall electrical connectors were specially designed for service where high temperature performance and direct exposure to flame are prevalent.

It is important to note that the "BT-M" series is divided into two categories. The first category, "BT-M", utilizes a MS-R type silicone grommet and clamp for termination of open wiring. The second category, the "BT-MA", utilizes a conduit adapter for termination of cable conduit.

The "BT-M" series connector will maintain a functional circuit under extreme heat of 2000°F for 5 minutes. It will also sustain a flame barrier for an additional 15 minutes. Continuous duty at an elevated temperature up to 450°F is assured.

Components

- Stainless Steel Shells provide added durability and resistance to corrosion.
- High density alumina oxide/silicone inserts provide increased performance in the following characteristics:
 - High resistance to vibration damage
 - Durability
 - Over all connector reliability
- Crimped type, gold plated contacts designed for use with wire conforming to MIL-W-5086 requirements.

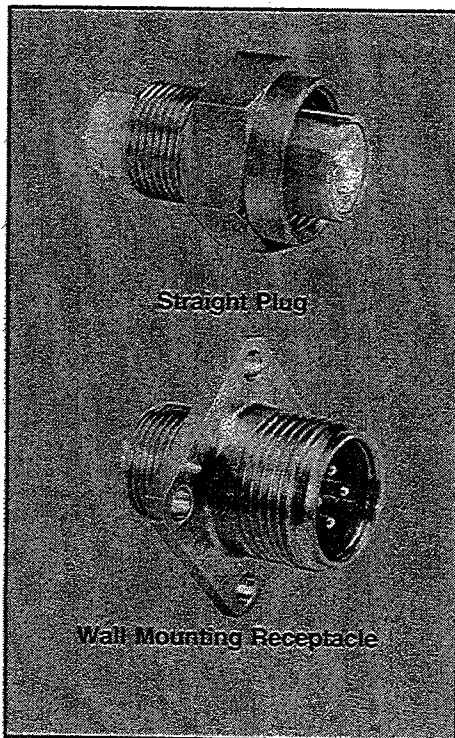

BT-RA Connectors

The Bendix® BT-RA connector meets the applicable requirements of Class A connectors to MIL-C-5015D and will operate continuously at temperatures up to 1000° F. Interchangeability and interchangeability with MIL-C-5015 connectors is assured. This connector series features rear removable crimp type contacts to ease assembly procedures and provides very little change in millivolt drop (contact resistance) during and after exposure to high temperature and vibration.

Components

- Shells and coupling nuts are fabricated from stainless steel to provide durability and resistance to corrosion and high temperature.
- Contacts are machined from nickel and are heavy gold plated for excellent electrical properties at high temperatures.
- Inserts are ceramic moldings and contain spring clips for retaining contacts. This combination of materials and plating also provides resistance to radiation and oxidation.

Note: Consult factory regarding availability and how to order of BT Connectors.

Bendix® Commercial Aircraft specials

A BT-RA type electrical connector in PC miniature cylindrical shell sizes and insert arrangements is presently available in a limited number of insert arrangements. This connector series is designated POBT-RA and will meet all the performance characteristics of the standard BT-RA. For specific information on this connector series, consult our factory.

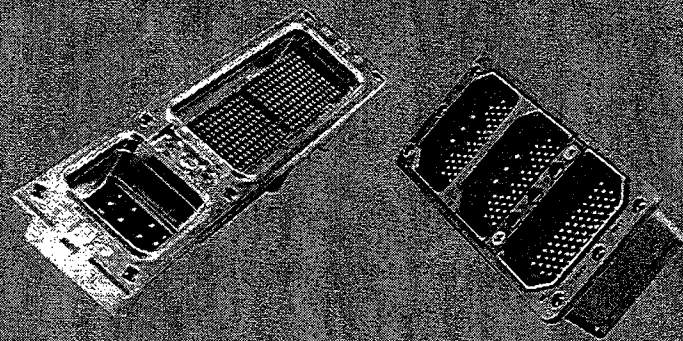
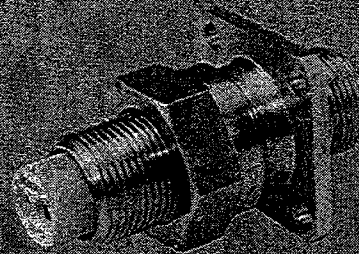

In addition to the cylindricals covered in this section, Amphenol/Bendix has available many rectangular connectors, such as the ARINC 404 and 600, that are applicable to aircraft installations. Ask for publications SL-378 and SL-379, both ARINC Back and Panel Connectors, and SL-375, ARINC Transient Protection Connectors.

Stainless Steel Connectors for engine and firewall applications are available in military and commercial designations. Bendix® and Pyle® connectors meet or exceed the firewall/high temperature requirements of MIL-C-38999 and MIL-C-83723. Contact the factory for additional information.

