

Contact, Socket, Triaxial Type LJT-R and TV-R Crimp (MIL-DTL-38999 Series I & III Electrical Connectors)

Standard contact arrangements available in Series I and III are 17-2, 21-75, 21-79, 25-7, 25-17, 25-26 and 25-46. Contact is supplied with a piggyback grommet seal. See table on reverse side for triax cable recommended, tool selector settings, crimping tool and positioner information.

Installation Instructions

- Slide piggyback grommet seal over the cable jacket, soft rubber end first.
 - Slide the outer crimp bushing, flange end first, over the outer cable jacket. Secure in place with a piece of tape that can be removed later.
 - Strip cable outer jacket .850 inches as shown. Do not cut or nick shield wire strands under jacket.
 - Strip cable shield to .350 inches from end of crimp bushing and carefully form strands back over crimp bushing as evenly as possible. Do not comb out the shield strands.
 - Trim the shield strands even to .015 inch max from front of crimp bushing forward flange.
 - Slide insulator spacer bushing, flange end first, over the cable interlayer and butt firmly against the shield strands formed over the crimp bushing end.
 - Slide the intermediate crimp bushing, flange end first, over the cable interlayer and firmly butt against the insulator spacer bushing.
 - Strip cable interlayer ahead of intermediate crimp bushing. Use caution not to cut or nick the inner shield wire strands under the interlayer.
 - Trim cable inner shield to .110 inches ahead of the intermediate crimp bushing end and carefully form strands back over crimp bushing as evenly as possible. Do not comb out the shield strands.
 - Trim shield strands even to .015 inches from front of intermediate crimp bushing flange.
 - Strip cable core .100 inches from shield formed over intermediate crimp bushing end. Do not cut or nick strands of cable center conductor when removing cable core insulation.
 - Slide front insulator, large end first, over cable center conductor and cable core until insulator butts firmly against the cable shield that is formed over the intermediate crimp bushing end. Be sure all strands of the cable center conductor appear through the end of the front insulator and that no cable intermediate shield strands have entered the rear opening of the front insulator. (An electrical check at this time may be performed to insure electrical isolation. Also after step 13.)
 - Trim fit the inner socket contact to the cable center conductor. The inner socket contact must butt against the end of the front insulator and the cable center conductor must be visible in the inner socket contact wire well inspection hole.
 - Crimp inner socket contact to cable center conductor using tool part number M22520/2-01 and Daniels Mfg. Co. tool contact positioner part number "K873". The tool indenter selector setting shall be "3".
 - Carefully slide the intermediate pin contact with its insulator installed, over the inner socket contact, front insulator and on over the intermediate crimp bushing and shield until the inner socket contact is firmly seated in the insulator recess of the intermediate pin contact assembly. A small gap may appear between the crimp bushing front flange and the intermediate contact end, due to contact and assembly tolerances.
 - Crimp intermediate contact and bushing flange simultaneously using crimp tools listed in table on back. Observe the .325 crimp length shown.
- CAUTION: DO NOT PULL ON THIS ASSEMBLY AFTER CRIMPING.**
- Slide outer socket contact with insulator already installed, over the crimped intermediate pin contact, spacer insulator bushing and shield formed over rear crimp bushing, until intermediate pin contact is fully seated in the outer contact insulator recess. A small gap may appear between the crimp bushing front flange and the outer socket contact end due to contact and assembly tolerances.
 - Crimp the outer socket contact and crimp bushing simultaneously using crimp tools listed in table on back. Observe the .240 - .270 crimp length shown. (Remove tape used to hold crimp bushing in position on cable during assembly).

CONTACT INSERTION INTO CONNECTOR

Hand insert the contact assembly through proper grommet opening until contact firmly seats inside the connector insert cavity. Tug slightly on cable to insure contact has properly seated in the insert retention device. Slide the piggyback grommet seal down the cable until the hard plastic portion comes to a firm butt inside the grommet cavity.

CONTACT REMOVAL FROM CONNECTOR

Slide the piggyback grommet seal up the cable and out of connector grommet cavity approximately 1.000 inch. Position Daniels Mfg. Co. removal tool part number "DRK264-8" around the cable jacket and slide tool down the cable until tool tips enter the rear grommet and come to a positive stop. Hold the tool tip firmly against the positive stop on the contact and grip the cable jacket and simultaneously remove tool, contact and cable.

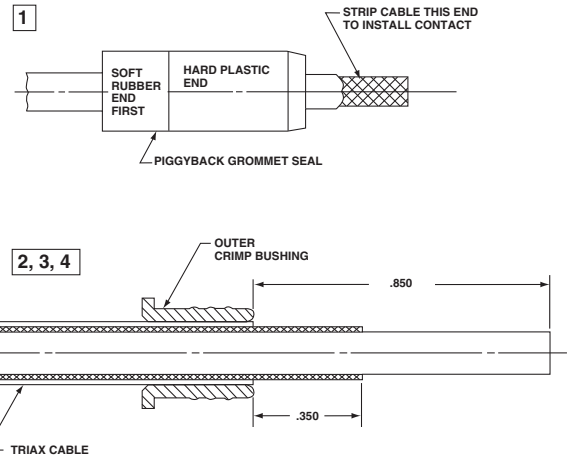

Amphenol

L-1254-AG
December 2018
FSCM 77820

AMPHENOL CORPORATION
Amphenol Aerospace
40-60 Delaware Avenue
Sidney, New York 13838-1395

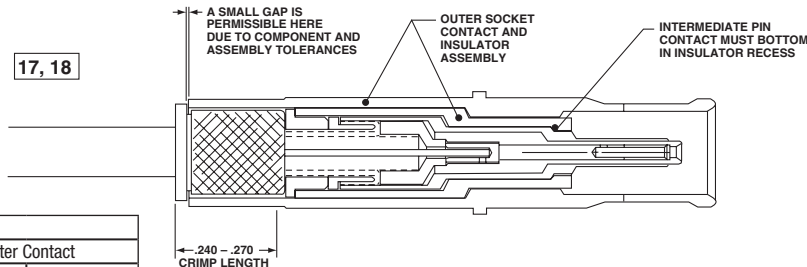
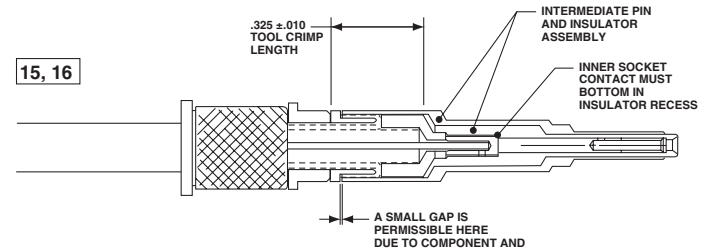
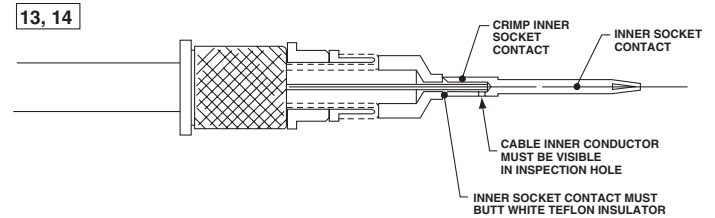
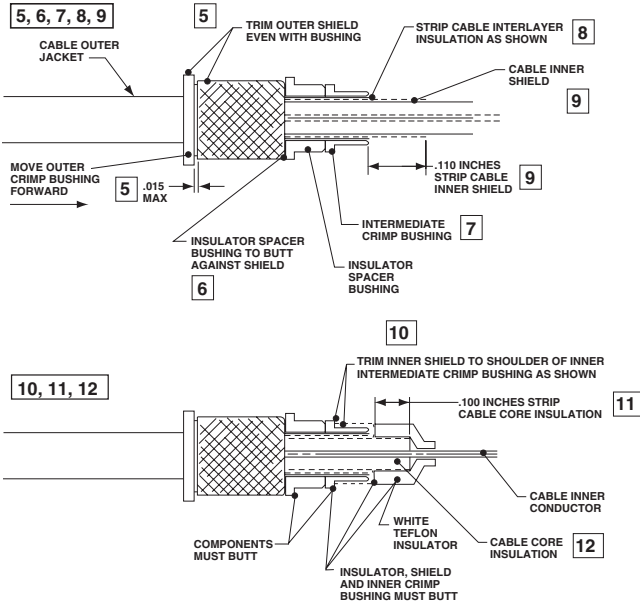

Part Number	Triax Cable Recommended	Tools					
		Inner Contact		Intermediate Contact		Outer Contact	
		Tool (Setting)	Positioner	Tool	Die Set (Location)	Tool	Die Set (Location)
21-033197-041	GORE GSC-03- 81497-00	M22520/2-01 (3)	Daniels K873	M22520/5-01	M22520/5-05 (B) (.178 hex)	M22520/5-01	M22520/5-45 (A) (.231 Hex)