

21-33384-111 (PIN)
21-33385-111 (SOCKET)

21-33384-111 (PIN)
21-33385-111 (SOCKET)

Contact, Pin and Socket, Quadrax, Type M38999 Series I & III Special, Size 8
 Installation Instructions

See table on reverse side for quadrax cable recommended, tool selector settings, crimping tool, positioner and insertion/removal tool information.

- A 1. Cut cable for assembly of quadrax contacts.
 Note: Contact assemblies of opposite gender should be assembled at cable junction adjacent ends, to have inner wire conductors in correct orientation during contact assembly. Crossing of inner wires from their natural lie position is not permissible.
- B 1. Rubber end first, slide piggyback grommet seal back over cable jacket (not illustrated).
2. Strip cable jacket and outer braid to expose cable inner braid as illustrated. Ends must be cut cleanly and at right angles to the axial plane of the cable. Cable must not be deformed while making cuts.
- C 1. Slide crimp bushing, large diameter end first, over cable inner braid until cable jacket butts inside shoulder of crimp bushing.
- D 1. Flair cable inner braid back over crimp bushing as illustrated to expose inner wires. Trim excess cable inner braid.
2. Cut off any inner wraps or cable fillers as close to inner cable braid as possible.
3. Cut inner wires to dimension shown. All wires must be cut to equal length. It may be helpful to cut one wire to length. Then, one at a time, cut remaining wires to equal length as the first wire.
- E 1. Strip inner wires to expose center conductors as illustrated. All wires must be stripped to equal length.
- F 1. Carefully splay inner wires perpendicular to the axis of the cable as illustrated.
2. Assemble inner contact over cable center conductor until fully seated against inner wire insulation. Observe center conductor through the contact's wire inspection hole, to make certain conductor is properly positioned.
3. Crimp inner contact to center conductor using crimp tools listed in table on back. Repeat steps F2 and F3 until all inner contacts are crimped.
- G 1. Position rear insulator against inner cable braid as illustrated. Make certain insulator slots are aligned with splayed inner contact wires. One-by-one, position wired inner contacts inside the insulator slots as shown. The inner contact's retention shoulder must be positioned in front of the insulator's front surface as illustrated.

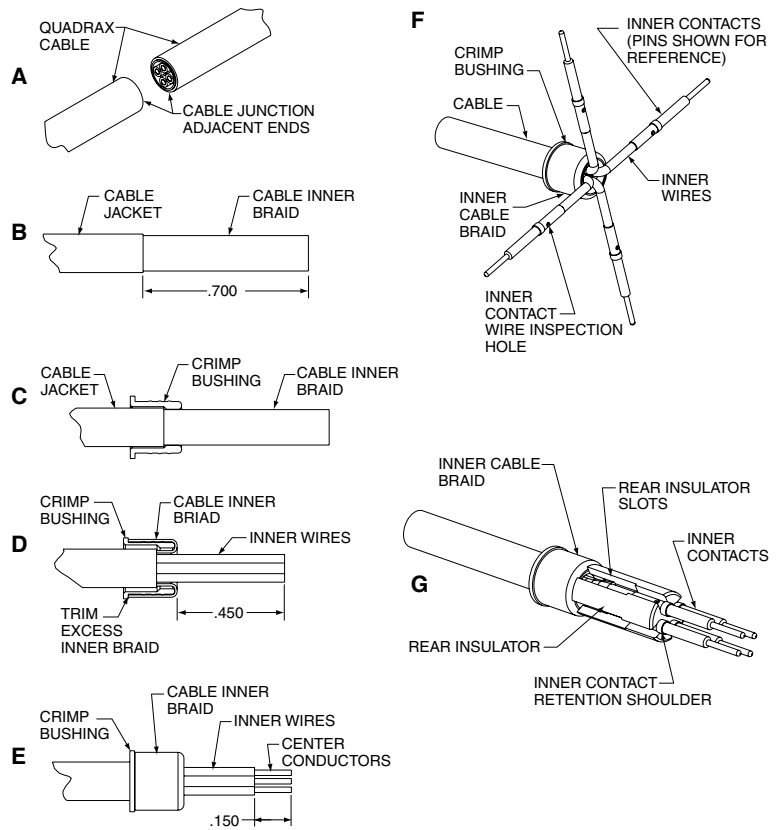

Continued on back

L-2119-AK
 April 2014

FSCM77820

21-33384-111 (PIN)
21-33385-111 (SOCKET)

- H 1. With inner contacts positioned inside rear insulator slots, assemble front insulator over the inner contacts as shown. The front insulator must butt the rear insulator, and inner contact retention shoulders must enter front insulator bores.
2. Observe the front insulator's keyway. When the inner pin assembly is held in the vertical position (with inner pin contacts on top), the inner pin contact with the insulator keyway to its right will be positioned adjacent to and in alignment with the outer contact's orientation key (for inner socket contacts, the insulator keyway should be positioned to the left of the inner socket desired adjacent to and in alignment with the outer contact's orientation key).
- I 1. Align front insulator keyway with the outer contact's rivet key. Slide the inner contact assembly inside the outer contact body until fully seated. Observe the mating end of the assembly to make certain one pair of inner contacts are in vertical alignment with the outer contact's orientation key.
2. Crimp outer contact body in the area indicated using crimp tools listed in table below.

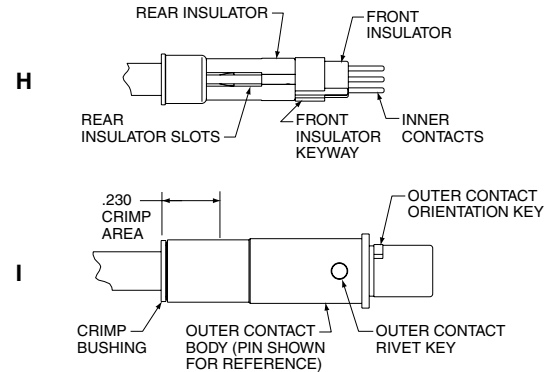

Amphenol Part Number	Description	Quadrax Cable Recommended	Inner Crimp Tools		Outer Crimp Tools	
			Tool (Setting)	Positioner	Tool	Die Set (Location)
21-33384-111	Quadrax Pin	JSFY18-1 and RCN8487-1 (110 Ohm)	M22520/2-01 (4)	Daniels K709 (M22520/2-37)	M22520/5-01	Daniels Y1999 (A) or M22520/5-45 (A)
21-33385-111	Quadrax Socket					

Contact Insertion into Connector

Contacts are inserted by hand. Insert the contact assembly into the proper rear grommet hole. Contact must be aligned with hole and not inserted at an angle. The contact's orientation key must be in vertical alignment with the connector's main key or keyway (holding contact key and connector key/keyway at "12 o'clock" orientation position is recommended). Push forward until contact is felt to snap into position within the insert. Contact may need to be slightly rotated to properly align contact orientation key with connector insert keyway. Gently tug on cable to assure retention. Slide piggyback grommet seal into position inside the connector grommet and over the crimped end of the contact.

Contact Removal from Connector

Remove piggyback grommet seal from the connector grommet. Position removal tool part number MIL-I-81969/14-12, Daniels DRK-264-8, around cable and slide tool toward connector until tool tips enter rear grommet and comes to a positive stop on the contact. Grip cable and simultaneously remove tool, contact and cable.

Amphenol

Amphenol Aerospace
 40-60 Delaware Avenue
 Sidney, New York 13838-1395
 Website: www.amphenol-aerospace.com