

21-33833-141 (RECEPTACLE)

Transition Adapter, Differential Twinax
Type High Speed, to Board,
Installation Instructions

See table on reverse side for twinax cable recommended, tool selector settings, crimping tool and positioner information.

- A 1. Cut cable for assembly of transition adapter.
- B 1. Strip cable jacket to expose cable outer braid as illustrated. Ends must be cut cleanly and at right angles to the axial plane of the cable. Cable must not be deformed while making cuts.
- C 1. Slide crimp bushing, large diameter end first, over cable braid until cable jacket butts inside shoulder of crimp bushing.
- D 1. Flair cable braid back over crimp bushing as illustrated to expose inner wires. Trim excess cable braid.
2. Cut off any inner braids, wraps or cable fillers as close to outer cable braid as possible.
3. Cut inner wires to dimension shown. All wire must be cut to equal length. It may be helpful to cut one wire to length. Then, cut remaining wire to equal length as the first wire.
- E 1. Strip inner wires to expose center conductors as illustrated. All wires must be stripped to equal length.
- F 1. Carefully splay inner wires perpendicular to the axis of the cable as illustrated.
2. Assemble inner contact over cable center conductor until fully seated against inner wire insulation. Observe center conductor through the contact's wire inspection hole, to make certain conductor is properly positioned.
3. Crimp inner contact to center conductor using crimp tools listed in table on back. Repeat steps F2 and F3 until all inner contacts are crimped.
- G 1. Position rear insulator against cable braid as illustrated. Make certain insulator slots are aligned with splayed inner contact wires. One-by-one, position wired inner contacts inside the insulator slots as shown. The inner contact's retention shoulder must be positioned in front of the insulator's front surface as illustrated.

Continued on back

L-2119-BU
April 2008

FSCM77820

21-33833-141 (RECEPTACLE)

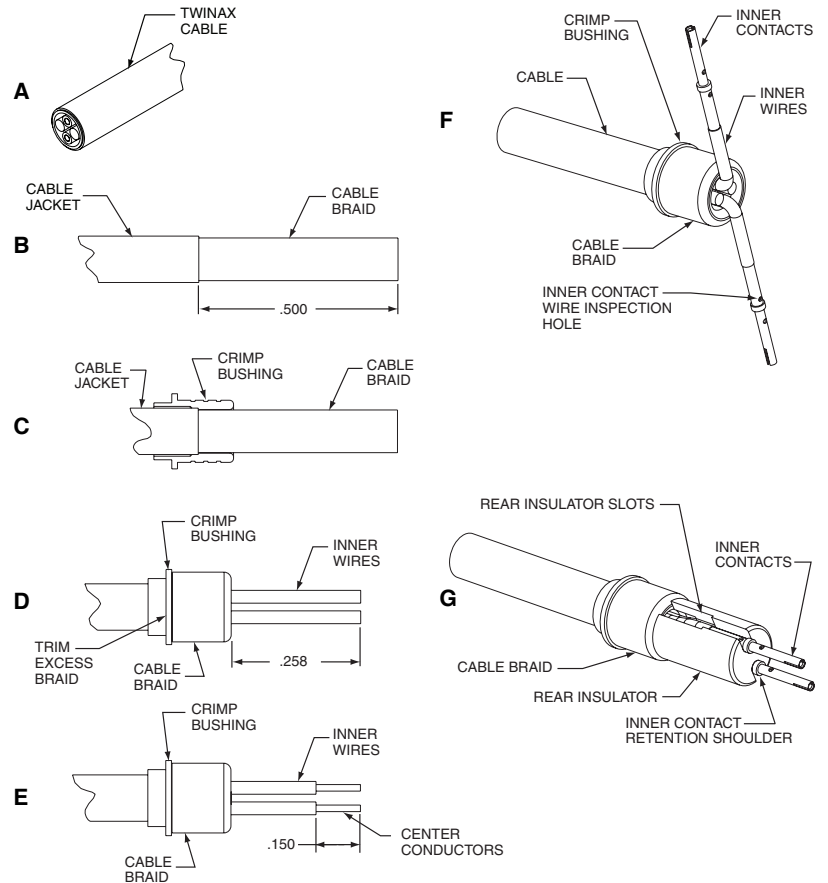

21-33833-141 (RECEPTACLE)

- H
1. With inner contacts positioned inside rear insulator slots, assemble front insulator over the inner contacts as shown. The front insulator must butt the rear insulator, and inner contact shoulders must enter front insulator bores.
 2. Observe the front insulator keyway. When the inner assembly is held in the vertical position (with inner socket contacts on top), the inner socket contact with the insulator keyway to its right will be engaged with the S1 inner PCB contact shown in View I.
- I
1. Align front insulator keyway with the outer contact's rivet key. Slide the inner contact assembly inside the outer contact assembly until fully seated.
 2. Crimp outer contact body in the area indicated using crimp tools listed in table below.

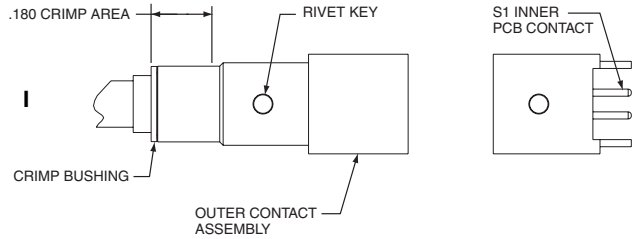
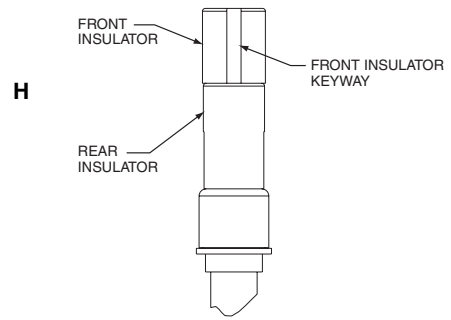

Amphenol Part Number	Description	Twinax Cable Recommended	Inner Crimp Tools		Outer Crimp Tools	
			Tool (Setting)	Positioner	Tool	Die Set (Location)
21-33833-141	Differential Twinax Transition Adapter (100 Ohm)	Tensolite 24463/9P025X-2 (100 Ohm)	M22520/2-01 (4)	M22520/2-34	M22520/5-01	M22520/5-45 (A)

Amphenol

Amphenol Aerospace
 40-60 Delaware Avenue
 Sidney, New York 13838-1395
 Website: www.amphenol-aerospace.com