

21-033836-081 (PLUG)

Transition Adapter, Plug, Quadrax
Type High Speed, to Board,
Installation Instructions

See table on reverse side for quadrax cable recommended and crimping tool information.

- A 1. Cut cable for assembly of transition adapter plug.
- B 1. Strip cable jacket to expose cable outer braid as illustrated. Ends must be cut cleanly and at right angles to the axial plane of the cable. Cable must not be deformed while making cuts.
- C 1. Slide crimp bushing, large diameter end first, over cable braid until front is flush with jacket cut edge. Secure in place with a piece of tape that can be removed later
- D 1. Flair cable braid back over crimp bushing as illustrated to expose inner wires. Trim excess cable braid.
 - 2. Cut off any inner braids, wraps or cable fillers as close to outer cable braid as possible.
 - 3. Cut inner wires to dimension shown. All wires must be cut to equal length. It may be helpful to cut one wire to length. Then, one at a time, cut remaining wires to equal length as the first wire.
- E 1. Strip inner wires to expose center conductors as illustrated. All wires must be stripped to equal length.
- F 1. Carefully splay inner wires perpendicular to the axis of the cable as illustrated.
 - 2. Assemble inner contact over cable center conductor until fully seated against inner wire insulation. Observe center conductor through the contact's wire inspection hole, to make certain conductor is properly positioned.
 - 3. Crimp inner contact to center conductor using crimp tools listed in table on back. Repeat steps F2 and F3 until all inner contacts are crimped.
- G 1. Position rear insulator against cable braid as illustrated. Make certain insulator slots are aligned with splayed inner contact wires. One-by-one, position wired inner contacts inside the

21-033836-081 (PLUG)

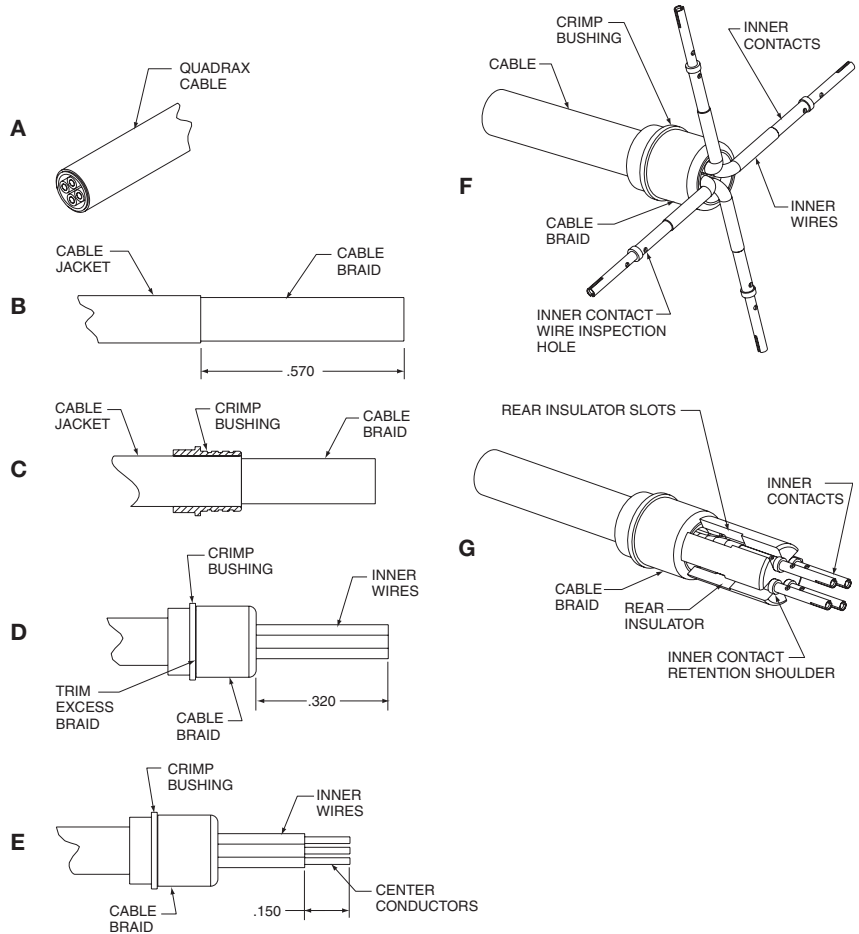

Continued on back

L-2119-CE
August 2016

FSCM77820

21-033836-081 (PLUG)

insulator slots as shown. The inner contact's retention shoulder must be positioned in front of the insulator's front surface as illustrated.

- H 1. With inner contacts positioned inside rear insulator slots, assemble front insulator over the inner contacts as shown. The front insulator must butt the inner contact retention shoulders.
 - 2. Observe the front insulator's keyway. When the inner assembly is held in the vertical position (with inner socket contacts on top), the inner socket contact with the insulator keyway to its left will be positioned at the S1 inner contact position shown in View I.

NOTE: As of December 01, 2011 Amphenol has changed its recommended internal contact numbering scheme for Transition Adapter Plugs to increase consistency across the quadrax product line. Physical wiring remains the same, the only change is the numbering scheme. Care should be taken to confirm system wiring is correct.
- I 1. Align front insulator keyway with the outer contact's rivet key indicator. Slide the inner contact assembly inside the outer contact assembly until fully seated. Observe the mating end of the assembly to make certain contacts are aligned as shown (Ref 45 degrees).
 - 2. Crimp outer contact body in the area indicated using crimp tools listed in table below. (Remove tape used to hold crimp bushing in position on cable during assembly.)

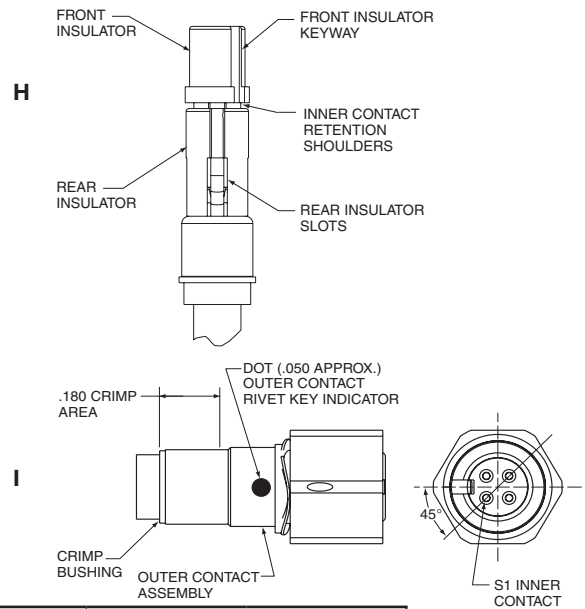

Amphenol Part Number	Description	Twinax Cable Recommended	Inner Crimp Tools		Outer Crimp Tools	
			Tool (Setting)	Positioner	Tool	Die Set (Location)
21-033836-081	Quadrax Transition Adapter Plug (100 Ohm)	W. L. Gore RCN8647 (110 Ohm)	M22520/2-01 (5)	M22520/2-37 (Daniels K709)	M22520/5-01	M22520/5-45 (A)

Amphenol

Amphenol Aerospace
40-60 Delaware Avenue
Sidney, New York 13838-1395
Website: www.amphenol-aerospace.com

21-033836-081 (PLUG)

Transition Adapter, Plug, Quadrax
Type High Speed, to Board,
Installation Instructions

See table on reverse side for quadrax cable recommended and crimping tool information.

- A 1. Cut cable for assembly of transition adapter plug.
- B 1. Strip cable jacket to expose cable outer braid as illustrated. Ends must be cut cleanly and at right angles to the axial plane of the cable. Cable must not be deformed while making cuts.
- C 1. Slide crimp bushing, large diameter end first, over cable braid until front is flush with jacket cut edge. Secure in place with a piece of tape that can be removed later
- D 1. Flair cable braid back over crimp bushing as illustrated to expose inner wires. Trim excess cable braid.
 2. Cut off any inner braids, wraps or cable fillers as close to outer cable braid as possible.
 3. Cut inner wires to dimension shown. All wires must be cut to equal length. It may be helpful to cut one wire to length. Then, one at a time, cut remaining wires to equal length as the first wire.
- E 1. Strip inner wires to expose center conductors as illustrated. All wires must be stripped to equal length.
- F 1. Carefully splay inner wires perpendicular to the axis of the cable as illustrated.
 2. Assemble inner contact over cable center conductor until fully seated against inner wire insulation. Observe center conductor through the contact's wire inspection hole, to make certain conductor is properly positioned.
 3. Crimp inner contact to center conductor using crimp tools listed in table on back. Repeat steps F2 and F3 until all inner contacts are crimped.
- G 1. Position rear insulator against cable braid as illustrated. Make certain insulator slots are aligned with splayed inner contact wires. One-by-one, position wired inner contacts inside the

21-033836-081 (PLUG)

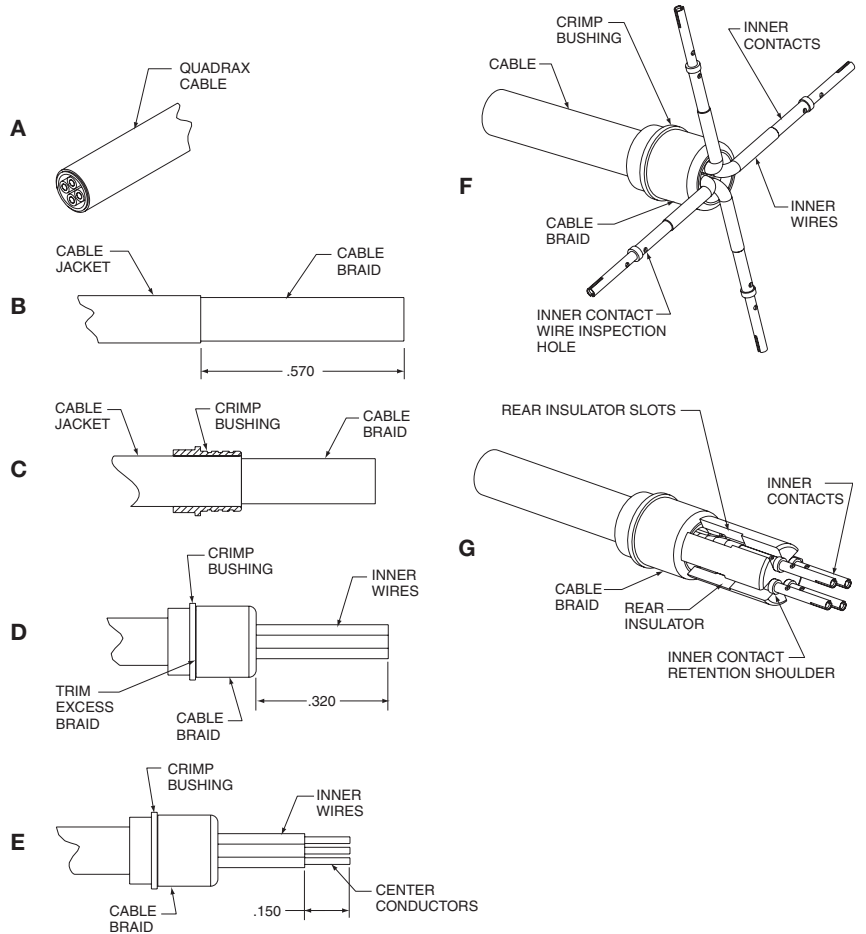

Continued on back

L-2119-CE
August 2016

FSCM77820

Amphenol Aerospace
40-60 Delaware Avenue
Sydney, New York 13838-1395
Website: www.amphenol-aerospace.com

Amphenol Part Number	Description	Twinned Cable Recommended	Inner Crimp Tools		Outer Crimp Tools	
			Tool (Setting)	Positioner	Tool	Die Set (Location)
21-033836-081	Quadrax Transition Adapter Plug (100 Ohm)	W. L. Gore RCN8647 (110 Ohm)	M22520/2-01 (S)	M22520/2-37 (Daniels K709)	M22520/5-01	M22520/5-45 (A)

1. Align front insulator keyway with the outer contact's rivet key in- ing is correct.
 - 1.1. Observe the front insulator's keyway. When the inner assembly is held in the vertical position (with inner socket contacts on top), the inner socket contact with the insulator keyway to its left will be positioned at the S1 inner contact position shown in View 1. NOTE: As of December 01, 2011 Amphenol has changed its recommended internal contact numbering scheme for Transition Adapter Plugs to increase consistency across the quadrax product line. Physical wiring remains the same, the only change is the numbering scheme. Care should be taken to confirm system wiring is correct.
2. Crimp outer contact body in the area indicated using crimp tools listed in table below. (Remove tape used to hold crimp bushing in position on cable during assembly.)

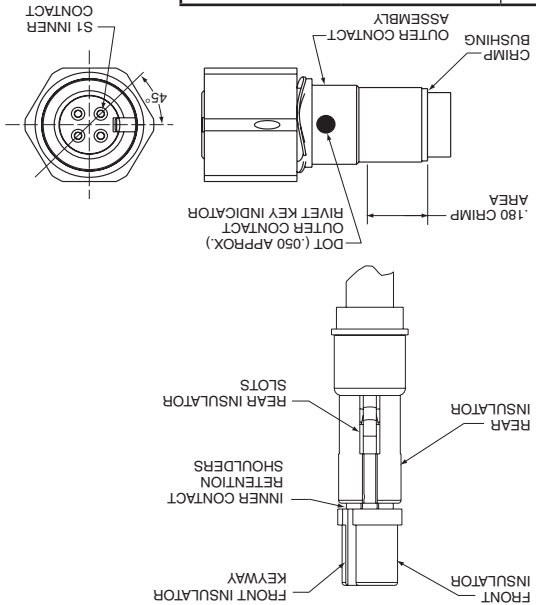

21-033836-081 (PLUG)