

21-033378-051 (PIN)
21-033379-051 (SOCKET)

Contact, Pin and Socket, Differential Twinax, Type ARINC 600 Special, Size 8
 Installation Instructions

See table on reverse side for twinax cable recommended, tool selector settings, crimping tool, positioner and insertion/removal tool information.

- A** 1. Cut cable for assembly of differential twinax contacts.
- B** 1. If applicable, slide piggyback grommet seal, rubber end first, back over cable jacket (not illustrated).
2. Strip cable jacket to expose cable outer braid as illustrated. Ends must be cut cleanly and at right angles to the axial plane of the cable. Cable must not be deformed while making cuts.
- C** 1. Slide crimp bushing, large diameter end first, over cable braid until cable jacket butts inside shoulder of crimp bushing.
- D** 1. Flair cable braid back over crimp bushing as illustrated to expose inner wires. Trim excess cable braid.
2. Cut off any inner braids, wraps or cable fillers as close to outer cable braid as possible.
3. Cut inner wires to dimension shown. All wires must be cut to equal length. It may be helpful to cut one wire to length, then cut remaining wire to equal length as the first wire.
- E** 1. Strip inner wires to expose center conductors as illustrated. All wires must be stripped to equal length.
- F** 1. Carefully splay inner wires perpendicular to the axis of the cable as illustrated.
2. Assemble inner contact over cable center conductor until fully seated against inner wire insulation. Observe center conductor through the contact's wire inspection hole, to make certain conductor is properly positioned.
3. Crimp inner contact to center conductor using crimp tools listed in table on back. Repeat steps F2 and F3 until all inner contacts are crimped.
- G** 1. Position rear insulator against cable braid as illustrated. Make certain insulator slots are aligned with splayed inner contact wires. One-by-one, position wired inner contacts inside the insulator slots as shown. The inner contact's retention shoulder must be positioned in front of the insulator's front surface as illustrated. (Two of the rear insulator slots will not be used).
- H** 1. With inner contacts positioned inside rear insulator slots, assemble front insulator over the inner contacts as shown. The front insulator must butt the rear insulator, and inner contact retention shoulders must enter front insulator bores.

Continued on back

L-2119-DG
April 2011

FSCM77820

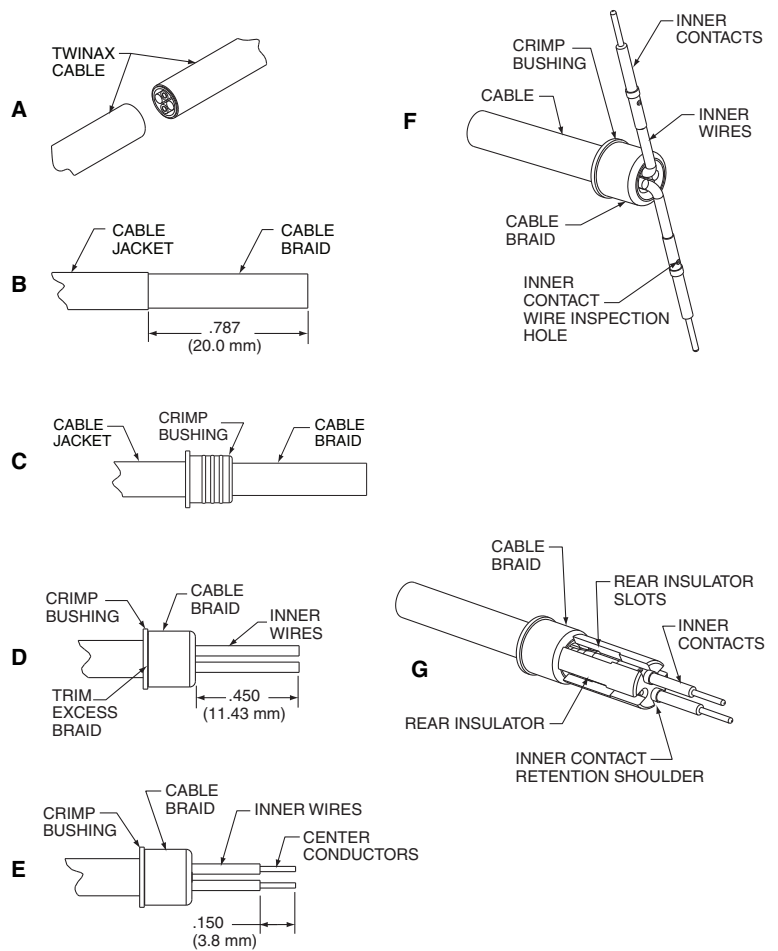

21-033378-051 (PIN)
21-033379-051 (SOCKET)

2. Observe the front insulator's keyway. When the inner pin assembly is held in the vertical position (with inner pin contacts on top), the inner pin contact with the insulator keyway to its left will be positioned at the "9 o'clock" orientation position, when viewing the pin assembly from the mating end. (For inner socket contacts, the insulator keyway should be positioned to the right of the inner socket desired at the mating "3 o'clock" orientation position, when viewing the socket assembly from the mating end).
- I
1. Align front insulator keyway with the outer contact's rivet key. Slide the inner contact assembly inside the outer contact body until fully seated. Observe the mating end of the assembly to make certain the inner contacts are at the "3 o'clock" and "9 o'clock" orientation positions, when the outer contact's orientation key is held at the "12 o'clock" position.
 2. Crimp outer contact body in the area indicated using crimp tools listed in table below.

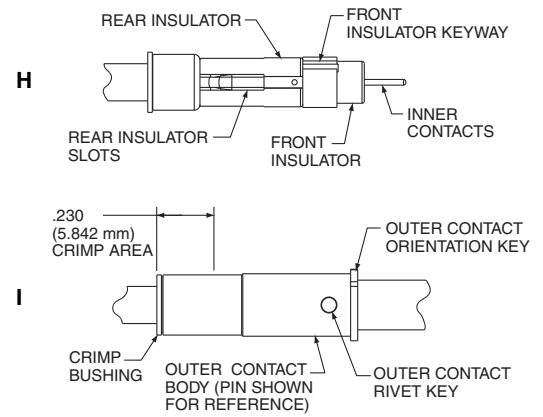

Amphenol Part Number	Twinax Cable Recommended	Description	Inner Crimp Tools		Outer Crimp Tools	
			Tool (Setting)	Positioner	Tool	Die Set (Location)
21-033378-051	Tensolite 24463/9P025X-2(LD) (100 Ohm)	Differential Twinax Pin	M22520/2-01 (5)	Daniels K709 (M22520/2-37)	M22520/5-01	M22520/5-45 (B)
21-033379-051		Differential Twinax Socket				

Contact Insertion into Connector

Contacts are inserted by hand. Insert the contact assembly into the proper rear grommet hole. Contact must be aligned with hole and not inserted at an angle. The contact's orientation key must be aligned with the connector insert cavity keyway. Push forward until contact is felt to snap into position within the insert. Contact may need to be slightly rotated to properly align contact orientation key with connector insert cavity keyway. Gently tug on cable to assure retention. If applicable, slide piggyback grommet seal into position inside the connector grommet and over the crimped end of the contact.

Contact Removal from Connector

If applicable, remove piggyback grommet seal from the connector grommet. Position removal tool part number MIL-I-81969/14-12, Daniels DRK-264-8, around cable and slide tool toward connector until tool tips enter rear grommet and comes to a positive stop on the contact. Grip cable and simultaneously remove tool, contact and cable.

Amphenol

Amphenol Aerospace
 40-60 Delaware Avenue
 Sidney, New York 13838-1395
 Website: www.amphenol-aerospace.com