

21-032904-031 (PIN)
21-032905-031 (SOCKET)

Contact, Pin and Socket, Octonet
 Type M38999 Series I & III, Size 8 Installation Instructions

See table for 4 pair cable recommended, crimp tool settings, crimping tools, positioners and insertion/removal tool information.

- A** 1. Cut cable for assembly of octonet contacts.
 Note: Contact assemblies of opposite gender should be assembled at cable junction adjacent ends, to have inner wire pairs in correct orientation during contact assembly. Crossing of inner wire pairs from their natural position is not permissible.
- B** 1. Slide heat shrink tubing back over cable jacket (not illustrated).
 2. With a razor or scalpel, slit and flair open cable jacket end (.500 approx length)
- C** 1. Using a needle nose pleyer or stub tip of wire stripper, grab cable jacket slit end corner and pull jacket back over itself until 2,000 of cable polyimide binder wrap is exposed.
 2. Unravel and cut away polyimide binder wrap as close to cable jacket edge as possible.
 3. Unravel and cut away PTFE binder wrap as close to cable jacket edge as possible. To expose cable braid.
 4. Trim away entire exposed cable bundle end to 1.800 dimension shown.
 5. Fold cable braid firmly back over cable jacket to expose inner wire pair bundle.
 6. Unravel and cut away PTFE binder wrap as close to cable braid edge as possible.
 7. Trim away entire end of inner wire pair bundle .300 as shown.
- D** 1. Carefully splay wire pairs 45° approx to axis of cable (do not unravel wire pair foil shield)
 2. Trim cable center filler as close to cable braid as possible.
 3. Wrap each wire pair foil shield with foil tape as close to cable braid as possible, using 3M 3313 copper foil tape (.250 wide x 3 mil thk - 1.4 foil + 1.6 adhesive). Use tape sparingly to avoid build-up. (1 complete wrap with small overlap).
- E** 1. Carefully trim each wire pair foil shield to front edge of foil tape, to expose cable inner wires (8) as shown.
 2. Carefully trim away cable fillers of each wire pair as close to edge of foil tape as possible.

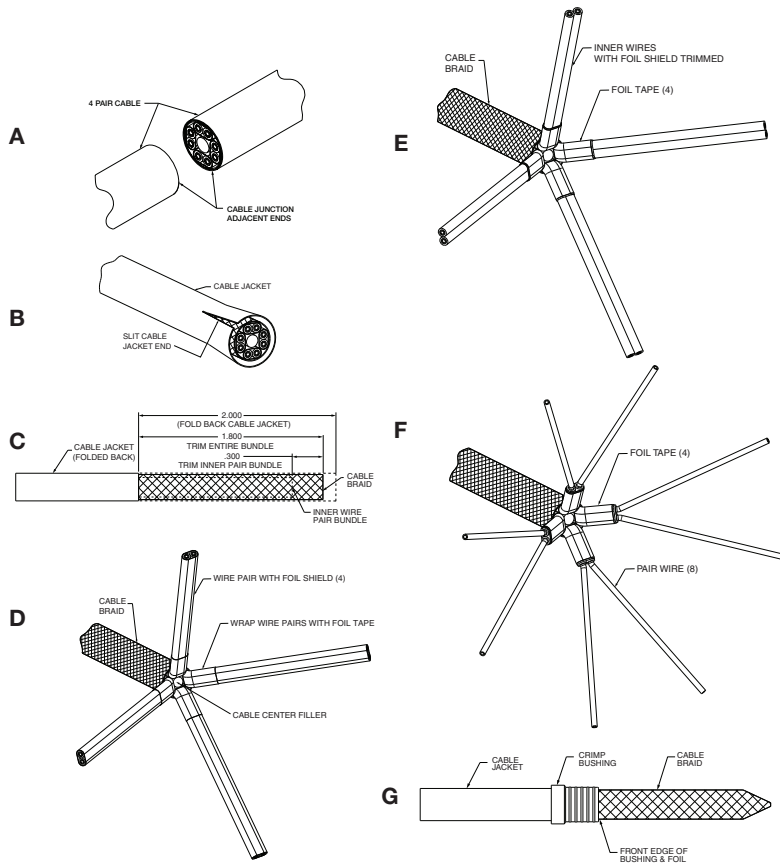

L-2119-GD
 February 2017

FSCM77820

21-032904-031 (PIN)
21-032905-031 (SOCKET)

- F** 1. Carefully untwist, spread & straighten pair wires (Do not disturb foil tape wrap).
- G** 1. Carefully fold cable inner wires back to center axis of cable (Do not disturb foil tape wrap).
 2. Firmly fold cable braid forward over inner wires and twist together cable braid strand ends to form point as shown.
 3. Slide crimp bushing, large diameter end first, over cable braid until front edge of bushing is approximately even with front edge of foil tape wrap (under braid).
 4. Wrap large diameter end of bushing & cable jacket with tape to maintain position of the bushing (Can be removed prior to crimping contact outer body & bushing).
- H** 1. Firmly fold cable braid back over crimp bushing and firmly wrap excess cable braid around cable jacket (not illustrated).
 2. Splay cable inner wire pairs perpendicular to the axis of the cable.
 3. Carefully untwist cable inner wire pairs until they lay straight and untwisted as illustrated.
- I** 1. Splayed inner wire pairs should match one of the illustrated wire color patterns shown. If not, grasp any non-conforming wire pair/s and untwist 180° (as close to bushing edge as possible) to match the illustrated wire color pattern. Note, the mating contact should be assembled to a cable junction end matching the mirrored image of the wire color pattern used.
- J** 1. Assemble 4 inner wire pairs through 4 oval holes of shield extension (large diameter end of shield first) until shield extension butts against cable braid. The inner wire pair color pattern of view i must be maintained by inner wire pairs exiting shield extension holes. (suggested assembly procedure: insert 1 wire pair at a time partially through shield extension holes. After all wire pairs are partially inserted, push shield extension rearward until butted against cable braid and all inner wires are fully extended through shield extension holes).
- K** 1. Check to make certain the inner wire pair color pattern of view i was maintained by inner wire pairs exiting shield extension.
 2. Cut all inner wires to .355 length dimension shown (cutting inner wires simultaneously is recommended). All wires must be cut to equal length.
- L** 1. Splay inner wire pairs firmly back over shield extension as shown, leaving one wire extended.
 2. Strip extended inner wire insulation .115 to expose inner conductor as shown.

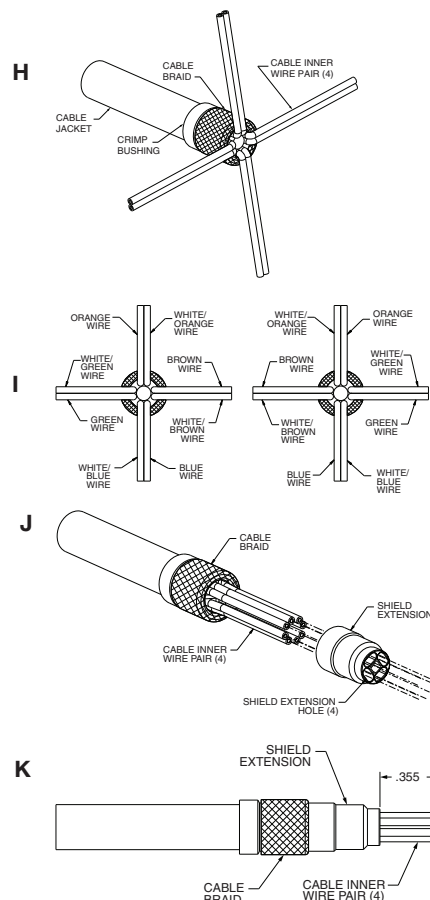

Amphenol

Amphenol Aerospace
 40-60 Delaware Avenue
 Sidney, New York 13838-1395
 Website: www.amphenol-aerospace.com

21-032904-031 (PIN)

21-032905-031 (SOCKET)

- M**
1. Assemble inner contact over cable center conductor until fully seated against inner wire insulation. Observe center conductor through contact's wire inspection hole, to make certain conductor is properly positioned.
 2. Crimp inner contact to center conductor using tools listed in table (make certain contact is seated firmly against wire insulation before crimping).
 3. Splay crimped contact and wire back over shield extension and extend second inner wire of wire pair.
 4. Repeat stripping of wire insulation per step L2.
 5. Repeat crimping of inner contact per steps M1 and M2.
 6. Splay crimped contact and wire back over shield extension and extend another inner wire.
 7. Repeat stripping of wire insulation and crimping of inner contacts per step L2 through M6 until all inner contacts are crimped (8 total).
- N**
1. Assemble rear insulator assembly key into shield extension keyway until rear insulator's back surface butts against shield extension's front surface (this will result in rear insulator slots being properly aligned with corresponding splayed inner contact/wire pairs).
- O**
1. One-by-one, assemble wired inner contacts into rear insulator slots until fully seated as shown. Inner contact's retention undercut (shown in view N) must be positioned to capture rear insulator's retention shoulder (shown in view N), before fully seating inner contact. When contacts are properly seated, inner contact's retention shoulder will be positioned in front of rear insulator's front surface as shown. It is recommended that the two inner contacts of a wire pairs be assembled into insert slots consecutively, followed by assembly of the two inner contacts from the opposing wire pair.
- P**
1. Assemble front insulator assembly over inner contacts until rear surface of front insulator butts retention shoulder of inner contacts as shown. The front insulator keyway must be centrally aligned with the contact pair desired at contact positions 1 & 2 (shown in mating face view).
 2. Cut away excess cable braid (trim to crimp bushing shoulder as shown).
- Q**
1. Align front insulator keyway (shown in view P) with outer contact's rivet key. Slide inner contact assembly inside outer contact assembly until fully seated. Observe contact's mating end to make certain inner contacts are aligned as shown in mating face view.
 2. Crimp outer contact body and crimp bushing in area shown using tools listed in table.
 3. Position shrink tube over outer contact body as shown. Tube must not cover integrated removal tool. Shrink tubing in place to provide rear end sealing. For improved sealing, apply adhesive to outside rear surface of outer contact body prior to shrinking tubing.

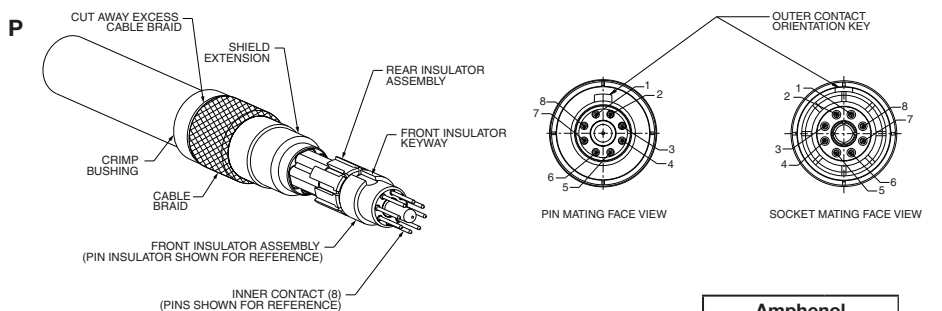
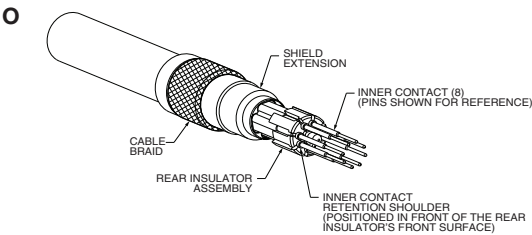
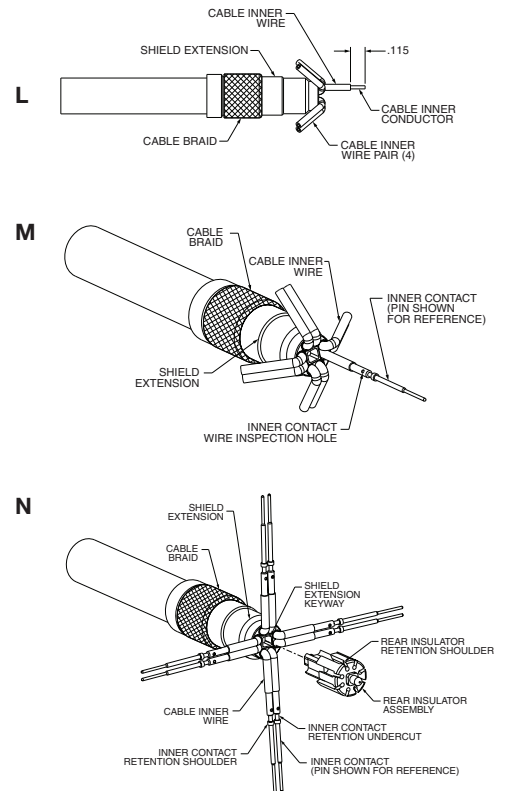

Amphenol Suggested Wiring	
Differential Pair	Inner ID
1	1
	2
2	3
	4
3	5
	6
4	7
	8

Amphenol Part Number	Description	4 Pair Quadrx Cable Recommended	Inner Crimp Tools		Outer Crimp Tools	
			Tool (Setting)	Positioner	Tool	Die Set
21-032904-031	Octonet Pin (100 Ohm)	W.L. Gore GSC-03-84043-01	M22520/2-01 (2)	Daniels K1958	M22520/5-01	Daniels Y2039
21-032905-031	Octonet Socket (100 Ohm)					

Contact Insertion into Connector
 Contacts are inserted by hand. Insert the contact assembly into the proper rear grommet hole. Contact must be aligned with hole and not inserted at an angle. The contact's orientation key must be in vertical alignment with the connector's main key or keyway (holding contact key and connector key/keyway at "12 o'clock" orientation position is recommended). Push forward until contact is felt to snap into position within the insert. Contact may need to be slightly rotated to properly align contact orientation key with connector insert keyway. Gently tug on cable to assure retention.

Contact Removal from Connector
 Slide integrated removal tool toward connector until tool comes to a positive stop on the contact. Grip cable and simultaneously remove contact and cable.

Amphenol

Amphenol Aerospace
 40-60 Delaware Avenue
 Sidney, New York 13838-1395
 Website: www.amphenol-aerospace.com