

**21-032904-061 (PIN)**  
**21-032905-061 (SOCKET)**

Contact, Pin and Socket, 4 Pair Quadrax,  
 Type M38999 Series I & III, Size 8, Installation Instructions

See table for 4 pair quadrax cable recommended, crimp tool settings, crimping tools, positioner and insertion/removal tool information.

- A** 1. Cut cable for assembly of 4 pair quadrax contacts.  
 Note: Contact assemblies of opposite gender should be assembled at cable junction adjacent ends, to have inner wire pairs in correct orientation during contact assembly. Crossing of inner wire pairs from their natural position is not permissible.
- B** 1. Slide heat shrink tubing back over cable jacket (not illustrated).  
 2. Strip cable jacket 1.800 to expose cable outer braid as illustrated. Ends must be cut cleanly and at right angles to the axial plane of the cable. Cable must not be deformed while making cuts.  
 3. Fold cable braid firmly back over cable jacket.  
 4. Cut away entire end of inner cable bundle .300 as shown.  
 5. Unravel and cut away inner PTFE binder wrap as close to cable jacket edge as possible.
- C** 1. Firmly fold cable braid forward over inner cable bundle and twist together cable braid strand ends to form point as shown.  
 2. Slide crimp bushing, large diameter end first, over cable braid until cable jacket butts inside shoulder of crimp bushing.
- D** 1. Firmly fold cable braid back over crimp bushing and firmly wrap excess cable braid around cable jacket (not illustrated) to hold crimp bushing in position during assembly of subsequent contact components.  
 2. Splay cable inner wire pairs perpendicular to the axis of the cable  
 3. Cut away cable center filler as close to crimp bushing edge as possible.  
 4. Carefully untwist cable inner wire pairs until they lay straight and untwisted as illustrated (A flat nose pliers can be used to untwist the wire pairs. Use caution not to distort wire insulation. Start untwisting the wire pairs at the crimp bushing, then untwist and straighten each succeeding wire twist until end of wire pair is reached).
- E** 1. Splayed inner wire pairs should match one of the illustrated wire color patterns shown. If not, grasp any non-conforming wire pair/s and untwist 180° (As close to bushing edge as possible) to match the illustrated wire color pattern. Note, the mating contact should be assembled to a cable junction end matching the mirrored image of the wire color pattern used for this assembly.

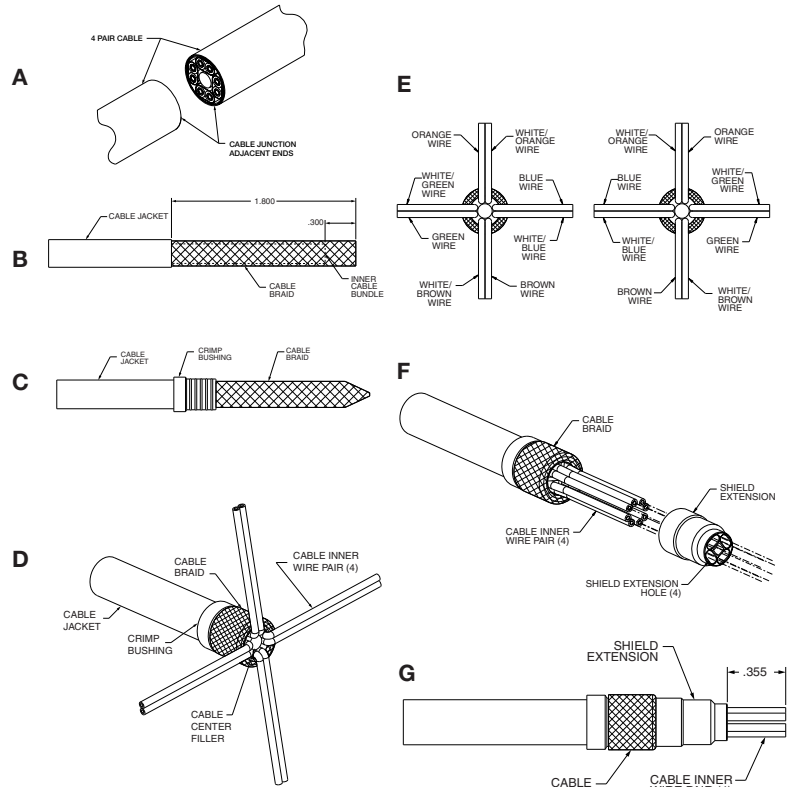

**L-2119-HF**  
**February 2019**

**FSCM77820**

**21-032904-061 (PIN)**  
**21-032905-061 (SOCKET)**

- F** 1. Assemble 4 inner wire pairs through 4 oval holes of shield extension (Large diameter end of shield first) until shield extension butts against cable braid. The inner wire pair color pattern of view E must be maintained by inner wire pairs exiting shield extension. (Suggested assembly procedure: insert 1 wire pair at a time partially through shield extension holes. After all wire pairs are partially inserted, push shield extension rearward until butted against cable braid and all inner wires are fully extended through shield extension holes)
- G** 1. Check to make certain the inner wire pair color pattern of view E was maintained by inner wire pairs exiting shield extension.  
 2. Cut all inner wires to .355 length dimension shown (Cutting inner wires simultaneously is recommended). All wires must be cut to equal length.
- H** 1. Splay inner wire pairs firmly back over shield extension as shown, leaving one wire pair extended.  
 2. Separate the wires of the extended wire pair by carefully slitting the insulation attachment seam. When splitting the attachment seam, use caution not to penetrate with wire insulation of the extended wires.  
 3. After slitting the seam, splay one of extended inner wires back over shield extension (leaving one wire extended).  
 4. Strip extended inner wire insulation .115 to expose inner conductor as shown.
- I** 1. Assemble inner contact over cable center conductor until fully seated against inner wire insulation. Observe center conductor through contact's wire inspection hole, to make certain conductor is properly positioned.  
 2. Crimp inner contact to center conductor using tools listed in table (make certain contact is seated firmly against wire insulation before crimping).  
 3. Splay crimped contact and wire back over shield extension and extend second inner wire of wire pair.  
 4. Repeat stripping of wire insulation per step H4.  
 5. Repeat crimping of inner contact per steps I1 and I2.  
 6. Splay crimped contact and wire back over shield extension and extend another inner wire pair.  
 7. Repeat slitting insulation seams, stripping of wire insulation and crimping of inner contacts per steps H2 through H6 until all inner contacts are crimped (8 total).
- J** 1. Assemble rear insulator assembly key into shield extension keyway until rear insulator's back surface butts against shield extension's front surface (this will result in rear insulator slots being properly aligned with corresponding splayed inner contact/wire pairs).

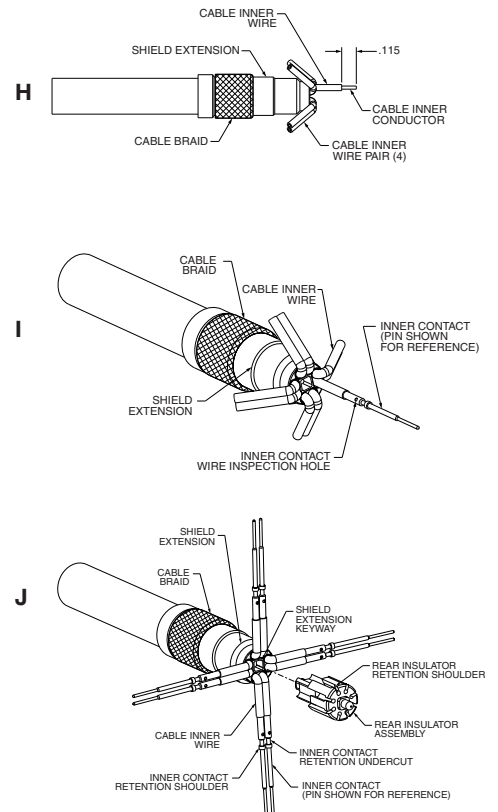

**Amphenol**

Amphenol Aerospace  
 40-60 Delaware Avenue  
 Sidney, New York 13838-1395  
 Website: www.amphenol-aerospace.com

**21-032904-061 (PIN)**  
**21-032905-061 (SOCKET)**

- K** 1. One-by-one, assemble wired inner contacts into rear insulator slots until fully seated as shown. Inner contact's retention undercut (shown in view J) must be positioned to capture rear insulator's retention shoulder (shown in view J), before fully seating inner contact. When contacts are properly seated, inner contact's retention shoulder will be positioned in front of rear insulator's front surface as shown. It is recommended that the two inner contacts of a wire pairs be assembled into insert slots consecutively, followed by assembly of the two inner contacts from the opposing wire pair.
- L** 1. Assemble front insulator assembly over inner contacts until rear surface of front insulator butts retention shoulder of inner contacts as shown. The front insulator keyway must be centrally aligned with the contact pair desired at contact positions 1 & 2 (shown in mating face view).  
 2. Cut away excess cable braid (trim to crimp bushing shoulder as shown).
- M** 1. Align front insulator keyway (shown in view L) with outer contact's rivet key. Slide inner contact assembly inside outer contact assembly until fully seated. Observe contact's mating end to make certain inner contacts are aligned as shown in mating face view.  
 2. Crimp outer contact body and crimp bushing in area shown using tools listed in table.  
 3. Position shrink tube over outer contact body as shown. Tube must not cover intergraded removal tool. Shrink tubing in place to provide rear end sealing. For improved sealing, apply adhesive to outside rear surface of outer contact body prior to shrinking tubing.

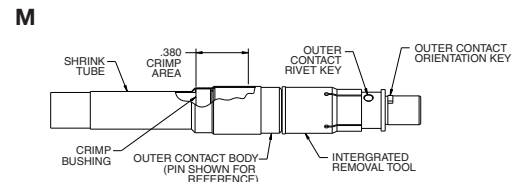
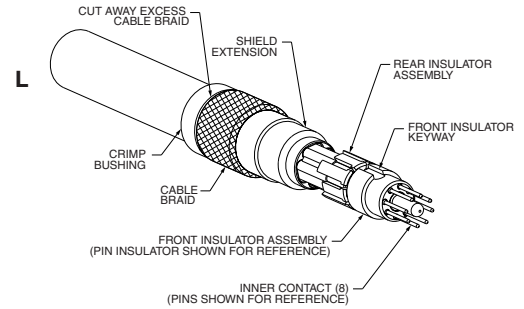
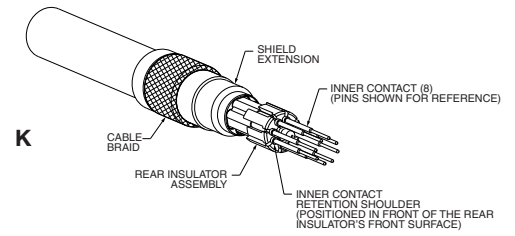

Amphenol Suggested Wiring	
Differential Pair	Inner ID
1	1
	2
2	3
	4
3	5
	6
4	7
	8

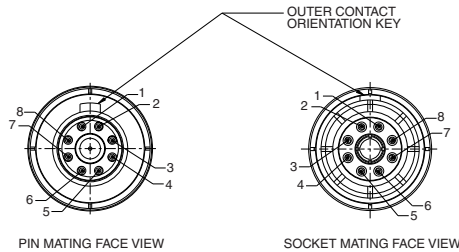

Amphenol Part Number	Description	4 Pair Quadrx Cable Recommended	Inner Crimp Tools		Outer Crimp Tools	
			Tool (Setting)	Positioner	Tool	Die Set
21-032904-061	4 Pair Quadrx Pin (100 Ohm)	Thermax MX10G-24FLX	M22520/2-01 (3)	Daniels K1958	M22520/5-01	Daniels Y2039
21-032905-061	4 Pair Quadrx Socket (100 Ohm)					

**Contact Insertion into Connector**

Contacts are inserted by hand. Insert the contact assembly into the proper rear grommet hole. Contact must be aligned with hole and not inserted at an angle. The contact's orientation key must be in vertical alignment with the connector's main key or keyway (holding contact key and connector key/keyway at "12 o'clock" orientation position is recommended). Push forward until contact is felt to snap into position within the insert. Contact may need to be slightly rotated to properly align contact orientation key with connector insert keyway. Gently tug on cable to assure retention.

**Contact Removal from Connector**

Slide integrated removal tool toward connector until tool comes to a positive stop on the contact. Grip cable and simultaneously remove contact and cable.

**Amphenol**

Amphenol Aerospace  
 40-60 Delaware Avenue  
 Sidney, New York 13838-1395  
 Website: www.amphenol-aerospace.com