

Installation Instructions
(General Insertion and Removal) for Size 12 & 16.
Power, coaxial, concentric twinax and triax terminated cables.

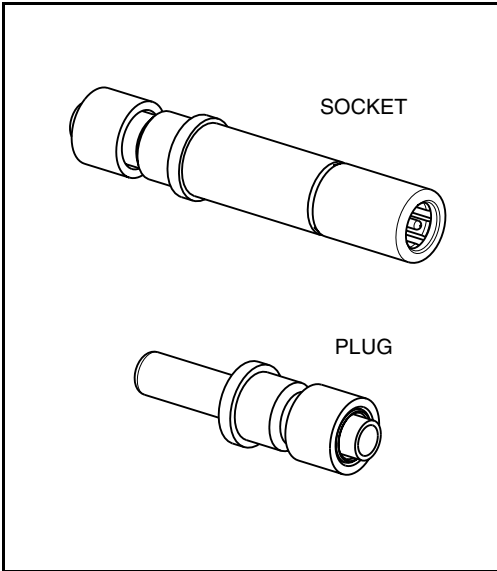

Contact/Cable Insertion into Connector

Contacts are inserted by hand. Insert the contact assembly into the proper rear grommet hole. Contact must be aligned with hole and not inserted at an angle.

STEP 1

Push forward using insertion tool (listed in table on back) until contact is felt to snap into position within the insert. While holding cable forward, remove tool.

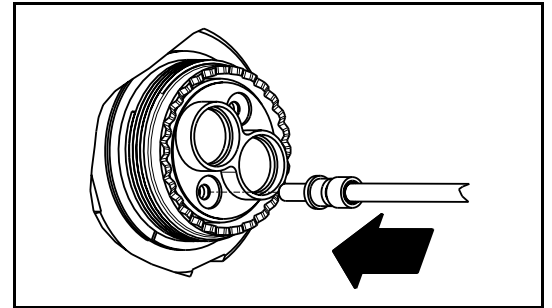

STEP 2

Gently tug on cable to assure retention.

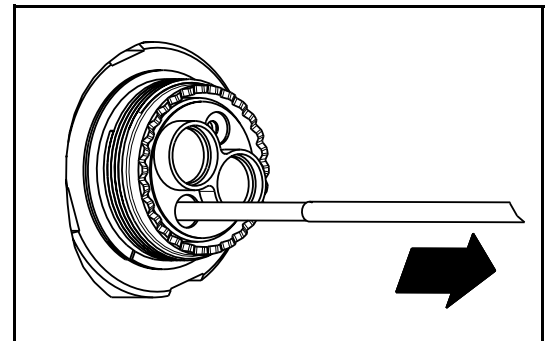

Contact/Cable Removal from Connector

Position removal tool (see table) around cable and slide tool toward connector until tool tips enter rear grommet and comes to a positive stop on the contact. Grip cable and simultaneously remove tool, contact and cable.

Tools Required		
Size	INSERTION	REMOVAL
12	M81969/8-09 or M81969/14-04	M81969/8-10 or M81969/14-04
16	M81969/8-07 or M81969/14-03	M81969/8-08 or M81969/14-04

Amphenol

Amphenol Aerospace
40-60 Delaware Avenue
Sidney, New York 13838-1395
Website: www.amphenol-aerospace.com