

INSTALLATION DIMENSIONS

FOR

BACK PANEL MOUNTING

BENDIX

ELECTRICAL CONNECTORS

PT, SP AND BP - WALL AND BOX MOUNTING RECEPTACLES

DESCRIPTION: PT Series back panel mounting dimension layout showing maximum usable space ("W" dimension).*

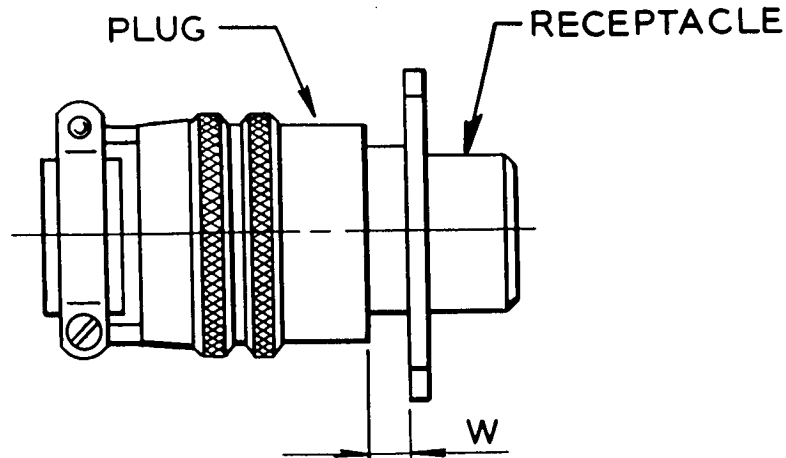

PT SERIES BACK PANEL MOUNTING DIMENSIONS

Shell Size	"W" Max. Usable Space	Shell Size	"W" Max. Usable Space
6	0.094	16	0.094
8	0.094	18	0.094
10	0.094	20	0.219
12	0.094	22	0.219
14	0.094	24	0.219

*NOTE: Screws must be countersunk when PT receptacles are back-panel mounted.

THE *Bendix* CORPORATION
 SCINTILLA DIVISION
 SIDNEY, NEW YORK, U. S. A.

Revised October, 1965

Form L-666
 (Supersedes MG-1134-1)

DESCRIPTION: SP and BP back panel mounting dimension layout showing maximum panel thickness ("W" dimension).

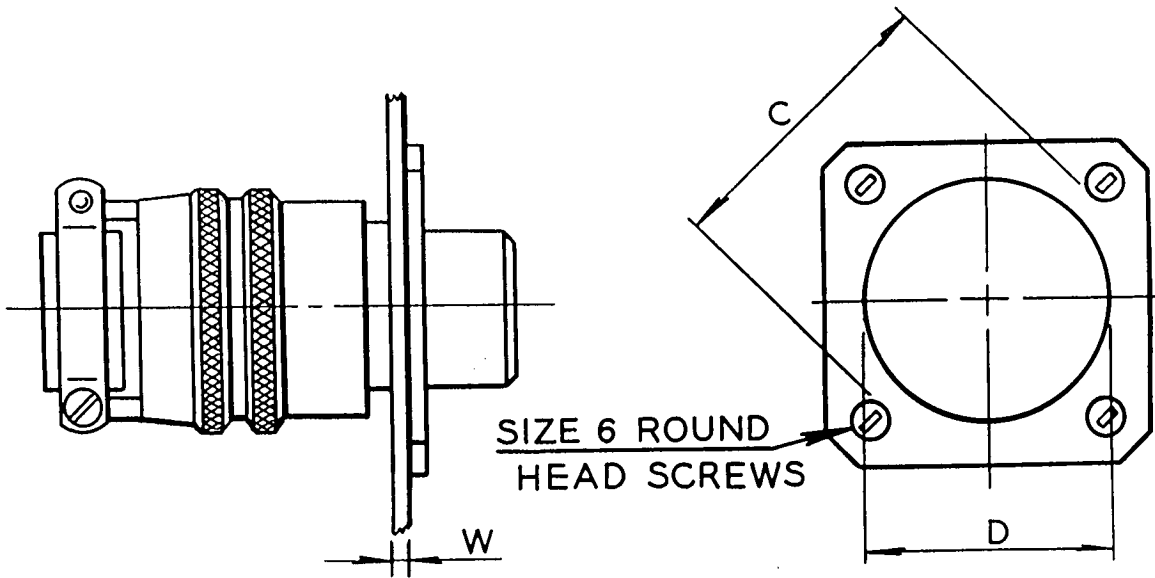

SP AND BP BACK PANEL MOUNTING DIMENSIONS

Shell Size	W Max. Panel	C Clearance Between Screw Heads	D Coupling Nut Max. Dia.
-6	0.125	0.646	0.609
-8	0.125	0.778	0.734
-10	0.125	0.888	0.844
-12	0.125	1.066	1.016
-14	0.125	1.198	1.141
-16	0.125	1.331	1.266
-18	0.125	1.441	1.375
-20	0.219	1.574	1.516
-22	0.219	1.684	1.641
-24	0.219	1.861	1.761

AN/MS, QWL, QWLD, HT, AND BT-M SERIES CONNECTORS.

MAXIMUM ALLOWABLE PANEL THICKNESS*

SHELL SIZE	AN/MS (MIL-C-5015)	Q W L	Q W L D	HT & BT-M
8S	.188			
10S	.188	.156		.188
10SL	.188			.188
12S	.188	.156		.188
12	.125	.156	.156	.125
14S	.188	.156		.188
14	.125	.156	.156	.125
16S	.188	.156		.188
16	.125	.156	.125	.125
18	.125	.156	.125	.125
20	.125	.156	.125	.125
22	.125	.156	.125	.125
24	.188	.187	.187	.188
28	.188	.187	.187	.188
32	.250	.281	.250	.250
36	.250	.281	.218	
40	.250	.281	.218	
44		.281		
48		.281		

*This is the maximum allowable panel thickness between the leading edge of the coupling nut and the front face of the receptacle flange when connectors are in a fully mated condition. No allowances have been made for the thickness of a mounting flange gasket or height of the heads of mounting bolts or screws. These are allowances that the user must provide for in his application and the panel thickness must be decreased accordingly.