

4

3

2

1

ASSEMBLY NUMBER	COAX CONTACT SIZE	USE WITH RG CABLE NUMBER	FERRULE CRIMP TOOL M22520/5-01		OUTER CONTACT	SOCKET KIT	A	B	D	F	J	K	L REF	WT-LB
			DIE PART NO. M22520/5	DIE CLOSURE			DIA ±.0020 -.0005	DIA ±.0020 -.0025		±.003 -.004	±.001	DIA ±.0010		
21-33015-1	8	179/U	-08		21-427-23	21-33084-1	.0280	.0690	.749±.024±.022	.280	.218	.0355	1.511	
21-33015-2	8	59/U	-45	B	-33	-2	.1560			.280				
21-33015-5	8	58C/U	-05	B	-23	-5	.041	.123		.280				
21-33015-9	8	SEE NOTE 7	-45	B	-33	-9	.1560			.280				

51536-182		REVISIONS		
ZONE	LTR	DESCRIPTION	DATE	APPROVED
A1				
A2		REM C COL & DATA, THOMAS & BETTS COL; ADD. .159±.013, FERRULE CRIMP TOOL COL; REV NOTE 1 ECN: 55809-5	6-14-74 Randall	Hanni
B		(MFG) ADDED 21-33015-9 & DATA, NOTE 7. ECN: 58525-66	3-2-77 EDWARDS	Hanni
C		(MFG) ADDED & REL. -5 & DATA ECN: 59500-23	7-13-77 L. HALL	BT

D

D

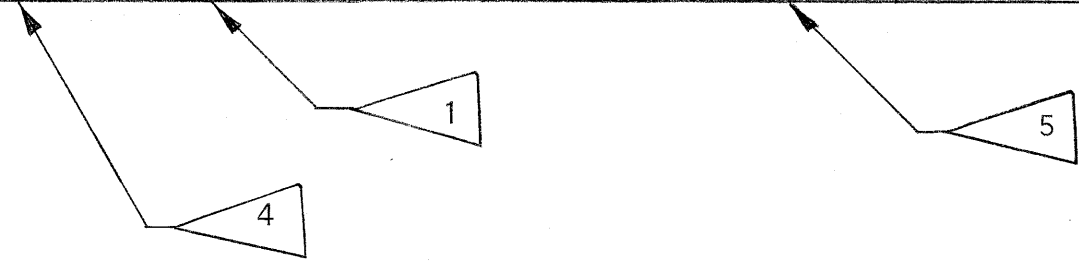

C

C

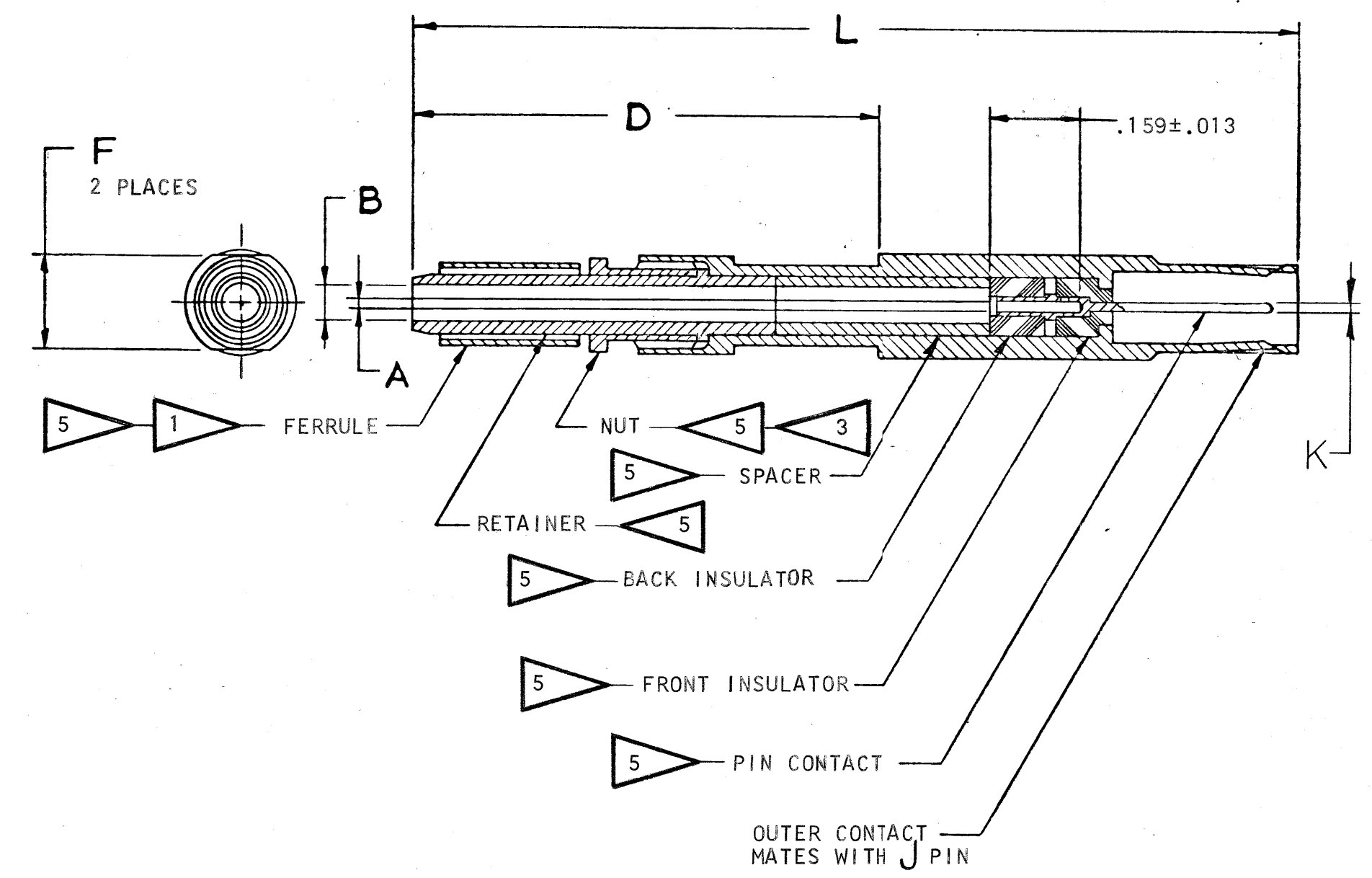

7. FOR USE WITH CABLES:
 A. TIMES TRF 58: TERMINATE AS DOUBLE SHIELD
 B. SPECIAL CABLE: BOSTON TV-43
 .030 DIA NOMINAL CENTER CONDUCTOR
 .140 DIA NOMINAL CORE
 .160 DIA NOMINAL SHIELD
 (36AWG/STRAND)
 .215 DIA NOMINAL JACKET
6. FOR RELEASE STATUS OF DESIRED ASSEMBLY SEE SEPARATE PARTS LIST.
5. DRAWING ILLUSTRATES FINAL ASSY, INDICATED COMPONENTS ARE PART OF SOCKET KIT. SOCKET KIT TO BE PACKAGED PER PRODUCTION PROCESS SHEET.
4. CONTACT ASSEMBLIES WILL ACCOMMODATE OTHER EQUIVALENT COAXIAL CABLE.
3. TORQUE ON NUT FOR SIZE 8 CONTACT SHALL BE 30 TO 36 IN. OZ.
2. ALL DIMENSIONS FOR CUSTOMER INFORMATION ONLY.
1. WHEN ASSEMBLING THIS CONTACT TO SPECIFIED CABLE, CRIMP INDICATED FERRULE WITH TOOL INDICATED IN COLUMN OR EQUIVALENT. FOR COMPLETE INSTALLATION INFORMATION, SEE INSTRUCTIONS L-650.

B

B [21-33015

A

A

NOTES:

FIND NO.	QTY REQD	CODE IDENT	PART NUMBER	DESCRIPTION	NOTE REF
PARTS LIST					
UNLESS OTHERWISE SPECIFIED LINEAR DIMENSIONS ARE IN INCHES. TOLERANCES: .XXX ± .010, .XX ± .03, .X ± .1, ANGLES ± 2°. OTHER STANDARDS PER 9-3800 AND MIL-D-1000. NOTE REF			SIGNATURES PREPARED A. HANNI CHECKED S.A. Lord MATERIAL	DATES 6-18-70 7-24-70	The Bendix Corporation Electrical Components Division Sidney, New York TITLE: CONTACT, SOCKET, ELECTRICAL CONNECTOR, COAXIAL CABLE, TYPE QWL U
MATERIAL SPEC	PROCESS SPEC		APPROVED [Signature] APPROVED [Signature]	7-24-70 7-24-70	
SIZE			CODE IDENT NO.	21-33015	
C			77820		
SCALE NONE		WT SEE COLUMN	REF 21-33011	SHEET	

NEXT ASSEMBLY

USE OF THIS DOCUMENT IS UNLIMITED. DOCUMENTS REFERENCED HEREON CONTAIN LIMITED RIGHTS DATA.

105059511

TAB. 44-2