

4

3

2

1

REVISIONS				
ZONE	LTR	DESCRIPTION	DATE	APPROVED
—	E	(CLII) WAS 21-33321-1 (F/N 8) ECN:20958-1	11/07/88 NEJ	<i>B. Palmer</i>

D

D

C

C

B

B

A

A

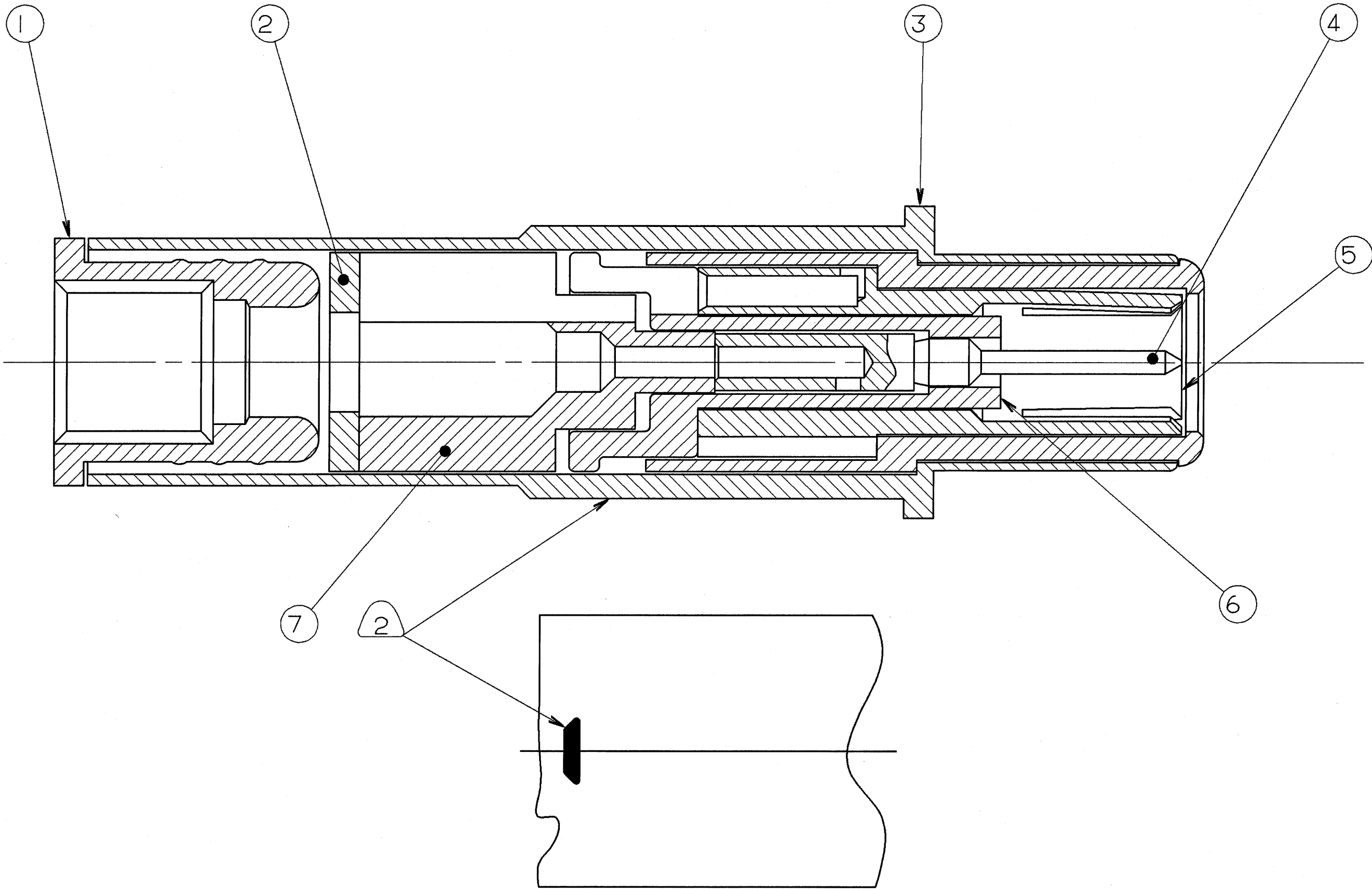

- 6. MEETS THE REQUIREMENTS OF M39029/90-529, EXCEPT FOR THE HEAT SHRINK BOOT REQUIREMENTS AND LESS COLOR BANDS.
- 5. INDICATED ITEM NOT ILLUSTRATED.
- 4. CONTACT WILL ACCOMODATE MI7/176-00002 CABLE.
- 3. DRAWING ILLUSTRATES FINAL ASSEMBLY. COMPLETE INSTALLATION INSTRUCTIONS F/N 9, PACKED WITH EACH ASSEMBLY. PACKAGE PER PRODUCTION PROCESS SHEET.
- 2. BLACK INK STAMP TRADEMARK 9-6700 TYPE IV. PER 9-7530 OR 9-3856-5, IN APPROXIMATE POSITION SHOWN. TRADEMARK MAY BE SOLID AS SHOWN.
- 1. PROCESS SPEC:
TEST 9-5272-30
9-6700, 9-7530, 9-3856-5

NOTES:

THE USE OF THIS DOCUMENT IS UNLIMITED. HOWEVER, DOCUMENTS REFERENCED HEREON MAY CONTAIN LIMITED RIGHTS DATA.

GENERAL USE
NEXT ASSEMBLY

UNLESS OTHERWISE SPECIFIED LINEAR DIMENSIONS ARE IN INCHES.
TOLERANCES: .XXX±.010,
.XX ±.03, .X ±.1,
ANGLES ±2°.
OTHER STANDARDS PER 9-3800 AND DOD-D-1000.
NOTE REF. =

FIND NO.	QTY REQD.	FSCM NO.	PART NUMBER	DESCRIPTION	NOTE REF.
9	1		21-33320	INSTALLATION INSTRUCTIONS	5
8	1		21-33321-5	PIGGYBACK SEAL	5
7	1		21-33305-1	INSULATOR	
6	1		21-33309-1	INSULATOR	
5	1		21-33313-15	CONTACT	
4	1		21-33316-15	CONTACT	
3	1		21-33312-25	CONTACT	
2	1		21-33304-1	SPACER	
1	1		21-33303-15	BUSHING	

PARTS LIST					
SPECIFICATIONS	SIGNATURES	DATES	AMPHENOL CORPORATION BENDIX CONNECTOR OPERATIONS SIDNEY, N.Y.		
MATERIAL SPEC. N/A	PREPARED HEMMER	4/19/84	CONTACT, PIN, CONCENTRIC TWINAX, SIZE 8		
	CHECKED DAVIS	5/30/84			
	MATERIAL WILLIAMS	5/31/84			
	APPROVED HEMMER	5/30/84			
PROCESS SPEC. SEE NOTE 1	APPROVED DAVIS	5/30/84	SIZE	FSCM NO.	REV.
	1ST PART NO.		C	77820	E
			SCALE	WT.	SHEET
			10/1		N/A