

2/18/85		REVISIONS		76500-32	
ZONE	LTR	DESCRIPTION	DATE	APPROVED	
—	B	(CLII)CHG'D NOTES 1 & 2 ECN:78167-1	4/9/87 CODINGTON	<i>[Signature]</i>	

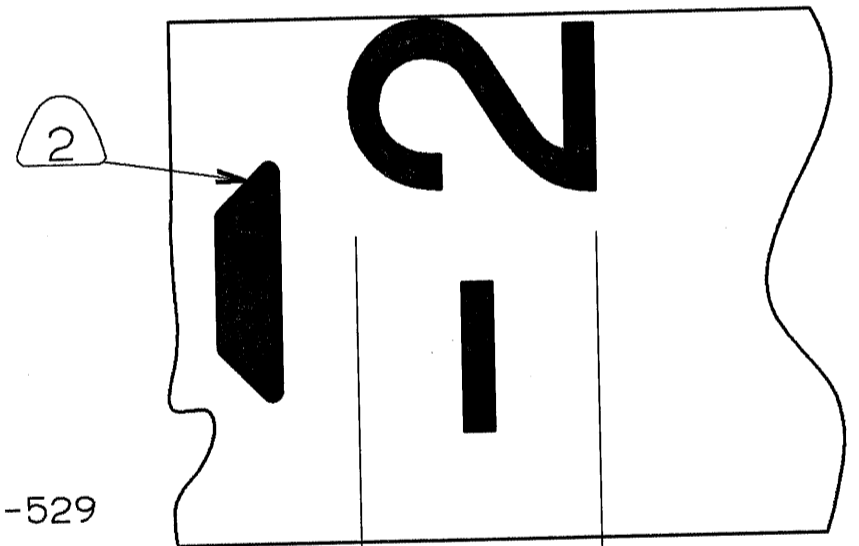
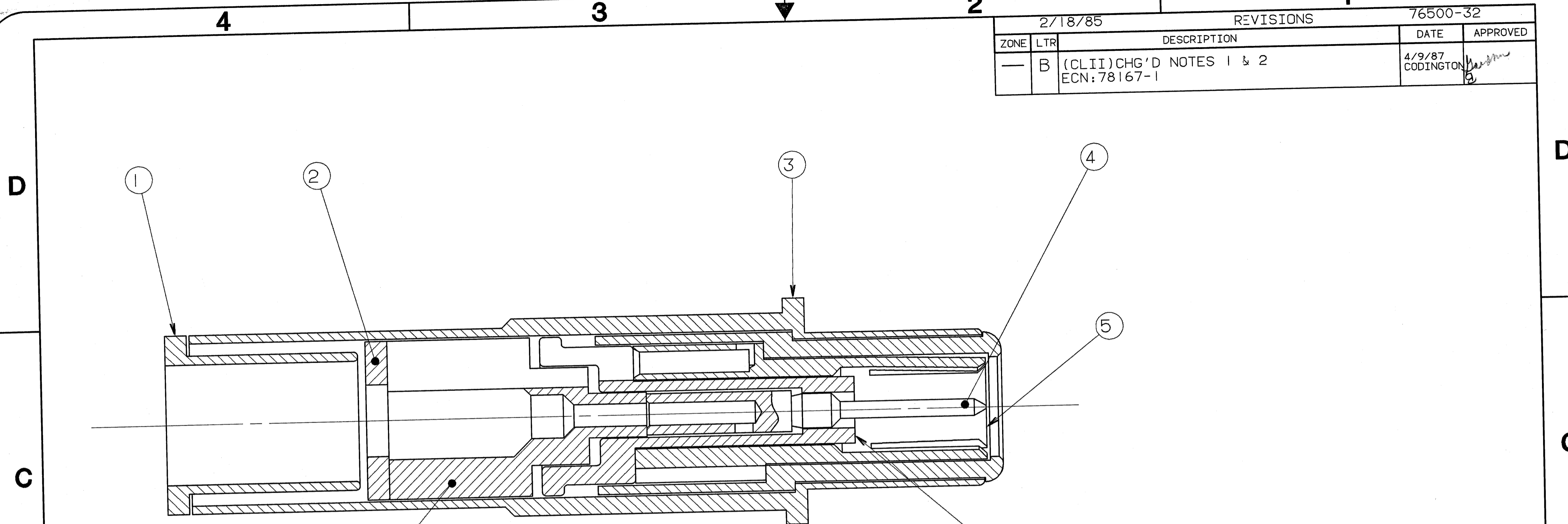

6. MEETS THE REQUIREMENTS OF MIL-C-39029/90-529 EXCEPT FOR HEAT SHRINK BOOT REQUIREMENT, CRIMP BUSHING DIAMETERS (F/N 1) AND LESS COLOR BANDS. (PIGGYBACK GROMMET SEAL SUPPLIED WITH CONNECTOR ASSEMBLY).
5. INDICATED ITEM NOT ILLUSTRATED.
4. CONTACT WILL ACCOMODATE RAYCHEM CABLE PART NUMBER 10614.
3. DRAWING ILLUSTRATES FINAL ASSEMBLY. COMPLETE INSTALLATION INSTRUCTIONS F/N 8, PACKED WITH EACH ASSEMBLY. PACKAGE PER PRODUCTION PROCESS SHEET.
2. BLACK INK STAMP -22 AND TRADEMARK 9-6700 TYPE IV, PER 9-7530 OR 9-3856-5, IN APPROXIMATE POSITION SHOWN. DIRECTION OPTIONAL. TRADEMARK MAY BE SOLID AS SHOWN.
1. PROCESS SPEC:
TEST 9-5272-30
9-6700, 9-7530, 9-3856-5

FIND NO.	QTY REQD.	FSCM NO.	PART NUMBER	DESCRIPTION	NOTE REF.
8	1		21-33348-1	INSTALLATION INSTRUCTIONS	9
7	1		21-33305-1	INSULATOR	
6	1		21-33309-1	INSULATOR	
5	1		21-33313-15	CONTACT	
4	1		21-33316-15	CONTACT	
3	1		21-33312-25	CONTACT	
2	1		21-33304-1	SPACER	
1	1		21-33303-25	BUSHING	6

UNLESS OTHERWISE SPECIFIED
LINEAR DIMENSIONS ARE IN
INCHES.
TOLERANCES: .XXX±.010,
.XX ±.03, .X ±.1,
ANGLES ±2°.
OTHER STANDARDS PER 9-3800
AND DOD-D-1000.
NOTE REF. =

PARTS LIST			AMPHENOL CORPORATION BENDIX CONNECTOR OPERATIONS SIDNEY, N.Y.	
SPECIFICATIONS	SIGNATURES	DATES	SIZE	FSCM NO.
MATERIAL SPEC. N/A	PREPARED HEMMER CHECKED KELLER MATERIAL	12/18/84 2/18/85	C	77820
PROCESS SPEC. SEE NOTE 1	APPROVED HEMMER APPROVED DAVIS 1ST PART NO.	2/6/85 2/18/85	SCALE	10/1
			WT.	REF 21-33190-529
			SHEET	N/A

NOTES:
THE USE OF THIS DOCUMENT IS UNLIMITED.
HOWEVER, DOCUMENTS REFERENCED HEREON
MAY CONTAIN LIMITED RIGHTS DATA.

GENERAL USE
NEXT ASSEMBLY