

2/5/87		REVISIONS	78500-23
ZONE	LTR	DESCRIPTION	DATE
—	B	(CLII)SEE CHANGE NOTICE ECN:78171-1	4/13/87 BIVIANO
			APPROVED <i>R. J. ...</i>

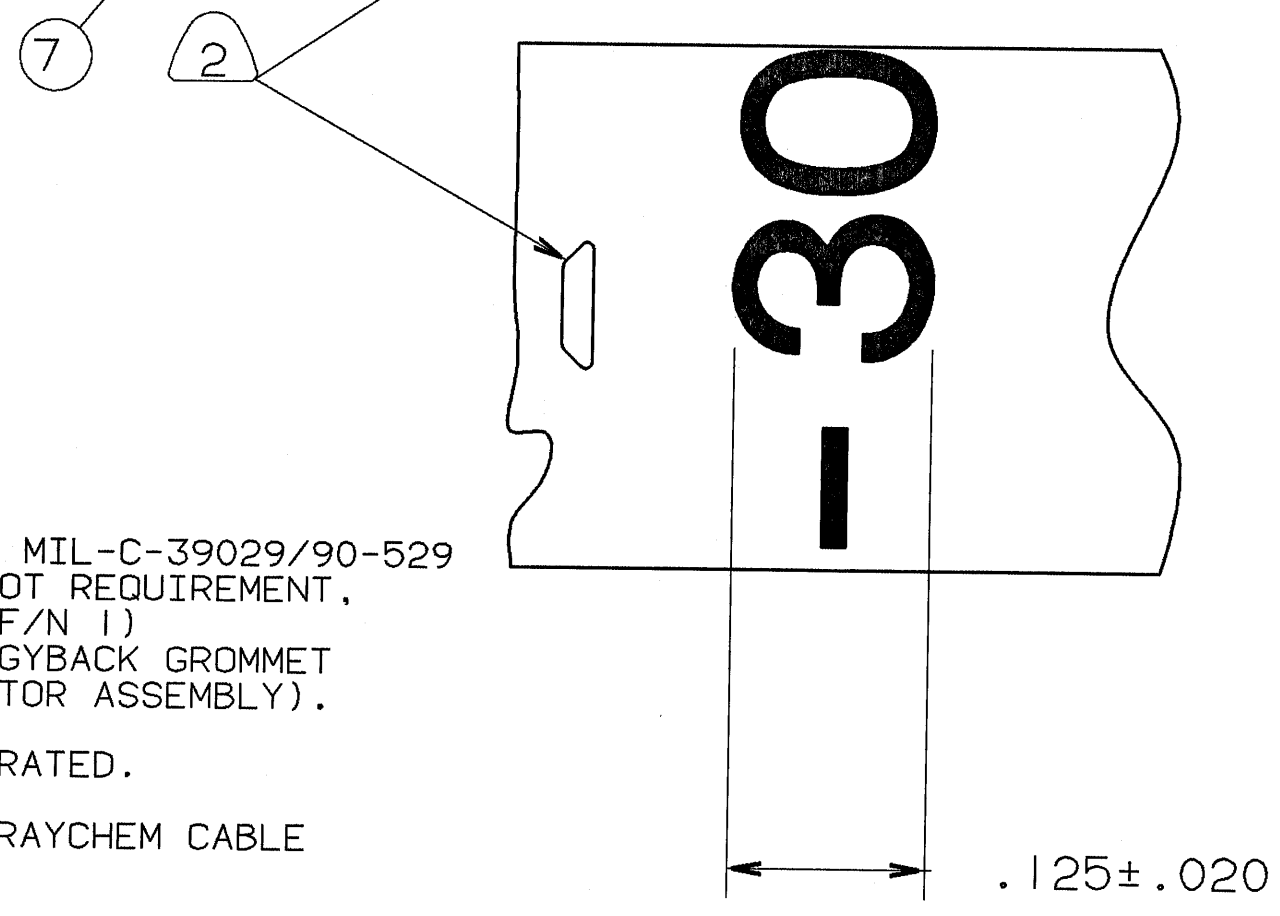
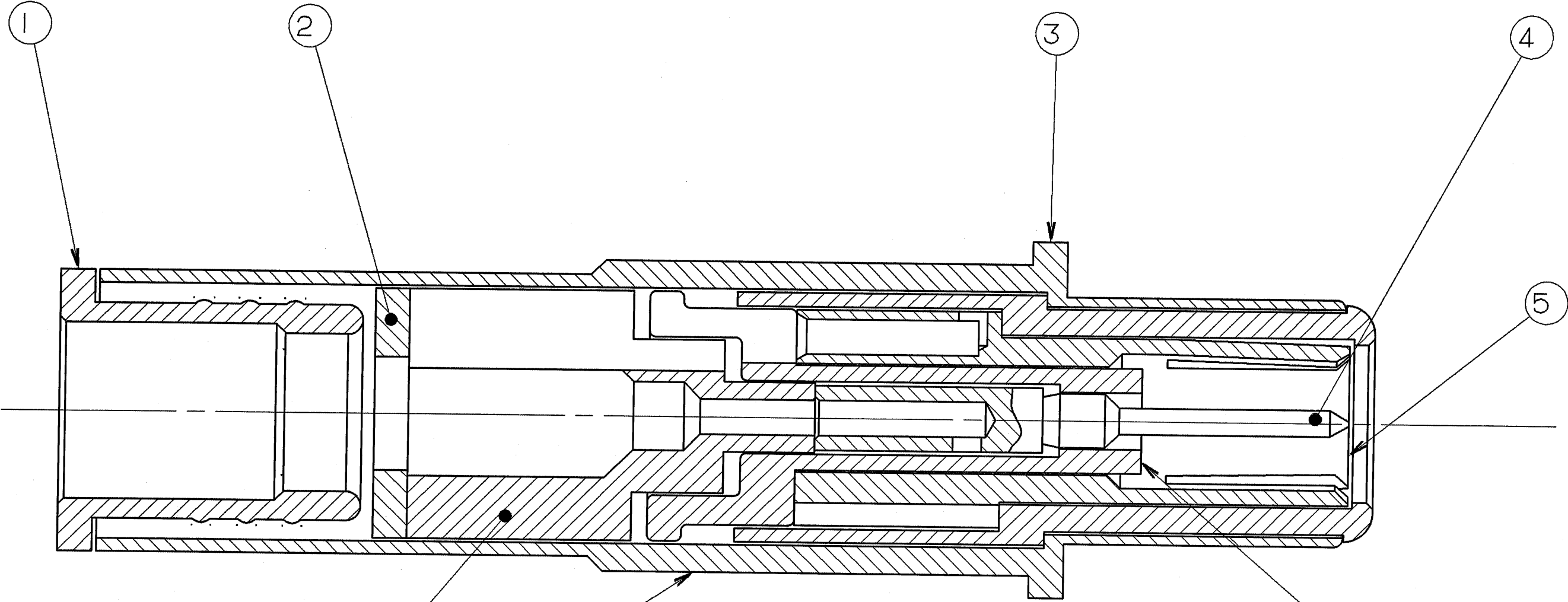

6. MEETS THE REQUIREMENTS OF MIL-C-39029/90-529 EXCEPT FOR HEAT SHRINK BOOT REQUIREMENT, CRIMP BUSHING DIAMETERS (F/N 1) AND LESS COLOR BANDS. (PIGGYBACK GROMMET SEAL SUPPLIED WITH CONNECTOR ASSEMBLY).
5. INDICATED ITEM NOT ILLUSTRATED.
4. CONTACT WILL ACCOMMODATE RAYCHEM CABLE PART NUMBER 10613.
3. DRAWING ILLUSTRATES FINAL ASSEMBLY. COMPLETE INSTALLATION INSTRUCTIONS F/N 8, PACKED WITH EACH ASSEMBLY. PACKAGE PER PRODUCTION PROCESS SHEET.
2. BLACK INK STAMP -30 AND TRADEMARK (PER 9-6700, TYPE IV), PER 9-7530 OR 9-3856-5, IN APPROXIMATE POSITION SHOWN. DIRECTION OPTIONAL. TRADEMARK MAY BE SOLID AS SHOWN.
1. PROCESS SPEC:
TEST 9-5272-30
9-6700, 9-7530, 9-3856-5

FIND NO.	QTY REQD.	FSCM NO.	PART NUMBER	DESCRIPTION	NOTE REF.
8	1		21-33348-5	INSTALLATION INSTRUCTIONS	5
7	1		21-33305-1	INSULATOR	
6	1		21-33309-1	INSULATOR	
5	1		21-33313-15	CONTACT	
4	1		21-33316-15	CONTACT	
3	1		21-33312-25	CONTACT	
2	1		21-33304-1	SPACER	
1	1		21-33303-35	BUSHING	

UNLESS OTHERWISE SPECIFIED
LINEAR DIMENSIONS ARE IN
INCHES.
TOLERANCES: .XXX±.010,
.XX ±.03, .X ±.1,
ANGLES ±2°.
OTHER STANDARDS PER 9-3800
AND DOD-D-1000.
NOTE REF. = **XX**

PARTS LIST				AMPHENOL CORPORATION BENDIX CONNECTOR OPERATIONS SIDNEY, N.Y.	
SPECIFICATIONS	SIGNATURES	DATES	CONTACT, PIN, CONCENTRIC TWINAX SIZE 8		
MATERIAL SPEC. N/A	PREPARED HEMMER	11/12/86			
	CHECKED KELLER	2/5/87			
	MATERIAL				
PROCESS SPEC. SEE NOTE 1	APPROVED J. BAKER	2/4/87	SIZE	FSCM NO.	REV.
	APPROVED AL. DAVIS	2/5/87	C	77820	B
	1ST PART NO.		SCALE	WT.	SHEET
			10/1		N/A

NOTES:
THE USE OF THIS DOCUMENT IS UNLIMITED.
HOWEVER, DOCUMENTS REFERENCED HEREON
MAY CONTAIN LIMITED RIGHTS DATA.

GENERAL USE
NEXT ASSEMBLY