

REV. A		SHEET 1 OF 1		DOCUMENT NO. 21-033190-090	
REVISIONS					
LTR	DESCRIPTION			DATE	
A	INITIAL RELEASE			-	

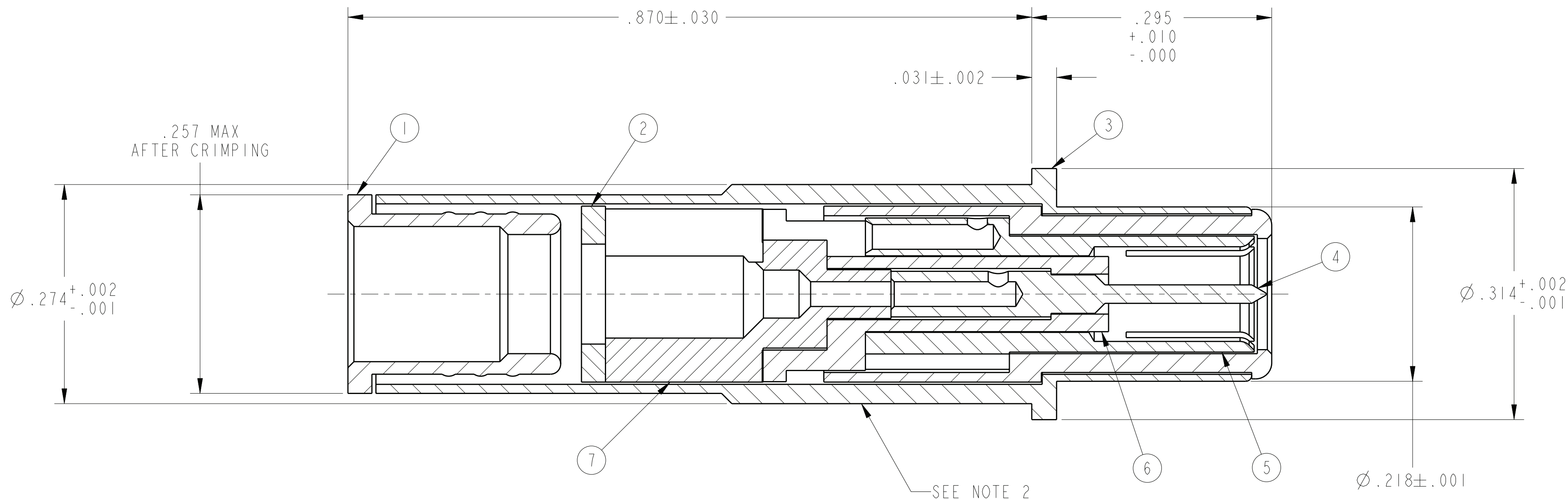

8. THIS CONTACT UTILIZES PIGGYBACK GROMMET SEAL 21-33321-5 SUPPLIED WITH THE ELECTRICAL CONNECTOR ASSEMBLY.
7. MATES WITH 21-33191-() TWINAX SOCKET CONTACT ASSEMBLIES.
6. MEETS THE APPLICABLE REQUIREMENTS OF M39029/90-529, EXCEPT FOR THE HEAT SHRINK BOOT REQUIREMENTS AND LESS COLOR BANDS.
5. INDICATED ITEM NOT ILLUSTRATED.
4. CONTACT WILL ACCOMODATE PIC EI0224 CABLE OR EQUIVALENT.
3. DRAWING ILLUSTRATES FINAL ASSEMBLY. COMPLETE INSTALLATION INSTRUCTIONS F/N 8, PACKED WITH EACH ASSEMBLY. PACKAGE PER PRODUCTION PROCESS SHEET.
2. IF NOT PREVIOUSLY STAMPED, BLACK INK STAMP TRADEMARK 9-6700 TYPE IV, PER 9-7530 OR 9-3856-5. IN APPROXIMATE POSITION SHOWN. DIRECTION OPTIONAL. TRADEMARK MAY BE SOLID OR FRAME.

1. PROCESS SPEC:
TEST 9-5272-30
NOTES: 9-6700, 9-7530, 9-3856-5

THE USE OF THIS DOCUMENT IS UNLIMITED. HOWEVER, DOCUMENTS REFERENCED HEREON MAY CONTAIN LIMITED RIGHTS DATA.

RELEASED / Jun . 17 2009, 2:53:15 PM

DOCUMENT NO. 21-033190-090

SHEET 1 OF 1

REV. A

PRO/ENGINEER INFORMATION
Pro/e Model Used:
21-033191-090.ASSEM
Drawing Name:
21-033190-090

N/A

NEXT ASSEMBLY

UNLESS OTHERWISE SPECIFIED

SPECIFICATIONS
MATERIAL SPEC.
N/A

PROCESS SPEC.
SEE NOTE 1



=FLAG NOTE CALL OUT REFERENCE ONLY

SPECIFICATIONS

MATERIAL SPEC.

PROCESS SPEC.

SEE NOTE 1

POS	QTY	PART NUMBER	DESCRIPTION	NOTE
8	1	L-1253-AC	INSTALLATION INSTRUCTIONS	5
7	1	21-033305-001	INSULATOR	
6	1	21-033309-001	INSULATOR	
5	1	21-033313-015	CONTACT	
4	1	21-033316-015	CONTACT	
3	1	21-033312-025	CONTACT	
2	1	21-033304-003	SPACER	
1	1	21-033303-835	BUSHING	

APPROVALS	DATE
PREPARED BY RATCHFORD	
ENGINEER IN CHARGE RATCHFORD	
DESIGN MANAGER SHEPLER	04-Jun-09
DESIGN ACTIVITY GROUP MIL-AERO DEVELOP	

THIRD ANGLE PROJECTION

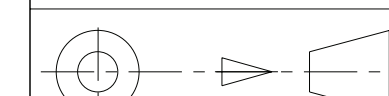

PARTS LIST			
AMPHENOL CORPORATION 40-60 DELAWARE AVENUE SIDNEY, N.Y. 13858			
CONTACT, PIN, SIZE 8, CONCENTRIC TWINAX			
SIZE C	CAGE CODE 77820	DOCUMENT NO. 21-033190-090	REV. A
SCALE: 10:0		REF. 21-33190-71	SHEET 1 OF 1

DOCUMENT NO. 21-033190-090
 SHEET 1 OF 1
 REV. A
 RELEASE STATE WIP
 REVISION A
 VERSION 0