

REV. A	SHEET 1 OF 1	21-033190-261
REVISIONS M		
LTR	DESCRIPTION	DATE
A	INITIAL RELEASE	---

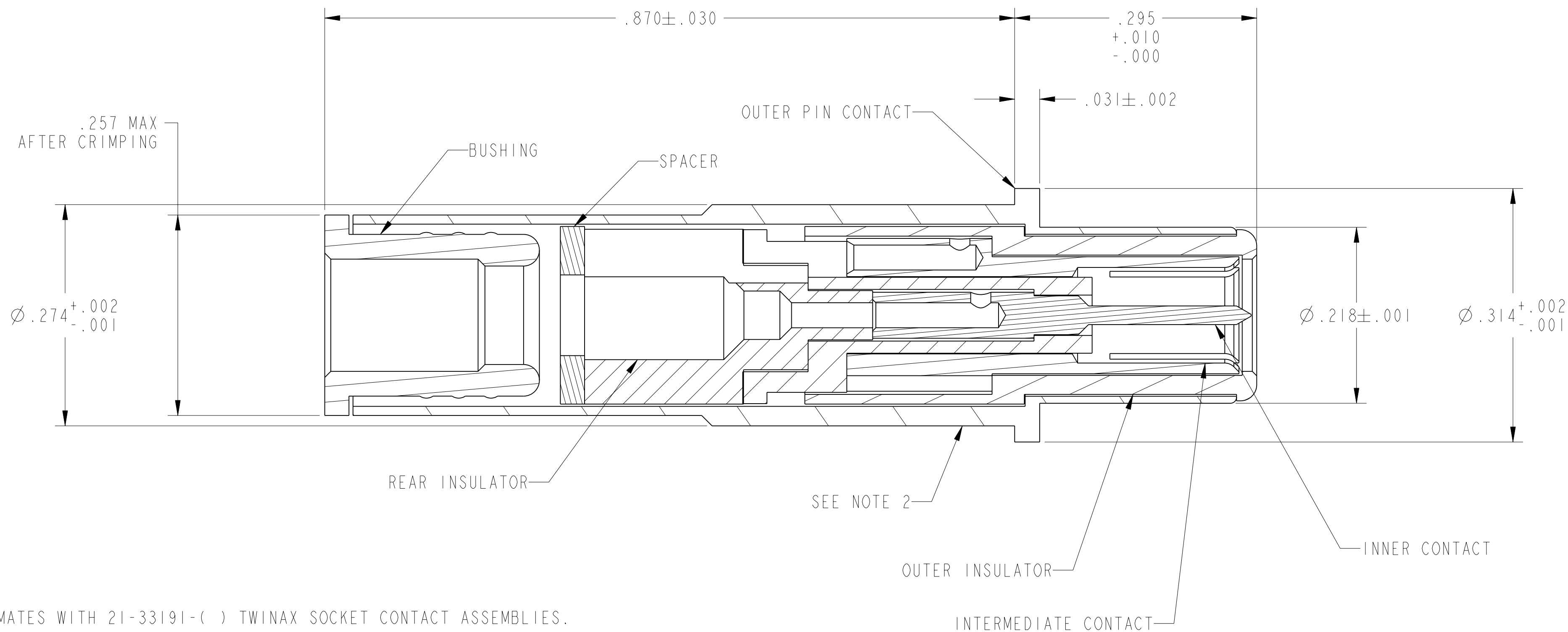

- MATES WITH 21-33191-() TWINAX SOCKET CONTACT ASSEMBLIES.
- MEETS THE APPLICABLE REQUIREMENTS OF M39029/90-529, EXCEPT FOR THE HEAT SHRINK BOOT REQUIREMENTS AND LESS COLOR BANDS.
- CONTACT ASSEMBLIES ARE SHIPPED WITH PIGGYBACK SEAL. PIGGYBACK SEAL NOT ILLUSTRATED.
- CONTACT WILL ACCOMODATE RAYCHEM 10612 TWINAX CABLE OR EQUIVALENT.
- DRAWING ILLUSTRATES FINAL ASSEMBLY. COMPLETE INSTALLATION INSTRUCTIONS ARE PACKED WITH EACH ASSEMBLY. PACKAGE PER PRODUCTION PROCESS SHEET.
- TRADEMARK STAMPED IN APPROXIMATE POSITION SHOWN. DIRECTION OPTIONAL.

1. PROCESS SPEC:
9-7530, 9-3856-5

NOTES:

THE USE OF THIS DOCUMENT IS UNLIMITED. HOWEVER, DOCUMENTS REFERENCED HEREON MAY CONTAIN LIMITED RIGHTS DATA.

RELEASED / Jul . 18 2014, 3:56:14 PM

21-033190-261

SHEET 1 OF 1

REV. A

PRO/ENGINEER INFORMATION
Pro/e Model Used:
21-033190-261.ASSEM
Drawing Name:
21-033190-261

N/A

NEXT ASSEMBLY

UNLESS OTHERWISE SPECIFIED	SPECIFICATIONS	POS	QTY	PART NUMBER	DESCRIPTION	NOTE
LINEAR DIMENSIONS ARE IN INCHES TOLERANCES: .XXXX = ±.0005 ANGLES= ±2° .XXX = ±.010 .XX = ±.03 .X = ±.1 DIM. & TOL. PER ASME Y14.5M; DRM PER MIL-DTL-31000; OTHER Amphenol Stds. PER 9-3800 LEGENDS: =FLAG NOTE CALL OUT REFERENCE ONLY	MATERIAL SPEC.	PARTS LIST AMPHENOL CORPORATION 40-60 DELAWARE AVENUE SIDNEY, N.Y. 13858 CONTACT, PIN, SIZE 8, CONCENTRIC TWINAX, TYPE M38999				
	N/A					
PROCESS SPEC.	SEE NOTE 1	APPROVALS PREPARED BY J. CARNEVALE ENGINEER IN CHARGE D. PHILLIPS DESIGN MANAGER E. HICKEY DESIGN ACTIVITY GROUP CI DATE 02-Jul-14 THIRD ANGLE PROJECTION				
SIZE C CAGE CODE 77820 SCALE: 10:0		DOCUMENT NO. 21-033190-261 REF. 21-33190-26		REV. A SHEET 1 OF 1		

21-033190-261

SHEET 1 OF 1

REV. A

C

B

A

Eng PDM Information For Reference Only

SHEET 1 OF 1

21-033190-261