

REVISIONS				
ZONE	LTR	DESCRIPTION	DATE	APPROVED
—	C	(CLII)SEE CHANGE NOTICE ECN:78168-1	4/10/87 CODINGTON	<i>[Signature]</i> P

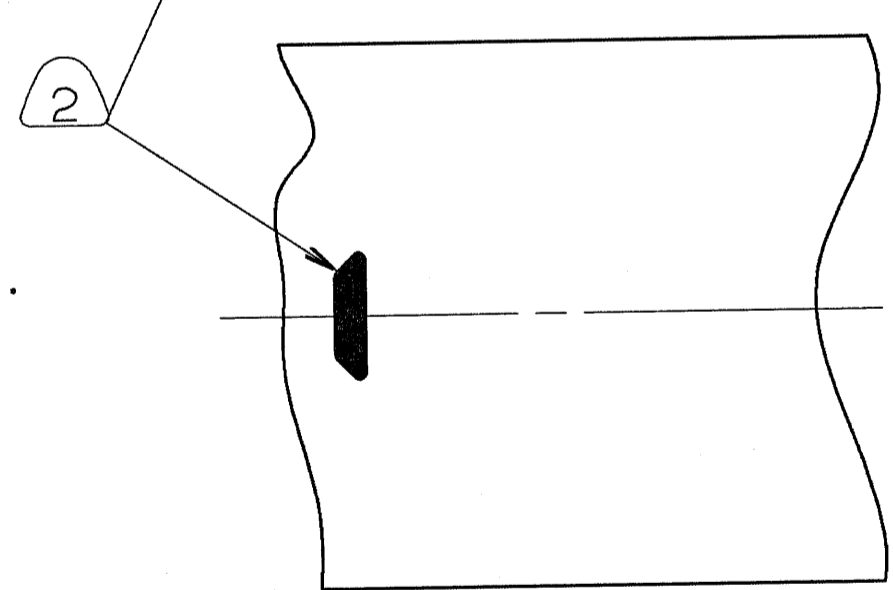
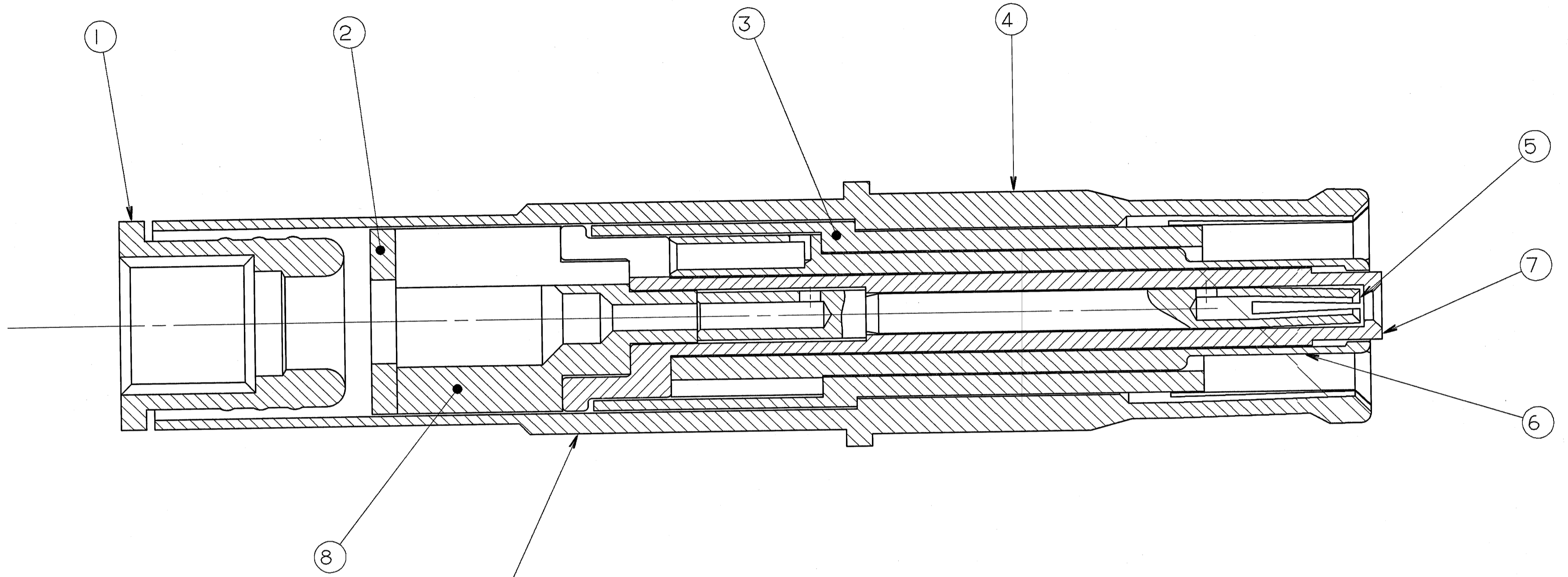

6. MEETS THE REQUIREMENTS OF M39029/91-530, EXCEPT FOR THE HEAT SHRINK BOOT REQUIREMENTS, AND LESS COLOR BANDS.
5. INDICATED ITEM NOT ILLUSTRATED.
4. CONTACT WILL ACCOMODATE MI7/176-00002 CABLE.
3. DRAWING ILLUSTRATES FINAL ASSEMBLY. COMPLETE INSTALLATION INSTRUCTIONS F/N 9, PACKED WITH EACH ASSEMBLY. PACKAGE PER PRODUCTION PROCESS SHEET.
2. BLACK INK STAMP TRADEMARK 9-6700 TYPE IV, PER 9-7530 OR 9-3856-5, IN APPROXIMATE POSITION SHOWN. DIRECTION OPTIONAL. TRADEMARK MAY BE SOLID AS SHOWN.
1. PROCESS SPEC:  
TEST 9-5272-30  
9-6700, 9-7530, 9-3856-5

NOTES:  
THE USE OF THIS DOCUMENT IS UNLIMITED. HOWEVER, DOCUMENTS REFERENCED HEREON MAY CONTAIN LIMITED RIGHTS DATA.

GENERAL USE  
NEXT ASSEMBLY

UNLESS OTHERWISE SPECIFIED  
LINEAR DIMENSIONS ARE IN INCHES.  
TOLERANCES: .XXX±.010,  
.XX ±.03, .X ±.1,  
ANGLES ±2°.  
OTHER STANDARDS PER 9-3800  
AND DOD-D-1000.  
NOTE REF. = **XX**

FIND NO.	QTY REQD.	FSCM NO.	PART NUMBER	DESCRIPTION	NOTE REF.
9	1		21-33319	INSTALLATION INSTRUCTIONS	5
8	1		21-33305-1	INSULATOR	
7	1		21-33308-1	INSULATOR	
6	1		21-33314-15	CONTACT	
5	1		21-33315-15	CONTACT	
4	1		21-33311-25	CONTACT	
3	1		21-33307-1	INSULATOR	
2	1		21-33304-1	SPACER	
1	1		21-33303-15	BUSHING	

PARTS LIST			AMPHENOL CORPORATION BENDIX CONNECTOR OPERATIONS SIDNEY, N.Y.		
SPECIFICATIONS	SIGNATURES	DATES	SIZE	FSCM NO.	REV.
MATERIAL SPEC. N/A	PREPARED HEMMER	4/19/84	C	77820	C
PROCESS SPEC. SEE NOTE 1	CHECKED DAVIS	5/30/84	SCALE	WT.	
	MATERIAL WILLIAMS	5/31/84	10/1		
	APPROVED HEMMER	5/30/84	REF	21-33191-530	SHEET N/A
	APPROVED DAVIS	5/30/84	1ST PART NO.		