

REVISIONS				
ZONE	LTR	DESCRIPTION	DATE	APPROVED
—	D	(CLII)SEE CHANGE NOTICE ECN:78168-1	4/10/87 CODINGTON	<i>[Signature]</i> P

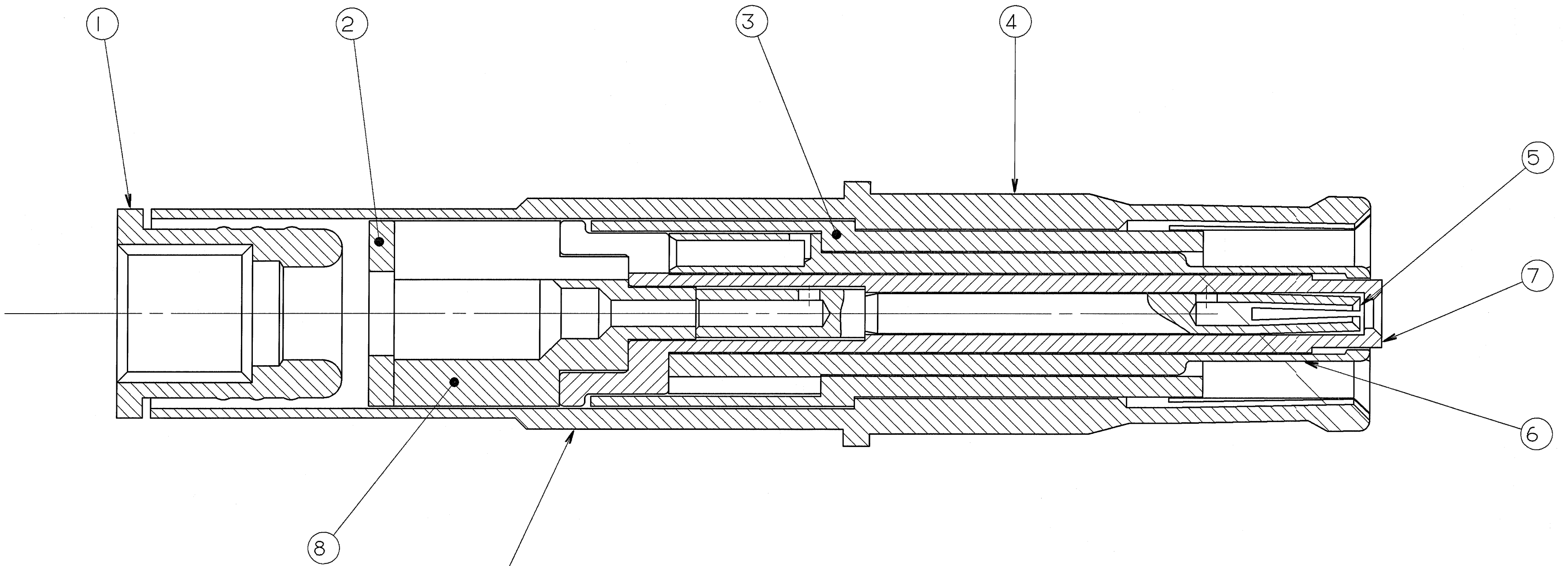

6. MEETS THE REQUIREMENTS OF M39029/91-530, EXCEPT FOR THE HEAT SHRINK BOOT REQUIREMENTS AND LESS COLOR BANDS.

5. INDICATED ITEM NOT ILLUSTRATED.

4. CONTACT WILL ACCOMMODATE MI7/176-00002 CABLE.

3. DRAWING ILLUSTRATES FINAL ASSEMBLY. COMPLETE INSTALLATION INSTRUCTIONS (F/N 10), PACKED WITH EACH ASSEMBLY. PACKAGE PER PRODUCTION PROCESS SHEET.

2. BLACK INK STAMP TRADEMARK 9-6700 TYPE IV, PER 9-7530 OR 9-3856-5 IN APPROXIMATE POSITION SHOWN. DIRECTION OPTIONAL. TRADEMARK MAY BE SOLID AS SHOWN.

1. PROCESS SPEC:
TEST 9-5272-30
9-6700, 9-7530, 9-3856-5

NOTES:

THE USE OF THIS DOCUMENT IS UNLIMITED. HOWEVER, DOCUMENTS REFERENCED HEREON MAY CONTAIN LIMITED RIGHTS DATA.

GENERAL USE
NEXT ASSEMBLY

UNLESS OTHERWISE SPECIFIED LINEAR DIMENSIONS ARE IN INCHES.
TOLERANCES: .XXX±.010,
.XX ±.03, .X ±.1,
ANGLES ±2°.
OTHER STANDARDS PER 9-3800 AND DOD-D-1000.
NOTE REF. =

FIND NO.	QTY REQD.	FSCM NO.	PART NUMBER	DESCRIPTION	NOTE REF.
10	1		21-33319	INSTALLATION INSTRUCTIONS	5
9	1		21-33321-5	PIGGYBACK SEAL	5
8	1		21-33305-1	INSULATOR	
7	1		21-33308-1	INSULATOR	
6	1		21-33314-15	CONTACT	
5	1		21-33315-15	CONTACT	
4	1		21-33311-25	CONTACT	
3	1		21-33307-1	INSULATOR	
2	1		21-33304-1	SPACER	
1	1		21-33305-15	BUSHING	

PARTS LIST			AMPHENOL CORPORATION BENCIX CONNECTOR OPERATIONS SIDNEY, N.Y.	
SPECIFICATIONS	SIGNATURES	DATES	SIZE	FSCM NO.
MATERIAL SPEC. N/A	PREPARED HEMMER CHECKED DAVIS MATERIAL WILLIAMS	4/19/84 5/30/84 5/31/84	C	77820
PROCESS SPEC. SEE NOTE 1	APPROVED HEMMER APPROVED DAVIS 1ST PART NO.	5/30/84 5/30/84	SCALE	WT.
			10/1	REF 21-33191-530
			SHEET	N/A