

2/18/85		REVISIONS		76500-32	
ZONE	LTR	DESCRIPTION	DATE	APPROVED	
—	B	(CLII)CHG'D NOTES 1 & 2 ECN:78167-1	4/9/87 CODINGTON	<i>[Signature]</i>	

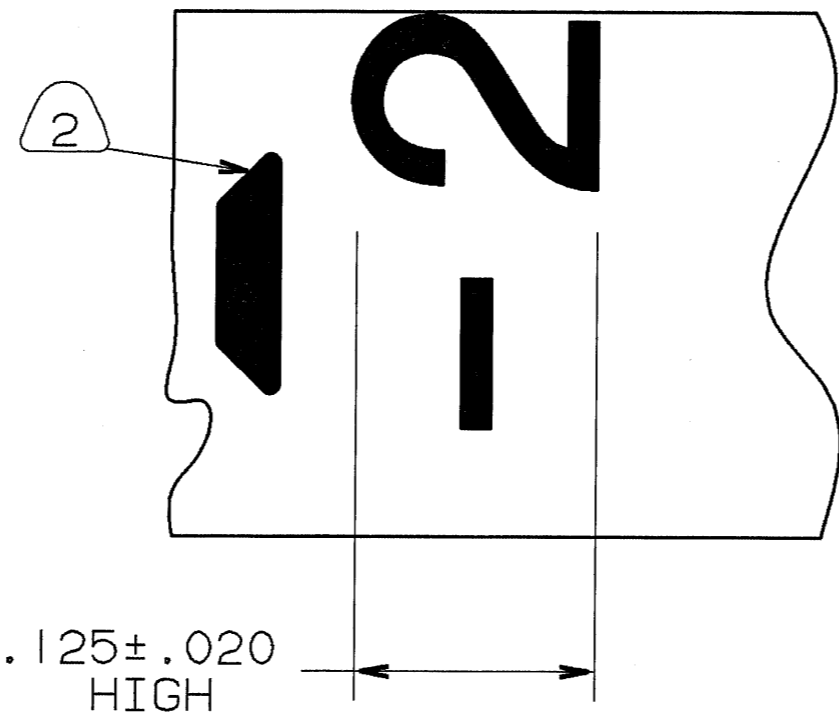
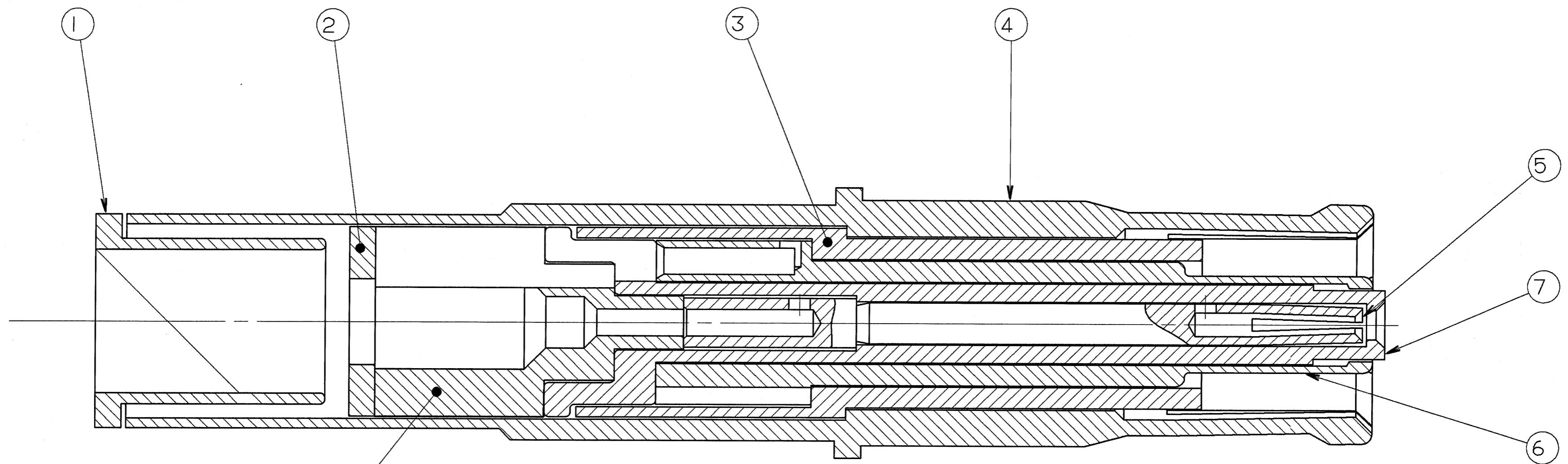

- 6. MEETS THE REQUIREMENTS OF MIL-C-39029/91-530 EXCEPT FOR HEAT SHRINK BOOT REQUIREMENT, CRIMP BUSHING DIAMETERS (F/N 1) AND LESS COLOR BANDS. (PIGGYBACK GROMMET SEAL SUPPLIED WITH CONNECTOR ASSEMBLY).
- 5. INDICATED ITEM NOT ILLUSTRATED.
- 4. CONTACT WILL ACCOMODATE RAYCHEM CABLE PART NUMBER 10614.
- 3. DRAWING ILLUSTRATES FINAL ASSEMBLY. COMPLETE INSTALLATION INSTRUCTIONS (F/N 9), PACKED WITH EACH ASSEMBLY. PACKAGE PER PRODUCTION PROCESS SHEET.
- 2. BLACK INK STAMP -22 AND TRADEMARK (PER 9-6700, TYPE IV), PER 9-7530 OR 9-3856-5, IN APPROXIMATE POSITION SHOWN. DIRECTION OPTIONAL. TRADEMARK MAY BE SOLID AS SHOWN.

1. PROCESS SPEC:
TEST 9-5272-30
9-6700, 9-7530, 9-3856-5

NOTES:
THE USE OF THIS DOCUMENT IS UNLIMITED. HOWEVER, DOCUMENTS REFERENCED HEREON MAY CONTAIN LIMITED RIGHTS DATA.

GENERAL USE
NEXT ASSEMBLY

UNLESS OTHERWISE SPECIFIED LINEAR DIMENSIONS ARE IN INCHES.
TOLERANCES: .XXX±.010,
.XX ±.03, .X ±.1,
ANGLES ±2°.
OTHER STANDARDS PER 9-3800
AND DOD-D-1000.
NOTE REF. = **XX**

FIND NO.	QTY REQD.	FSCM NO.	PART NUMBER	DESCRIPTION	NOTE REF.
9	1		21-33349-1	INSTALLATION INSTRUCTIONS	5
8	1		21-33305-1	INSULATOR	
7	1		21-33308-1	INSULATOR	
6	1		21-33314-15	CONTACT	
5	1		21-33315-15	CONTACT	
4	1		21-33311-25	CONTACT	
3	1		21-33307-1	INSULATOR	
2	1		21-33304-1	SPACER	
1	1		21-33303-25	BUSHING	6

PARTS LIST			AMPHENOL CORPORATION BENDIX CONNECTOR OPERATIONS SIDNEY, N.Y.	
SPECIFICATIONS	SIGNATURES	DATES	SIZE	FSCM NO.
MATERIAL SPEC. N/A	PREPARED HEMMER	12/18/84	C	77820
	CHECKED KELLER	2/18/85		
PROCESS SPEC. SEE NOTE 1	APPROVED HEMMER	2/6/85		
	APPROVED DAVIS	2/18/85		
	1ST PART NO.		SCALE	WT.
			10/1	
			REF	21-33191-530
			SHEET	N/A