

74500-178		REVISIONS		
ZONE	LTR	DESCRIPTION	DATE	APPROVED
✓	B	(CLII) RELOC COLOR BAND IDENT; PARTS LIST, NOTE 3, TITLE ECN:CNR	7/18/83 EDWARDS	

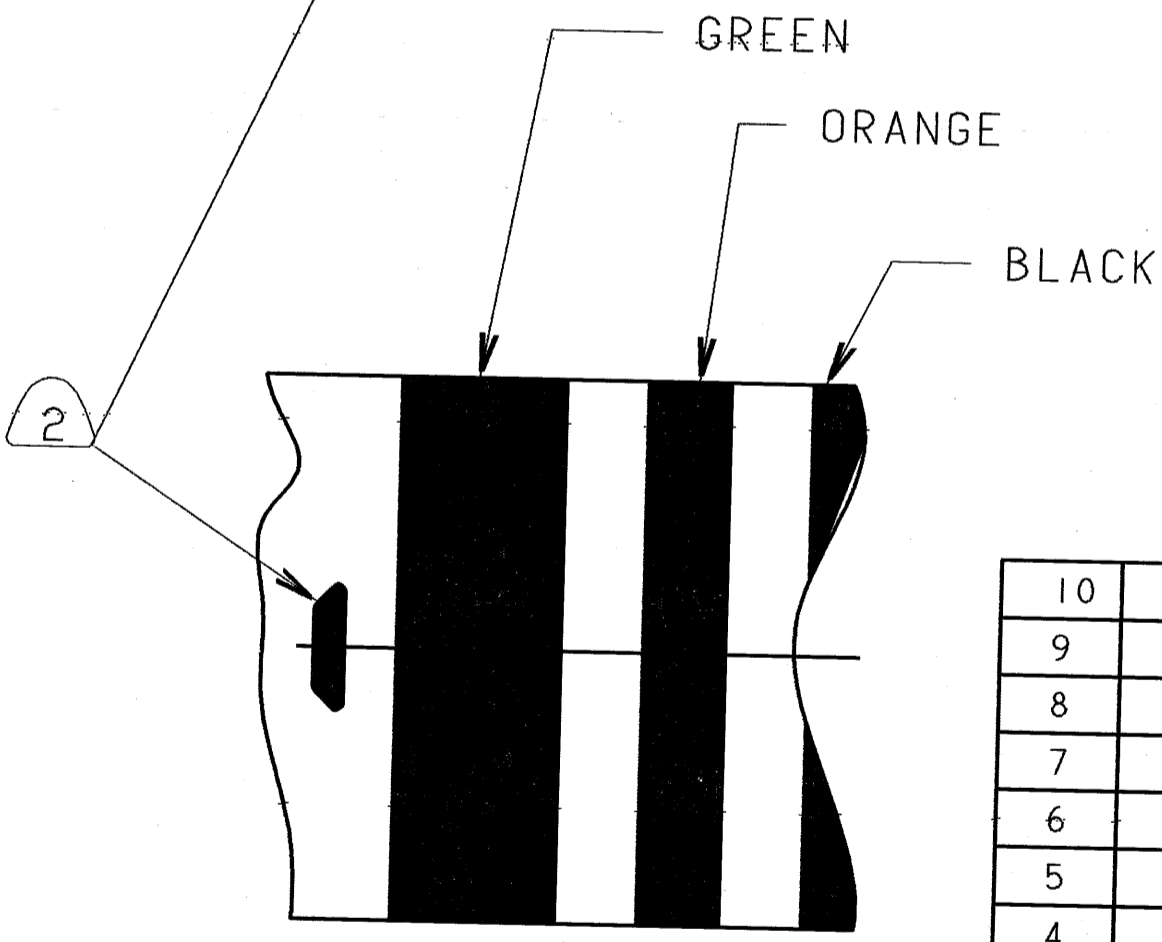
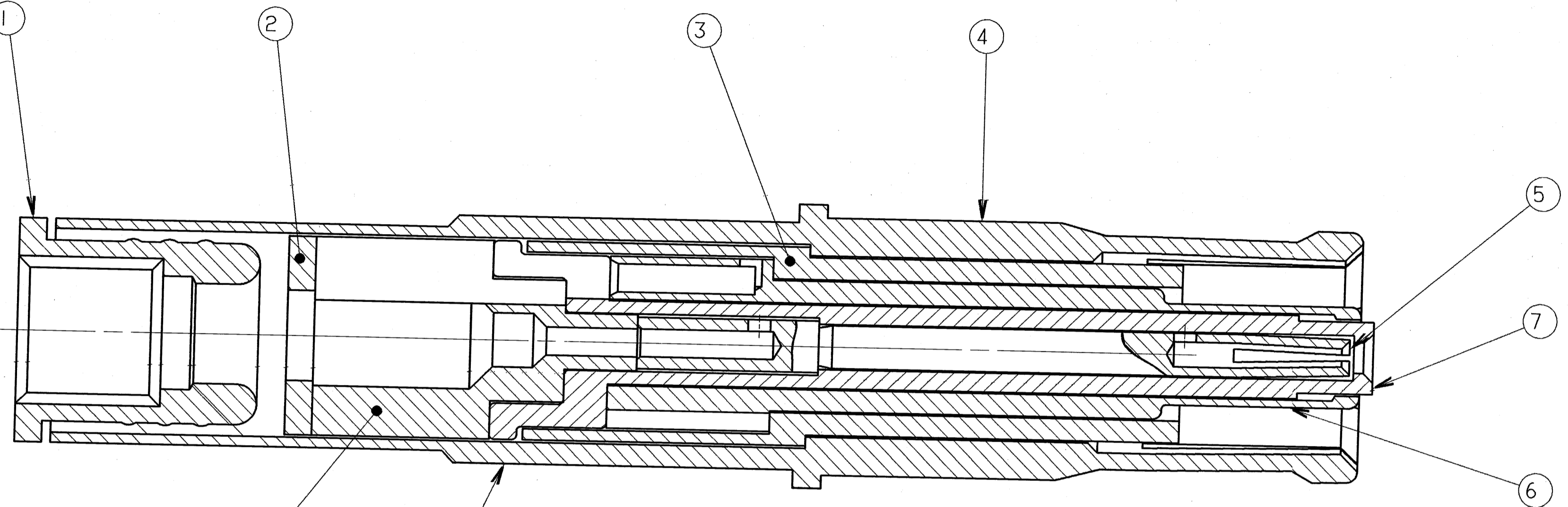

6. MEETS THE REQUIREMENTS OF M39029/91-530.
5. INDICATED ITEM NOT ILLUSTRATED.
4. CONTACT WILL ACCOMMODATE MI7/176-00002 CABLE.
3. DRAWING ILLUSTRATES FINAL ASSEMBLY. COMPLETE INSTALLATION INSTRUCTIONS (F/N 10). PACKED WITH EACH ASSEMBLY. PACKAGE PER PRODUCTION PROCESS SHEET.
2. BLACK INK STAMP TRADEMARK 9-6700 TYPE IV, PER 9-7530 IN APPROXIMATE POSITION SHOWN. TRADEMARK MAY BE SOLID AS SHOWN.
1. PROCESS SPEC:
TEST 9-5272-28
SPECIAL CONTROL 9-6000-4
PROCESS SHEET CONTROL 9-4796
9-6700, 9-7530

FIND NO.	QTY REQD.	FSCM NO.	PART NUMBER	DESCRIPTION	NOTE REF
10	1		21-33319	INSTALLATION INSTRUCTIONS	5
9	1		21-33310-1	SLEEVE	5
8	1		21-33305-1	INSULATOR	
7	1		21-33308-1	INSULATOR	
6	1		21-33314-15	CONTACT	
5	1		21-33315-15	CONTACT	
4	1		21-33311-15	CONTACT	
3	1		21-33307-1	INSULATOR	
2	1		21-33304-1	SPACER	
1	1		21-33303-15	BUSHING	

UNLESS OTHERWISE SPECIFIED		PARTS LIST	
LINEAR DIMENSIONS ARE IN INCHES.		SIGNATURES	
TOLERANCES: .XXX±.010,		DATES	
.XX ±.03, .X ±.1, ANGLES ±2°.		PREPARED EDWARDS 6/9/83 CHECKED Keller 8/30/83 MAJORITY M. Williams 8-30-83 APPROVED Demmer 8-26-83 APPROVED Al Davis 8-26-83	
OTHER STANDARDS PER 9-3800		THE BENDIX CORPORATION ELECTRICAL COMPONENTS DIVISION SIDNEY, NEW YORK 13838	
AND DOD-D-1000. NOTE REF XX		CONTACT, SOCKET, CONCENTRIC TWINAX SIZE 8	
GENERAL USE	PROCESS SPEC. SEE NOTE 1	SIZE C	FSCM NO. 77820
NEXT ASSEMBLY		SCALE 10/1	WT.
COMPUTER GENERATED DRAWING.		21-33191-530	
		REF L-38185-230	
		SHEET	

21-33191-530

B

A