

4

3

2

1

REVISIONS				
ZONE	LTR	DESCRIPTION	DATE	APPROVED
—	A	INITIAL RELEASE NUM: 70089-326		
	B	(CL I) SEE CHG SHEET ECN: 80174	8-8-90 grosh	<i>g</i>
	C	(CL II) UPDATED 9-4796-1 TO -2/ BENDIX TO AMPHENOL ECN: B1418	4-12-11 JONES	

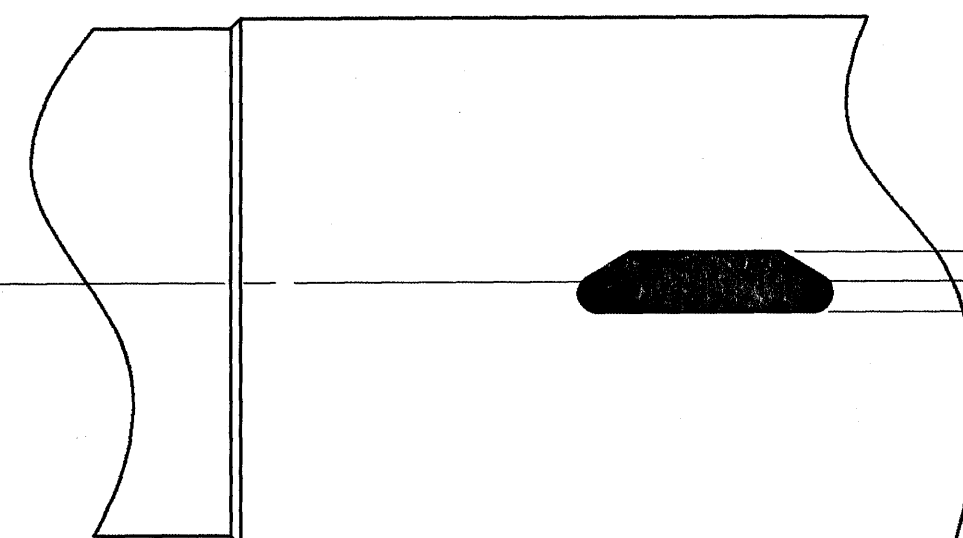

.031 ± .002

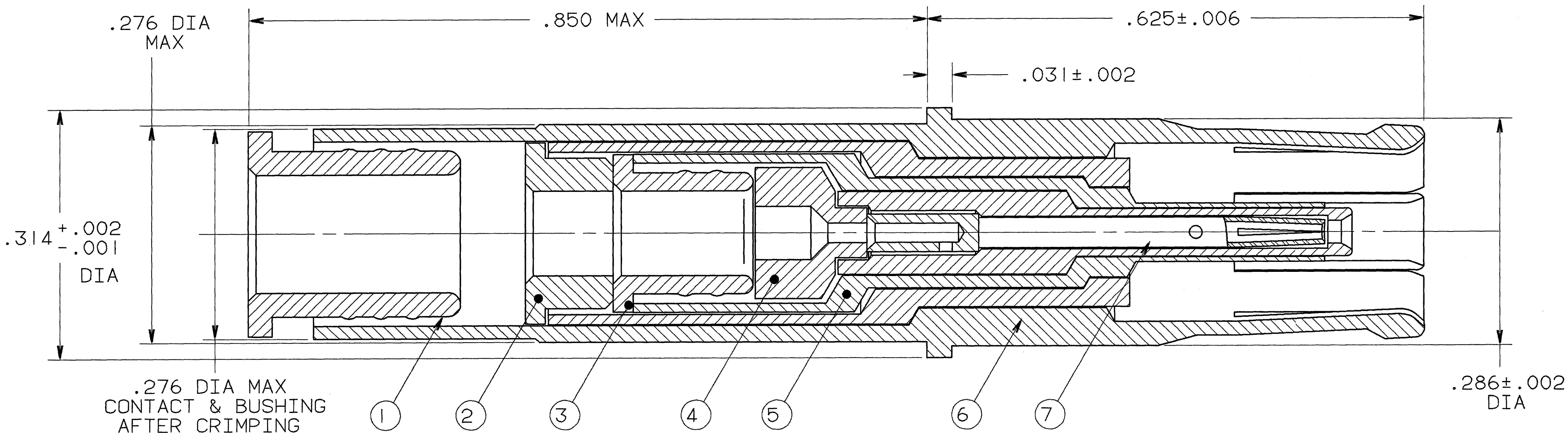

8. MATES WITH ANY PIN CONTACT IN 21-33198 PART NUMBER SERIES.
7. HANDLE CAREFULLY TO AVOID DISTORTION.
6. FINISH ON ALL METAL PARTS:
.000050 MIN GOLD, (KNOOP HARDNESS 130-200), OVER NICKEL UNDERPLATE.
5. INDICATED ITEM IS NOT ILLUSTRATED.
4. CONTACT WILL ACCOMMODATE TRIAXIAL CABLE MCAIR PART NUMBER 5M2397-001 OR 5M2397-002.
3. DRAWING ILLUSTRATES FINAL ASSEMBLY. COMPLETE INSTALLATION INSTRUCTIONS, (F/N 8), ARE PACKED WITH EACH ASSEMBLY. PACKAGE PER PRODUCTION PROCESS SHEET.
2. IF NOT PREVIOUSLY STAMPED, BLACK INK STAMP TRADEMARK 9-6700 TYPE IV, PER 9-7530 OR 9-3856-5, IN APPROXIMATE POSITION SHOWN; DIRECTION OPTIONAL. TRADEMARK MAY BE SOLID AS SHOWN.
1. PROCESS SPEC:
TEST 9-5272-29,
PROCESS SHEET CONTROL 9-4796-2,
9-6700, 9-7530, 9-3856-5.

NOTES:

THE USE OF THIS DOCUMENT IS UNLIMITED.
HOWEVER, DOCUMENTS REFERENCED HEREON
MAY CONTAIN LIMITED RIGHTS DATA.

N/A
N/A
NEXT ASSEMBLY

COMPANY ID: 9
CODED/MS/CUST: N
INTERNAL: N
LOTNO: N
DATE CODE: N
SEE PRINT: Y

UNLESS OTHERWISE SPECIFIED
LINEAR DIMENSIONS ARE IN
INCHES.
TOLERANCES: .XXX ± .010,
.XX ± .03, .X ± .1,
ANGLES ± 2°.
OTHER STANDARDS PER 9-3800
AND DOD-D-1000.
NOTE REF. = *XX*

FIND NO.	QTY REQD.	FSCM NO.	PART NUMBER	DESCRIPTION	NOTE REF.
9	1		21-33321-5	PIGGYBACK GROMMET SEAL	5
8	1		21-33855-3	INSTALLATION INSTRUCTIONS	3,5
7	1		21-33337-55	CONTACT	7
6	1		21-33335-45	CONTACT	
5	1		21-33334-45	CONTACT	
4	1		21-1381-108	INSULATOR	
3	1		21-33303-425	BUSHING	7
2	1		21-1381-104	INSULATOR	
1	1		21-33303-125	BUSHING	

SPECIFICATIONS			PARTS LIST		REV. C
MATERIAL SPEC.	SIGNATURES	DATES	SIZE	FSCM NO.	
N/A	PREPARED: A. PRESCOTT CHECKED: <i>Lemmer</i> MATERIAL: <i>B. Dawns</i> APPROVED: <i>Lemmer</i> APPROVED: <i>al Davis</i>	8/29/89 11-8-89 11-8-89 13-Nov-89	C	77820	
PROCESS SPEC. SEE NOTE 1	AMPHENOL CORPORATION 40-60 DELAWARE AVENUE SIDNEY, N.Y.		21-33197-3		
SCALE 10/1			WT.	REF 21-33197	SHEET N/A

21-33197-3

B

A