

REV. B		SHEET 1 OF 1		21-033384-151	
REVISIONS					
LTR	DESCRIPTION			DATE	
A	INITIAL RELEASE				
B	(CLII) SEE ENG CHG ECN: A2020			DJSMITH 1/18/07	

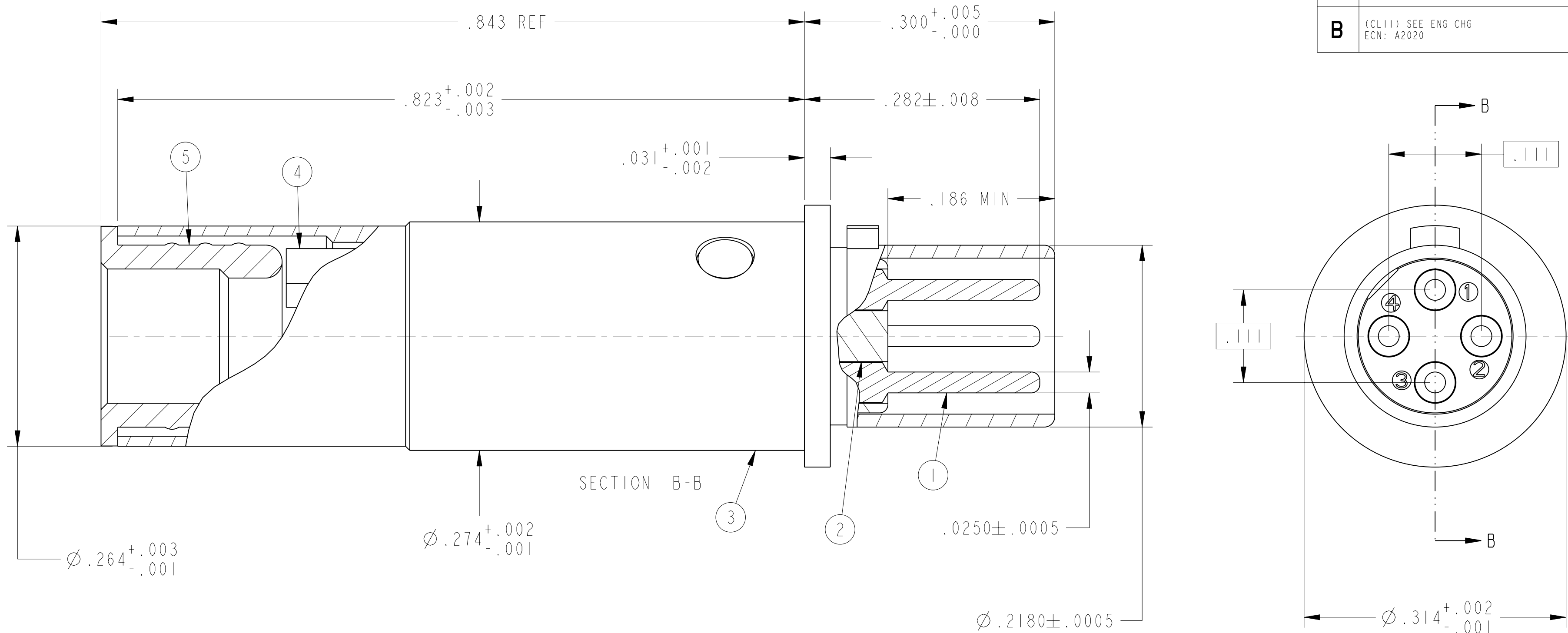

- MATES WITH M38999 QUADRAX SOCKETS 21-33385-().
- CRIMPING TOOLS:
 OUTER CONTACT- M22520/5-01 TOOL, M22520/5-45 DIE SET (HEX CLOSURE A)
 INNER CONTACTS- M22520/2-01 TOOL, DANIELS K709 (M22520/2-37) POSITIONER
- TERMINATES QUADRAX CABLE DRAKA FILECA F4704-6 (100 OHM) OR EQUIVALENT.
- DRAWING ILLUSTRATES FINAL ASSEMBLY. CONTACT COMPONENTS ARE SHIPPED UNASSEMBLED. INSTALLATION INSTRUCTIONS & PIGGYBACK GROMMET SEAL (NOT ILLUSTRATED) ARE PACKAGED WITH EACH ASSEMBLY. PACKAGE PER PRODUCTION PROCESS SHEET.
- MATERIALS:
 OUTER & INNER CONTACTS- BERYLLIUM COPPER PER ASTM-B-196
 SHIELD FERRULE- BRASS PER ASTM B453 OR EQUIVALENT
 FRONT INSULATOR & SPACER INSULATOR- TFE RESIN PER AMS 3651 OR EQUIVALENT
- FINISH:
 GOLD PLATED PER MIL-G-45204 TYPE II, GRADE C, CLASS I (.000050 MIN)
 OVER NICKEL PLATE PER QQ-N-290 (.000050 MIN).
- CONTACTS MEET THE ENVELOPE DIMENSIONAL REQUIREMENTS OF M39029/90.

NOTES:

THE USE OF THIS DOCUMENT IS UNLIMITED. HOWEVER, DOCUMENTS REFERENCED HEREON MAY CONTAIN LIMITED RIGHTS DATA.

N/A
NEXT ASSEMBLY

PRO/ENGINEER INFORMATION
Pro/e Model Used:
21-033384-151.ASSEM
Drawing Name:
21-033384-151

UNLESS OTHERWISE SPECIFIED

LINEAR DIMENSIONS ARE IN INCHES
TOLERANCES:
 .XXXX = ±.0005 ANGLES= ±2°
 .XXX = ±.010
 .XX = ±.03
 .X = ±.1

DIM. & TOL. PER ASME Y14.5M;
 DRM PER MIL-DTL-31000;
 OTHER Amphenol Stds. PER 9-3800

LEGENDS:
 = FLAG NOTE CALL OUT REFERENCE ONLY

SPECIFICATIONS

MATERIAL SPEC.
N/A

PROCESS SPEC.
N/A

POS	QTY	PART NUMBER	DESCRIPTION	NOTE
7	1	L-2119-AW	INSTALLATION INSTRUCTIONS	4
6	1	21-033321-005	PIGGYBACK GROMMET SEAL	4
5	1	21-033384-066	SHIELD FERRULE	
4	1	21-033382-005 OR 21-033382-025	SPACER INSULATOR	
3	1	21-033384-044	OUTER CONTACT	
2	1	21-033384-043	FRONT INSULATOR	
1	4	21-033384-022	INNER CONTACT	

APPROVALS	DATE
PREPARED BY DJSMITH	
ENGINEER IN CHARGE LRATCHFORD	30-0c1-06
DESIGN MANAGER ADAVIS	
DESIGN ACTIVITY GROUP MIL AERO	

THIRD ANGLE PROJECTION

PARTS LIST

AMPHENOL CORPORATION
 40-60 DELAWARE AVENUE
 SIDNEY, NY. 13858

**CONTACT, PIN, QUADRAX,
 ELECTRICAL CONNECTOR,
 TYPE M38999-21**

SIZE C	CAGE CODE 77820	DOCUMENT NO. 21-033384-151	REV. B
SCALE: 10.0		REF. 21-33384-21	SHEET 1 OF 1