

REV. A	SHEET 1 OF 1	DOCUMENT NO. 21-033384-231
REVISIONS		
LTR	DESCRIPTION	DATE
A	INITIAL RELEASE	

21-033384-231

SHEET 1 OF 1

REV. A

C

B

A

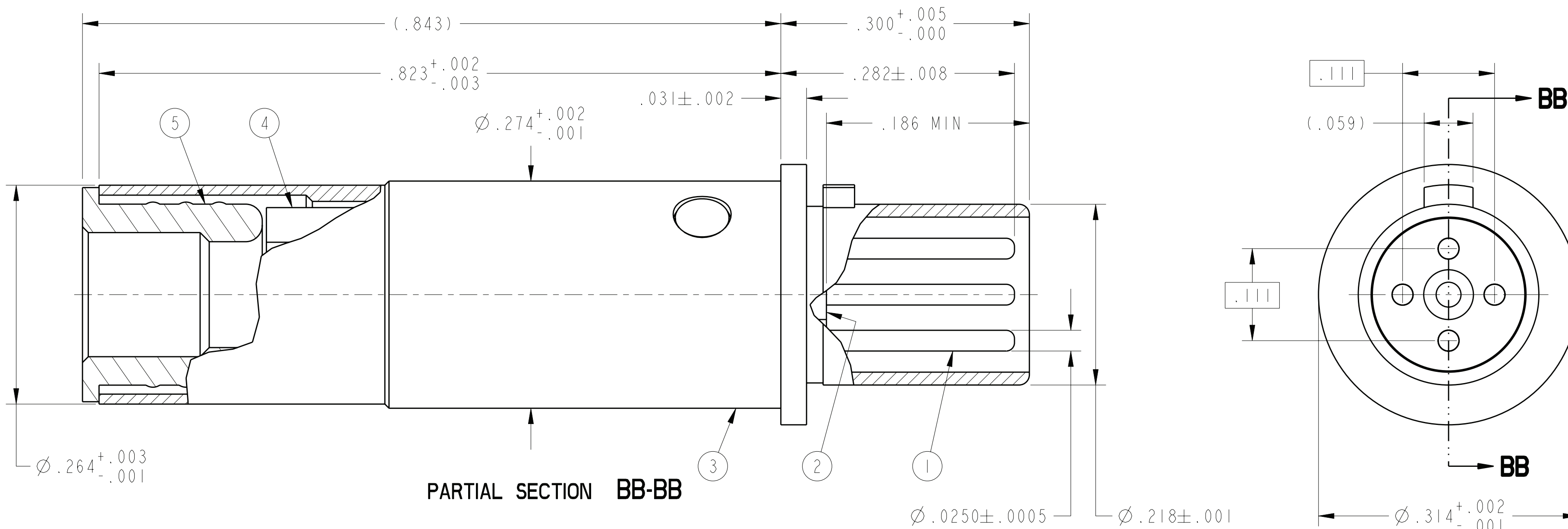

PARTIAL SECTION BB-BB

- MATES WITH M38999 QUADRAX SOCKETS 21-033385-( ).
- CRIMPING TOOLS:  
 OUTER CONTACT- M22520/5-01 TOOL, M22520/5-45 DIE SET (HEX CLOSURE A)  
 INNER CONTACTS- M22520/2-01 TOOL, DANIELS K709 (M22520/2-37) POSITIONER
- TERMINATES QUADRAX CABLE RCN8487-1 OR JSFY18-1 (110 OHM) OR EQUIVALENT.
- DRAWING ILLUSTRATES FINAL ASSEMBLY. CONTACT COMPONENTS ARE SHIPPED UNASSEMBLED. INSTALLATION INSTRUCTIONS & PIGGYBACK GROMMET SEAL (NOT ILLUSTRATED) ARE PACKAGED WITH EACH ASSEMBLY. PACKAGE PER PRODUCTION PROCESS SHEET.
- MATERIALS:  
 OUTER & INNER CONTACTS- BERYLLIUM COPPER PER ASTM-B-196  
 SHIELD FERRULE- BRASS PER ASTM B453 OR EQUIVALENT  
 FRONT INSULATOR & SPACER INSULATOR- TFE RESIN PER AMS 3651 OR EQUIVALENT
- FINISH:  
 GOLD PLATED PER MIL-G-45204 TYPE II, GRADE C, CLASS I (.000050 MIN)  
 OVER NICKEL PLATE PER QQ-N-290 (.000050 MIN).
- CONTACTS MEET THE ENVELOPE DIMENSIONAL REQUIREMENTS OF M39029/90.

NOTES:

THE USE OF THIS DOCUMENT IS UNLIMITED. HOWEVER, DOCUMENTS REFERENCED HEREON MAY CONTAIN LIMITED RIGHTS DATA.

N/A  
NEXT ASSEMBLY

PRO/ENGINEER INFORMATION  
Pro/e Model Used:  
21-033384-231.ASSEM  
Drawing Name:  
21-033384-231

UNLESS OTHERWISE SPECIFIED	SPECIFICATIONS
LINEAR DIMENSIONS ARE IN INCHES TOLERANCES: .XXXX = ±.0005 ANGLES= ±2° .XXX = ±.010 .XX = ±.03 .X = ±.1	MATERIAL SPEC. N/A
DIM. & TOL. PER ASME Y14.5M; DRM PER MIL-DTL-31000; OTHER Amphenol Stds. PER 9-3800	PROCESS SPEC. N/A
LEGENDS: = FLAG NOTE CALL OUT REFERENCE ONLY	

POS	QTY	PART NUMBER	DESCRIPTION	NOTE
7	1	L-2119-CR	INSTALLATION INSTRUCTIONS	4
6	1	21-033321-005	PIGGYBACK GROMMET SEAL	4
5	1	21-033384-086	SHIELD FERRULE	
4	1	21-033382-005 OR 21-033382-025	SPACER INSULATOR	
3	1	21-033384-044	OUTER CONTACT	
2	1	21-033384-053	FRONT INSULATOR	
1	4	21-033384-032	INNER CONTACT	

APPROVALS		DATE	PARTS LIST	
PREPARED BY	RATCHFORD	14-Jan-09	<b>AMPHENOL CORPORATION</b> 40-60 DELAWARE AVENUE SIDNEY, NY. 13858 <b>CONTACT, PIN, QUADRAX,          ELECTRICAL CONNECTOR,          TYPE M38999 I &amp; III, IEEE 1394B</b>	
ENGINEER IN CHARGE	RATCHFORD			
DESIGN MANAGER	SHEPLER			
DESIGN ACTIVITY GROUP	MIL-AERO DEVELOP			
THIRD ANGLE PROJECTION			SIZE	CAGE CODE
			C	77820
			DOCUMENT NO.	REV.
			21-033384-231	A
			SCALE: 10:0	SHEET 1 OF 1

FORMAT: C-U-E-I

21-033384-231

SHEET 1 OF 1

REV. A

RELEASE STATE WIP

SHEET 1 OF 1

21-033384-231