

REV. A	SHEET 1 OF 1	DOCUMENT NO. 21-033387-131
REVISIONS M		
LTR	DESCRIPTION	DATE
A	INITIAL RELEASE	---

21-033387-131

SHEET 1 OF 1

REV. A

C

B

A

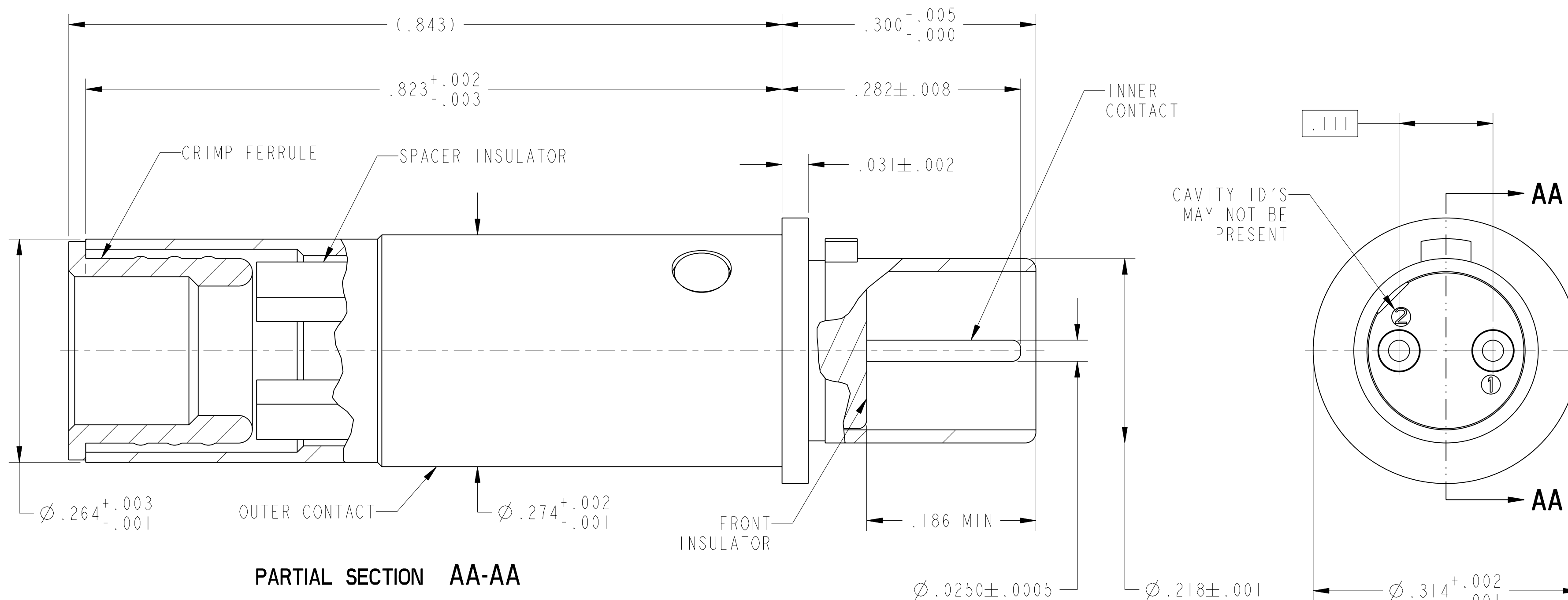

PARTIAL SECTION AA-AA

- MATES WITH M38999 DIFFERENTIAL TWINAX SOCKETS 21-033388-().
- CRIMPING TOOLS:
 OUTER CONTACT- M22520/5-01 TOOL, M22520/5-45 DIE SET (HEX CLOSURE A)
 INNER CONTACTS- M22520/2-01 TOOL, DANIELS K709 (M22520/2-37) POSITIONER
- TERMINATES TWINAX CABLE CAN24TDT120 (120 OHM) OR EQUIVALENT.
- DRAWING ILLUSTRATES FINAL ASSEMBLY. CONTACT COMPONENTS ARE SHIPPED UNASSEMBLED. INSTALLATION INSTRUCTIONS & PIGGYBACK GROMMET SEAL (NOT ILLUSTRATED) ARE PACKAGED WITH EACH ASSEMBLY. PACKAGE PER PRODUCTION PROCESS SHEET.
- MATERIALS:
 OUTER & INNER CONTACTS- BERYLLIUM COPPER PER ASTM-B-196
 SHIELD FERRULE- BRASS PER ASTM B453 OR QQ-B-626
 FRONT & SPACER INSULATORS- PFA PER ASTM D 3307 OR PTFE PER ASTM D 1710
- FINISH:
 GOLD PLATED PER MIL-G-45204 TYPE II, GRADE C, CLASS I (.000050 MIN)
 OVER NICKEL PLATE PER QQ-N-290 (.000050 MIN).
- CONTACTS MEET THE ENVELOPE DIMENSIONAL REQUIREMENTS OF M39029/90.

NOTES:

THE USE OF THIS DOCUMENT IS UNLIMITED. HOWEVER, DOCUMENTS REFERENCED HEREON MAY CONTAIN LIMITED RIGHTS DATA.

RELEASED / Jan . 23 2015, 9:30:04 AM

DOCUMENT NO. 21-033387-131 SHEET 1 OF 1 REV. A

N/A

NEXT ASSEMBLY

PRO/ENGINEER INFORMATION

Pro/e Model Used:

21-033387-131.ASSEM

Drawing Name:

21-033387-131

UNLESS OTHERWISE SPECIFIED	SPECIFICATIONS	POS	QTY	PART NUMBER	DESCRIPTION	NOTE
LINEAR DIMENSIONS ARE IN INCHES TOLERANCES: .XXXX = ±.0005 ANGLES= ±2° .XXX = ±.010 .XX = ±.03 .X = ±.1 DIM. & TOL. PER ASME Y14.5M; DRM PER MIL-DTL-31000; OTHER Amphenol Stds. PER 9-3800 LEGENDS: =FLAG NOTE CALL OUT REFERENCE ONLY	MATERIAL SPEC.	PARTS LIST				
	N/A	AMPHENOL CORPORATION 40-60 DELAWARE AVENUE SIDNEY, N.Y. 13858 CONTACT, PIN, DIFFERENTIAL TWINAX, TYPE: M38999 TYPE I & III				
PROCESS SPEC.	N/A	APPROVALS PREPARED BY D. PHILLIPS ENGINEER IN CHARGE D. PHILLIPS 07-Jan-15 DESIGN MANAGER E. HICKEY DESIGN ACTIVITY GROUP C-1 THIRD ANGLE PROJECTION				
		SIZE	CAGE CODE	DOCUMENT NO.	REV.	
		C	77820	21-033387-131	A	
		SCALE: 10.0	REF. 21-33387-21	SHEET 1 OF 1		

VISION 2

REVISION A

Eng PDM Information For Reference Only

REV. A

SHEET 1 OF 1

21-033387-131