

REV. B		SHEET 1 OF 1		DOCUMENT NO. 21-033388-071	
REVISIONS					
LTR	DESCRIPTION			DATE	
A	INITIAL RELEASE			28-Jun-2010	
B	(CL 1) SEE CHANGE NOTICE. ECN: B6687-0000			--	

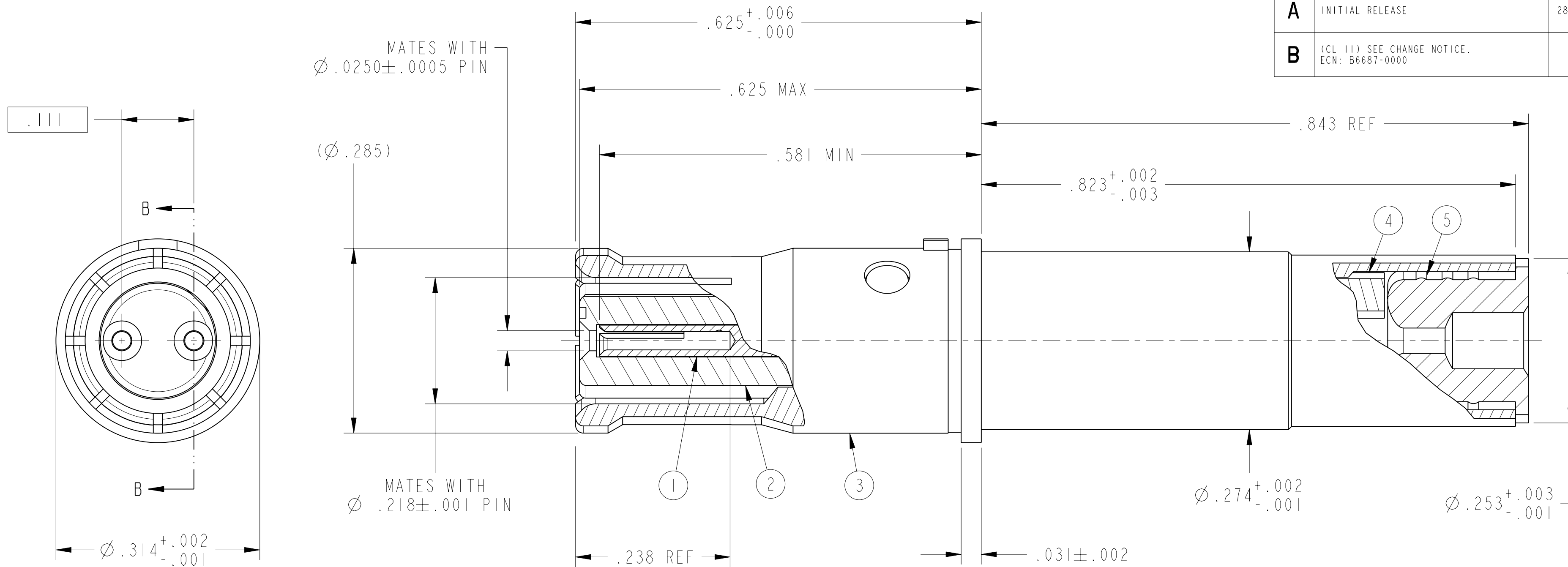

SECTION B-B

7. MATES WITH M38999 DIFFERENTIAL TWINAX PINS 21-33387-().
6. CRIMPING TOOLS:
 OUTER CONTACT- M22520/5-01 TOOL, M22520/5-45 DIE SET (HEX CLOSURE A)
 INNER CONTACTS- M22520/2-01 TOOL, DANIELS K709 (M22520/2-37) POSITIONER
5. TERMINATES TWINAX CABLE RAYCHEM 0026A0024 (100 OHM) OR EQUIVALENT.
4. DRAWING ILLUSTRATES FINAL ASSEMBLY. CONTACT COMPONENTS ARE SHIPPED UNASSEMBLED. INSTALLATION INSTRUCTIONS & PIGGYBACK GROMMET SEAL (NOT ILLUSTRATED) ARE PACKAGED WITH EACH ASSEMBLY. PACKAGE PER PRODUCTION PROCESS SHEET.
3. MATERIALS:
 OUTER & INNER CONTACTS- BERYLLIUM COPPER PER ASTM-B-196
 SHIELD FERRULE- BRASS PER ASTM B453 OR EQUIVALENT
 FRONT INSULATOR & SPACER INSULATOR- TFE RESIN PER AMS 3651 OR EQUIVALENT
2. FINISH:
 GOLD PLATED IN ACCORDANCE WITH SAE AS39029
 OVER NICKEL PLATE PER QQ-N-290 (.000050 MIN).
1. CONTACTS MEET THE ENVELOPE DIMENSIONAL REQUIREMENTS OF M39029/91.

NOTES:

THE USE OF THIS DOCUMENT IS UNLIMITED. HOWEVER, DOCUMENTS REFERENCED HEREON MAY CONTAIN LIMITED RIGHTS DATA.

N/A
NEXT ASSEMBLY

PRO/ENGINEER INFORMATION
 Pro/e Model Used:
 21-033388-071.ASSEM
 Drawing Name:
 21-033388-071

UNLESS OTHERWISE SPECIFIED
 LINEAR DIMENSIONS ARE IN INCHES
 TOLERANCES:
 .XXXX = ±.0005 ANGLES= ±2°
 .XXX = ±.010
 .XX = ±.03
 .X = ±.1
 DIM. & TOL. PER ASME Y14.5M;
 DRM PER MIL-DTL-31000;
 OTHER Amphenol Stds. PER 9-3800
 LEGENDS:
 =FLAG NOTE CALL OUT REFERENCE ONLY

SPECIFICATIONS

MATERIAL SPEC.
N/A

PROCESS SPEC.

N/A

POS	QTY	PART NUMBER	DESCRIPTION	NOTE
7	1	L-2119-BJ	INSTALLATION INSTRUCTIONS	4
6	1	21-033321-005	PIGGYBACK GROMMET SEAL	4
5	1	21-033384-046	SHIELD FERRULE	
4	1	21-033382-005 OR 21-033382-025	SPACER INSULATOR	
3	1	21-033385-044	OUTER CONTACT	
2	1	21-033388-043	FRONT INSULATOR	
1	2	21-033385-022	INNER CONTACT	

PARTS LIST

APPROVALS	DATE
PREPARED BY RATCHFORD	21-Jun-10
ENGINEER IN CHARGE RATCHFORD	
DESIGN MANAGER SHEPLER	
DESIGN ACTIVITY GROUP MIL AERO	

AMPHENOL CORPORATION
 40-60 DELAWARE AVENUE
 SIDNEY, N.Y. 13858

**CONTACT, SOCKET,
 DIFFERENTIAL TWINAX,
 TYPE M38999 I & III**

SIZE C	CAGE CODE 77820	DOCUMENT NO. 21-033388-071	REV. B
SCALE: 8.0		REF. 21-33388-41	SHEET 1 OF 1