

REV. B		SHEET 1 OF 1		DOCUMENT NO. 21-033441-001	
REVISIONS					
LTR	DESCRIPTION	DATE			
A	INITIAL RELEASE	9-15-06			
B	(CL 11) SEE CHG NOTICE ECN: A8689-0000	6/15/10			

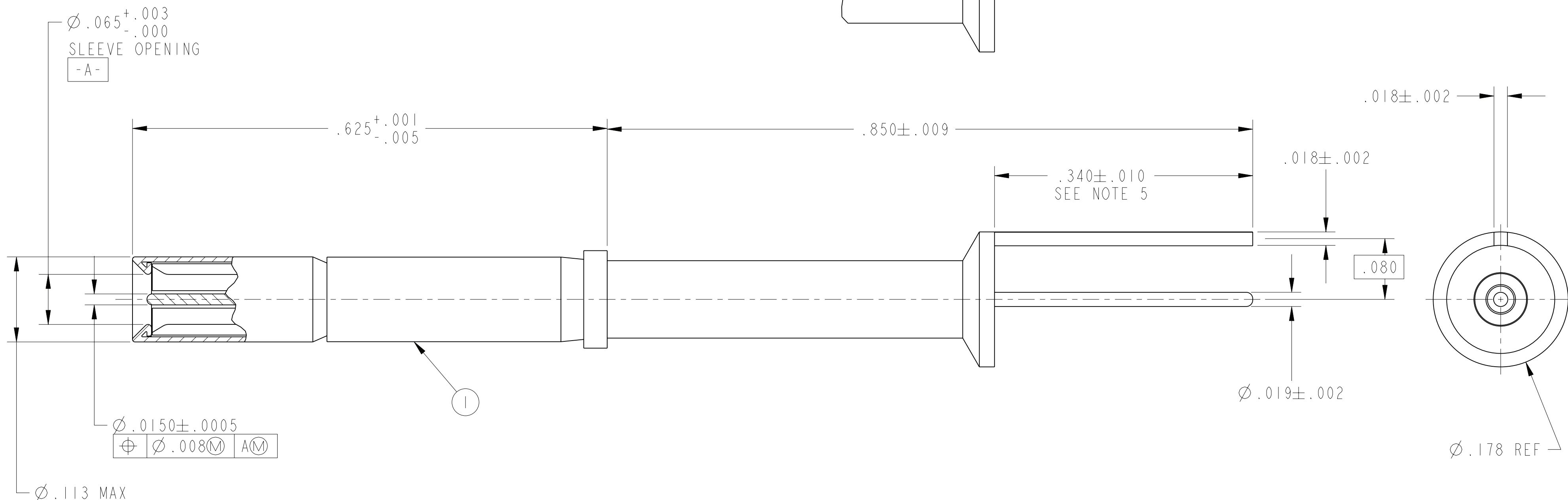
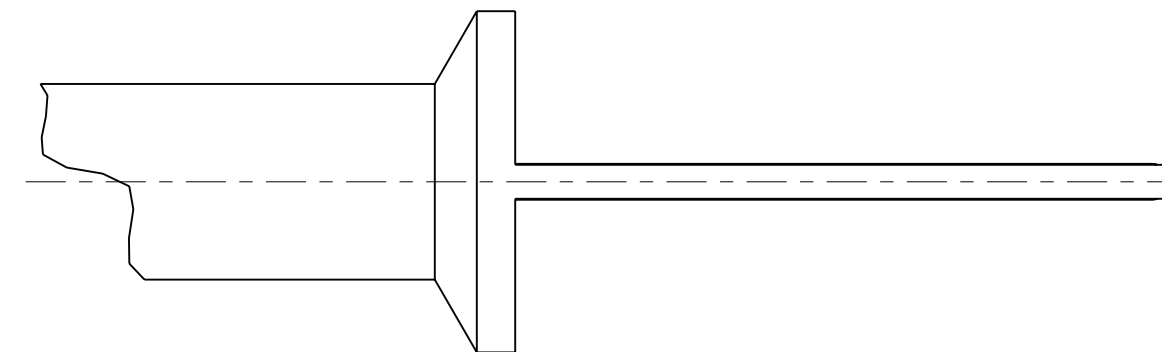

- 7. MATES WITH COAXIAL PIN CONTACTS 21-33122-56().
- 6. CLEANING OF PARTS IN CHLORINATED SOLVENTS IS NOT PERMISSIBLE.
- 5. INDICATED AREA SHALL BE CAPABLE OF MEETING THE SOLDERABILITY REQUIREMENTS OF MIL-STD-202 METHOD 208.
- 4. ALL DIMENSIONS ARE AFTER PLATING.
- 3. MATERIALS: CONTACTS- BERYLLIUM COPPER PER ASTM B196, ALLOY C17300, TEMPER TD04
INSULATORS- TFE PER AMS 3651 OR POLYAMIDEIMIDE (TORLON 4203L) OR POLYETHERIMIDE (ULTEM 1000)
- 2. PACKAGE PER PRODUCTION PROCESS SHEET.
- 1. FINISH: GOLD PLATED PER MIL-G-45204 TYPE II, GRADE C, CLASS I OVER NICKEL PLATE PER QQ-N-290 (.000050 THICK MIN).

NOTES:

THE USE OF THIS DOCUMENT IS UNLIMITED. HOWEVER, DOCUMENTS REFERENCED HEREON MAY CONTAIN LIMITED RIGHTS DATA.

N/A
NEXT ASSEMBLY

PRO/ENGINEER INFORMATION
 Pro/e Model Used:
 21-033441-001.ASSEM
 Drawing Name:
 21-033441-001

UNLESS OTHERWISE SPECIFIED	SPECIFICATIONS	POS	QTY	PART NUMBER	DESCRIPTION	NOTE
LINEAR DIMENSIONS ARE IN INCHES TOLERANCES: .XXXX = ±.0005 ANGLES= ±2° .XXX = ±.010 .XX = ±.03 .X = ±.1 DIM. & TOL. PER ASME Y14.5M; DRM PER MIL-DTL-31000; OTHER Amphenol Stds. PER 9-3800 LEGENDS: =FLAG NOTE CALL OUT REFERENCE ONLY	MATERIAL SPEC.	PARTS LIST				
	N/A	APPROVALS PREPARED BY RATCHFORD ENGINEER IN CHARGE RATCHFORD DESIGN MANAGER H. JOHNSON DESIGN ACTIVITY GROUP MIL-AERO DATE 15-Sep-06 AMPHENOL CORPORATION 40-60 DELAWARE AVENUE SIDNEY, N.Y. 13858 CONTACT ASSEMBLY, SIZE 16 COAX, TYPE TV PCB				
PROCESS SPEC.	N/A	THIRD ANGLE PROJECTION 				
		SIZE	CAGE CODE	DOCUMENT NO.	REV.	
		C	77820	21-033441-001	B	
		SCALE: 2.0	REF 21-33857-3	SHEET 1 OF 1		