

REV. A	SHEET 1 OF 1	DOCUMENT NO. 21-033450-011
REVISIONS M		
LTR	DESCRIPTION	DATE
A	INITIAL RELEASE	---

21-033450-011

SHEET 1 OF 1

REV. A

C

B

A

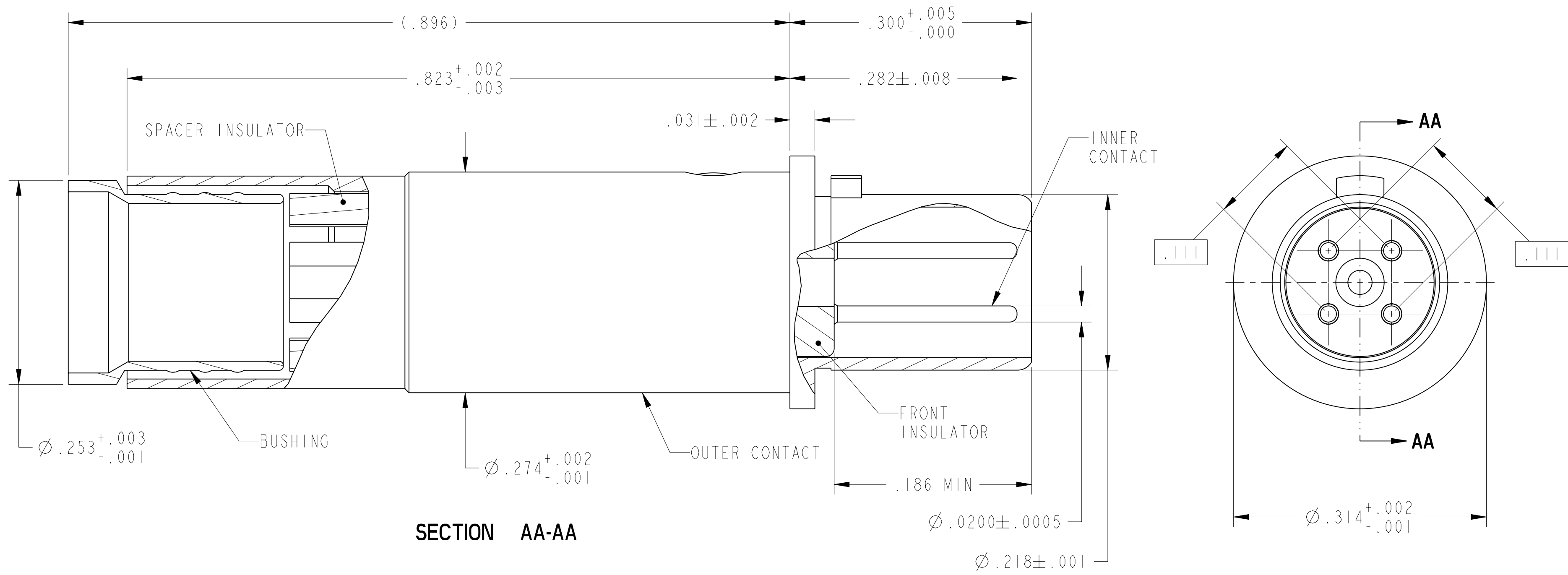

SECTION AA-AA

- MATES WITH M38999 QUADRAX SOCKETS 21-033451-().
- CRIMPING TOOLS:
 OUTER CONTACT- M22520/5-01 TOOL, M22520/5-45 DIE SET (HEX CLOSURE A)
 INNER CONTACTS- M22520/2-01 TOOL, DANIELS K709 (M22520/2-37) POSITIONER
- TERMINATES QUADRAX CABLE TENSOLITE 26473/02006X-4(LD) (150 OHM) OR EQUIVALENT.
- DRAWING ILLUSTRATES FINAL ASSEMBLY. CONTACT COMPONENTS ARE SHIPPED UNASSEMBLED. INSTALLATION INSTRUCTIONS & PIGGYBACK GROMMET SEAL (NOT ILLUSTRATED) ARE PACKAGED WITH EACH ASSEMBLY. PACKAGE PER PRODUCTION PROCESS SHEET.
- MATERIALS:
 OUTER & INNER CONTACTS- BERYLLIUM COPPER PER ASTM-B-196
 SHIELD FERRULE- BRASS PER ASTM B453 OR QQ-B-626
 FRONT INSULATOR & SPACER INSULATOR- TFE RESIN PER ASTM 3651
- FINISH:
 GOLD PLATED PER MIL-G-45204 TYPE II, GRADE C, CLASS I (.000050 MIN)
 OVER NICKEL PLATE PER QQ-N-290 (.000050 MIN).
- CONTACTS MEET THE ENVELOPE DIMENSIONAL REQUIREMENTS OF M39029/90.

NOTES:

THE USE OF THIS DOCUMENT IS UNLIMITED. HOWEVER, DOCUMENTS REFERENCED HEREON MAY CONTAIN LIMITED RIGHTS DATA.

N/A NEXT ASSEMBLY

PRO/ENGINEER INFORMATION
Pro/e Model Used: 21-033450-011.ASSEM
Drawing Name: 21-033450-011

UNLESS OTHERWISE SPECIFIED	SPECIFICATIONS	POS	QTY	PART NUMBER	DESCRIPTION	NOTE																																												
LINEAR DIMENSIONS ARE IN INCHES TOLERANCES: .XXXX = ±.0005 ANGLES= ±2° .XXX = ±.010 .XX = ±.03 .X = ±.1 DIM. & TOL. PER ASME Y14.5M; DRM PER MIL-DTL-31000; OTHER Amphenol Stds. PER 9-3800 LEGENDS: =FLAG NOTE CALL OUT REFERENCE ONLY	MATERIAL SPEC.	<table border="1"> <tr> <th colspan="2">APPROVALS</th> <th>DATE</th> <th colspan="3">PARTS LIST</th> </tr> <tr> <td>PREPARED BY</td> <td>J. CARNEVALE</td> <td rowspan="4">15-Sep-14</td> <td colspan="3" rowspan="4"> AMPHENOL CORPORATION 40-60 DELAWARE AVENUE SIDNEY, N.Y. 13858 </td> </tr> <tr> <td>ENGINEER IN CHARGE</td> <td>D. PHILLIPS</td> </tr> <tr> <td>DESIGN MANAGER</td> <td>E. HICKEY</td> </tr> <tr> <td>DESIGN ACTIVITY GROUP</td> <td>CI</td> </tr> <tr> <td>THIRD ANGLE PROJECTION</td> <td colspan="5"> <table border="1"> <tr> <th>SIZE</th> <th>CAGE CODE</th> <th>DOCUMENT NO.</th> <th>REV.</th> </tr> <tr> <td>C</td> <td>77820</td> <td>21-033450-011</td> <td>A</td> </tr> </table> </td> </tr> <tr> <td>PROCESS SPEC.</td> <td colspan="5"> SCALE: 10:0 REF: 21-033450-001 SHEET 1 OF 1 </td> </tr> <tr> <td>N/A</td> <td colspan="5"></td> </tr> </table>					APPROVALS		DATE	PARTS LIST			PREPARED BY	J. CARNEVALE	15-Sep-14	AMPHENOL CORPORATION 40-60 DELAWARE AVENUE SIDNEY, N.Y. 13858			ENGINEER IN CHARGE	D. PHILLIPS	DESIGN MANAGER	E. HICKEY	DESIGN ACTIVITY GROUP	CI	THIRD ANGLE PROJECTION	<table border="1"> <tr> <th>SIZE</th> <th>CAGE CODE</th> <th>DOCUMENT NO.</th> <th>REV.</th> </tr> <tr> <td>C</td> <td>77820</td> <td>21-033450-011</td> <td>A</td> </tr> </table>					SIZE	CAGE CODE	DOCUMENT NO.	REV.	C	77820	21-033450-011	A	PROCESS SPEC.	SCALE: 10:0 REF: 21-033450-001 SHEET 1 OF 1					N/A					
	APPROVALS		DATE	PARTS LIST																																														
PREPARED BY	J. CARNEVALE	15-Sep-14	AMPHENOL CORPORATION 40-60 DELAWARE AVENUE SIDNEY, N.Y. 13858																																															
ENGINEER IN CHARGE	D. PHILLIPS																																																	
DESIGN MANAGER	E. HICKEY																																																	
DESIGN ACTIVITY GROUP	CI																																																	
THIRD ANGLE PROJECTION	<table border="1"> <tr> <th>SIZE</th> <th>CAGE CODE</th> <th>DOCUMENT NO.</th> <th>REV.</th> </tr> <tr> <td>C</td> <td>77820</td> <td>21-033450-011</td> <td>A</td> </tr> </table>					SIZE	CAGE CODE	DOCUMENT NO.	REV.	C	77820	21-033450-011	A																																					
SIZE	CAGE CODE	DOCUMENT NO.	REV.																																															
C	77820	21-033450-011	A																																															
PROCESS SPEC.	SCALE: 10:0 REF: 21-033450-001 SHEET 1 OF 1																																																	
N/A																																																		

FORMAT: C-U-E-I

RELEASED / Dec. 16 2014, 10:43:26 AM

21-033450-011

SHEET 1 OF 1

REV. A

REVISION 3

REVISION A

Eng PDM Information For Reference Only

REV. A

SHEET 1 OF 1

21-033450-011