

REV. D	SHEET 1 OF 1	DOCUMENT NO. 21-033457-001
REVISIONS		
LTR	DESCRIPTION	DATE
A	INITIAL RELEASE	10/01/2009
B	(CL I) SEE ECN B1360	06/10/2012
C	(CL II) SEE ECN B4285	27-Feb-2013
D	(CL II). SEE CHANGE NOTICE. ECN: B6687-0000	---

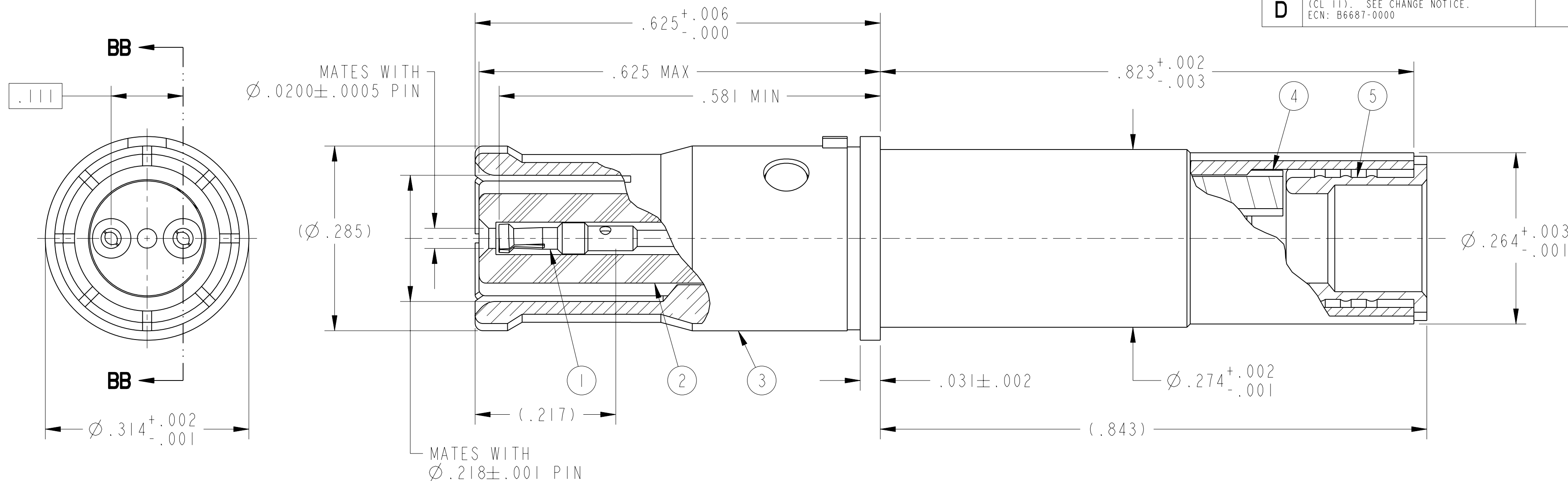

PARTIAL SECTION BB-BB

- MATES WITH M38999 DIFFERENTIAL TWINAX PINS 21-033456-().
- CRIMPING TOOLS:
 OUTER CONTACT- M22520/5-01 TOOL, M22520/5-45 DIE SET (HEX CLOSURE A)
 INNER CONTACTS- M22520/2-01 TOOL, DANIELS K709 (M22520/2-37) POSITIONER
- TERMINATES TWINAX CABLE TENSOLITE 26483/03071X-2(LD) (150 OHM) OR EQUIVALENT.
- DRAWING ILLUSTRATES FINAL ASSEMBLY. CONTACT COMPONENTS ARE SHIPPED UNASSEMBLED
 INSTALLATION INSTRUCTIONS & PIGGYBACK GROMMET SEAL (NOT ILLUSTRATED) ARE
 PACKAGED WITH EACH ASSEMBLY. PACKAGE PER PRODUCTION PROCESS SHEET.
- MATERIALS:
 OUTER & INNER CONTACTS- BERYLLIUM COPPER PER ASTM-B-196
 SHIELD FERRULE- BRASS PER ASTM B453 OR QQ-B-626
 FRONT INSULATOR & SPACER INSULATOR- TFE RESIN PER AMS 3651
- FINISH:
 GOLD PLATED IN ACCORDANCE WITH SAE AS39029
 OVER NICKEL PLATE PER QQ-N-290 (.000050 MIN).
- CONTACTS MEET THE ENVELOPE DIMENSIONAL REQUIREMENTS OF M39029/91.

NOTES:

THE USE OF THIS DOCUMENT IS UNLIMITED. HOWEVER, DOCUMENTS REFERENCED HEREON MAY CONTAIN LIMITED RIGHTS DATA.

N/A
NEXT ASSEMBLY

PRO/ENGINEER INFORMATION
Pro/e Model Used:
21-033457-001.ASSEM
Drawing Name:
21-033457-001

UNLESS OTHERWISE SPECIFIED
SPECIFICATIONS
LINEAR DIMENSIONS ARE IN INCHES
TOLERANCES:
.XXXX = ±.0005 ANGLES= ±2°
.XXX = ±.010
.XX = ±.03
.X = ±.1
DIM. & TOL. PER ASME Y14.5M;
DRM PER MIL-DTL-31000;
OTHER Amphenol Stds. PER 9-3800
LEGENDS:
=FLAG NOTE CALL OUT
REFERENCE ONLY

SPECIFICATIONS
MATERIAL SPEC.
N/A
PROCESS SPEC.
N/A

POS	QTY	PART NUMBER	DESCRIPTION	NOTE
7	1	L-2119-BX	INSTALLATION INSTRUCTIONS	4
6	1	21-033321-030	PIGGYBACK GROMMET SEAL	4
5	1	21-033384-106	SHIELD FERRULE	
4	1	21-033382-005 OR 21-033382-025	SPACER INSULATOR	
3	1	21-033385-044	OUTER CONTACT	
2	1	21-033388-033	FRONT INSULATOR	
1	2	21-033451-002	INNER CONTACT	

APPROVALS	DATE
PREPARED BY D. PHILLIPS	
ENGINEER IN CHARGE L. RATCHFORD	17-Feb-09
DESIGN MANAGER H. JOHNSON	
DESIGN ACTIVITY GROUP MIL-AERO DEVELOP	

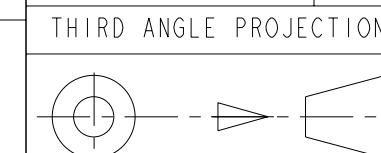

PARTS LIST

AMPHENOL CORPORATION
 40-60 DELAWARE AVENUE
 SIDNEY, N.Y. 13858

**CONTACT, SOCKET,
 DIFFERENTIAL TWINAX,
 TYPE M38999 I & III**

SIZE C	CAGE CODE 77820	DOCUMENT NO. 21-033457-001	REV. D
SCALE: 8.0		REF. 21-33388-31	SHEET 1 OF 1

21-033457-001

SHEET 1 OF 1

REV. D

C

B

A

FORMAT: C-U-E-I

DOCUMENT NO. 21-033457-001

SHEET 1 OF 1

REV. D

RELEASE STATE Released

SHEET 1 OF 1

21-033457-001