

REV. A	SHEET 1 OF 1	DOCUMENT NO. 21-033466-041
REVISIONS		
LTR	DESCRIPTION	DATE
A	INITIAL RELEASE	-

21-033466-041

SHEET 1 OF 1

REV. A

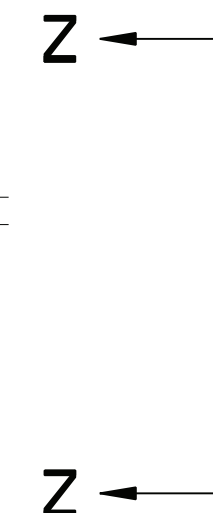
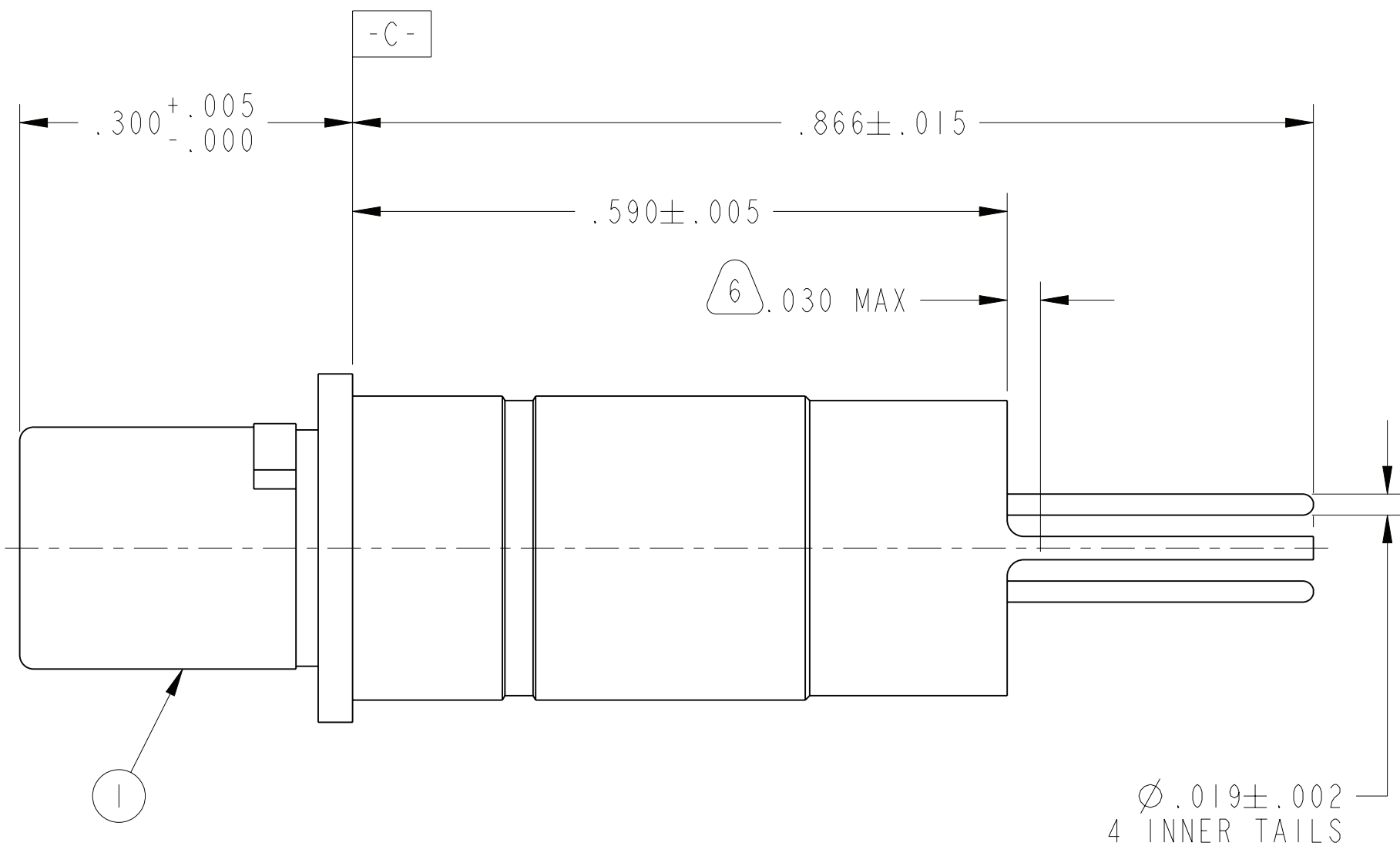
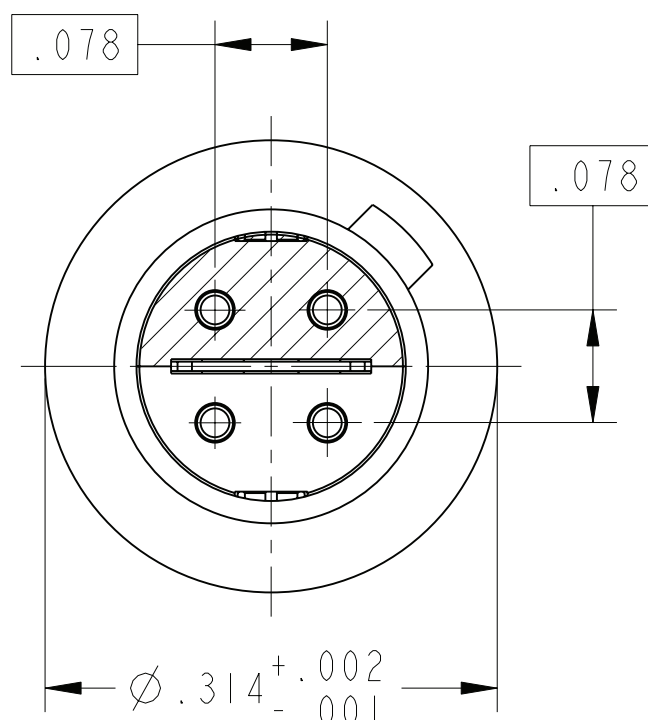

- 8. DIFFERENTIAL PAIRS:  
PAIR #1: P1-P4 (T1-T4)  
PAIR #2: P2-P3 (T2-T3)
- 7. INTERNAL ELECTRICAL CONNECTIONS:  
P1-T1, P2-T2, P3-T3, P4-T4
- 6. EPOXY MAY BE PRESENT ON CONTACT TAILS IN INDICATED AREA.
- 5. ALL DIMENSIONS ARE AFTER PLATING
- 4. MATES WITH M38999 QUADRAX 10G DESIGN SOCKETS 21-033471-( ) & OTHERS.
- 3. MATERIALS:  
OUTER & INNER CONTACTS- BERYLLIUM COPPER PER ASTM-B-196  
INSULATORS & RETAINER- POLYETHERIMIDE
- 2. FINISH:  
GOLD PLATED PER ASTM B488, TYPE II, CODE C, CLASS 1.27 (.000050 MIN)  
OVER NICKEL PLATE PER AMS-QQ-N-290 (.000050 MIN).
- 1. CONTACTS MEET THE ENVELOPE DIMENSIONAL REQUIREMENTS OF M39029/90.

NOTES:

THE USE OF THIS DOCUMENT IS UNLIMITED. HOWEVER, DOCUMENTS REFERENCED HEREON MAY CONTAIN LIMITED RIGHTS DATA.

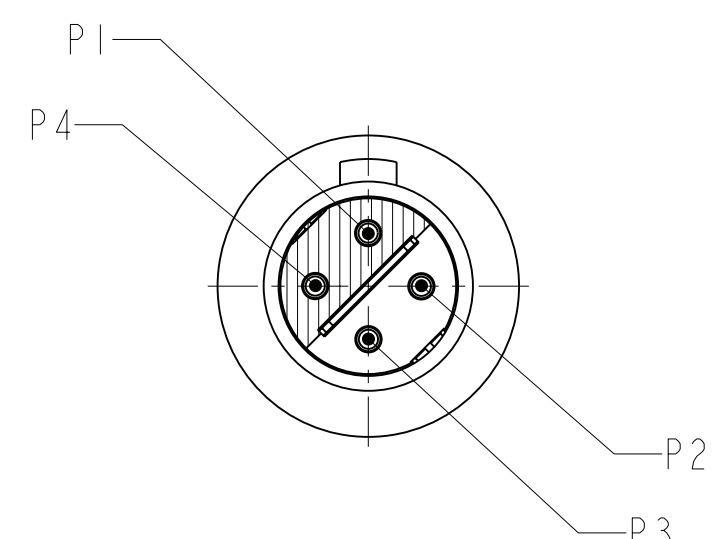
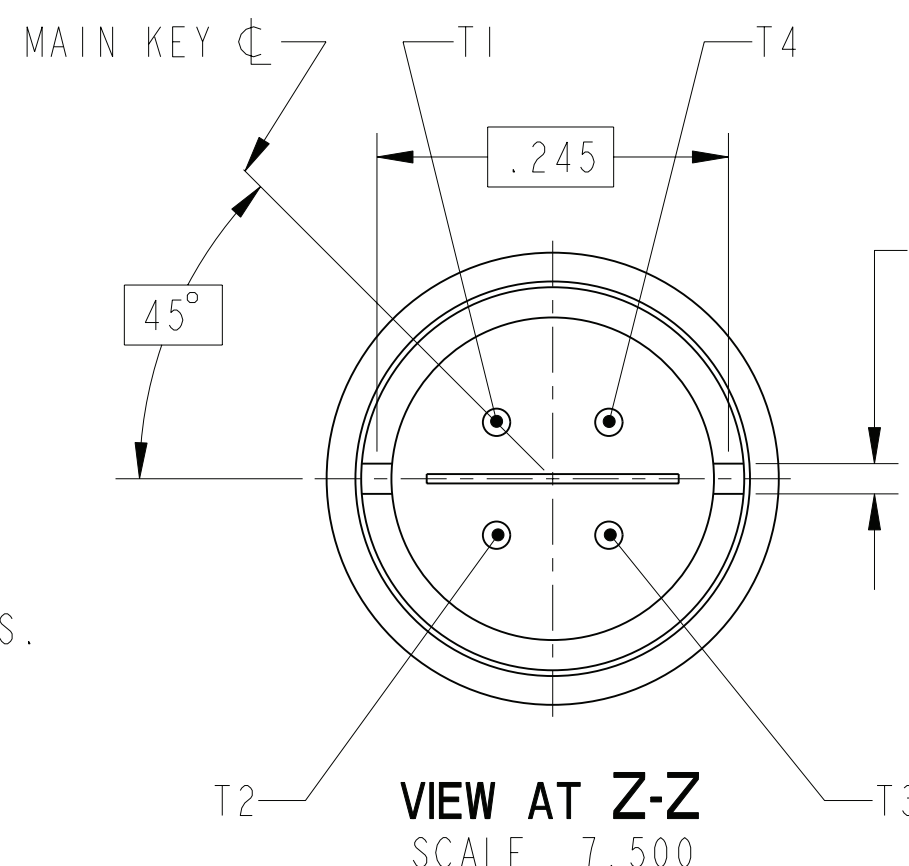

MATING FACE VIEW  
SCALE 5.000

VIEW AT Z-Z  
SCALE 7.500

RELEASED / Feb . 10 2012, 10:02:42 AM	DOCUMENT NO. 21-033466-041	SHEET 1 OF 1	REV. A
---------------------------------------	----------------------------	--------------	--------

N/A	PRO/ENGINEER INFORMATION Pro/e Model Used: 21-033466-041.ASSEM Drawing Name: 21-033466-041
-----	--

UNLESS OTHERWISE SPECIFIED	SPECIFICATIONS
LINEAR DIMENSIONS ARE IN INCHES TOLERANCES: .XXXX = ±.0005 ANGLES= ±2° .XXX = ±.010 .XX = ±.03 .X = ±.1	MATERIAL SPEC. N/A
DIM. & TOL. PER ASME Y14.5M; DRM PER MIL-DTL-31000; OTHER Amphenol Stds. PER 9-3800	PROCESS SPEC. SEE NOTE 5
LEGENDS: =FLAG NOTE CALL OUT REFERENCE ONLY	

POS	QTY	21-033466-041M	CONTACT ASSEMBLY	NOTE
PARTS LIST				
AMPHENOL CORPORATION 40-60 DELAWARE AVENUE SIDNEY, N.Y. 13858				
CONTACT, PIN, QUADRAX, SPLIT-PAIR ELECTRICAL CONNECTOR, TYPE D38999 I & III, PCB				
SIZE C	CAGE CODE 77820	DOCUMENT NO. 21-033466-041	REV. A	
SCALE: 7.5		REF. 21-033470-001	SHEET 1 OF 1	

FORMAT: C-U-E-I

21-033466-041 SHEET 1 OF 1 REV. A