

21-033470-031

SHEET 2 OF 2

REV. A

C

B

A

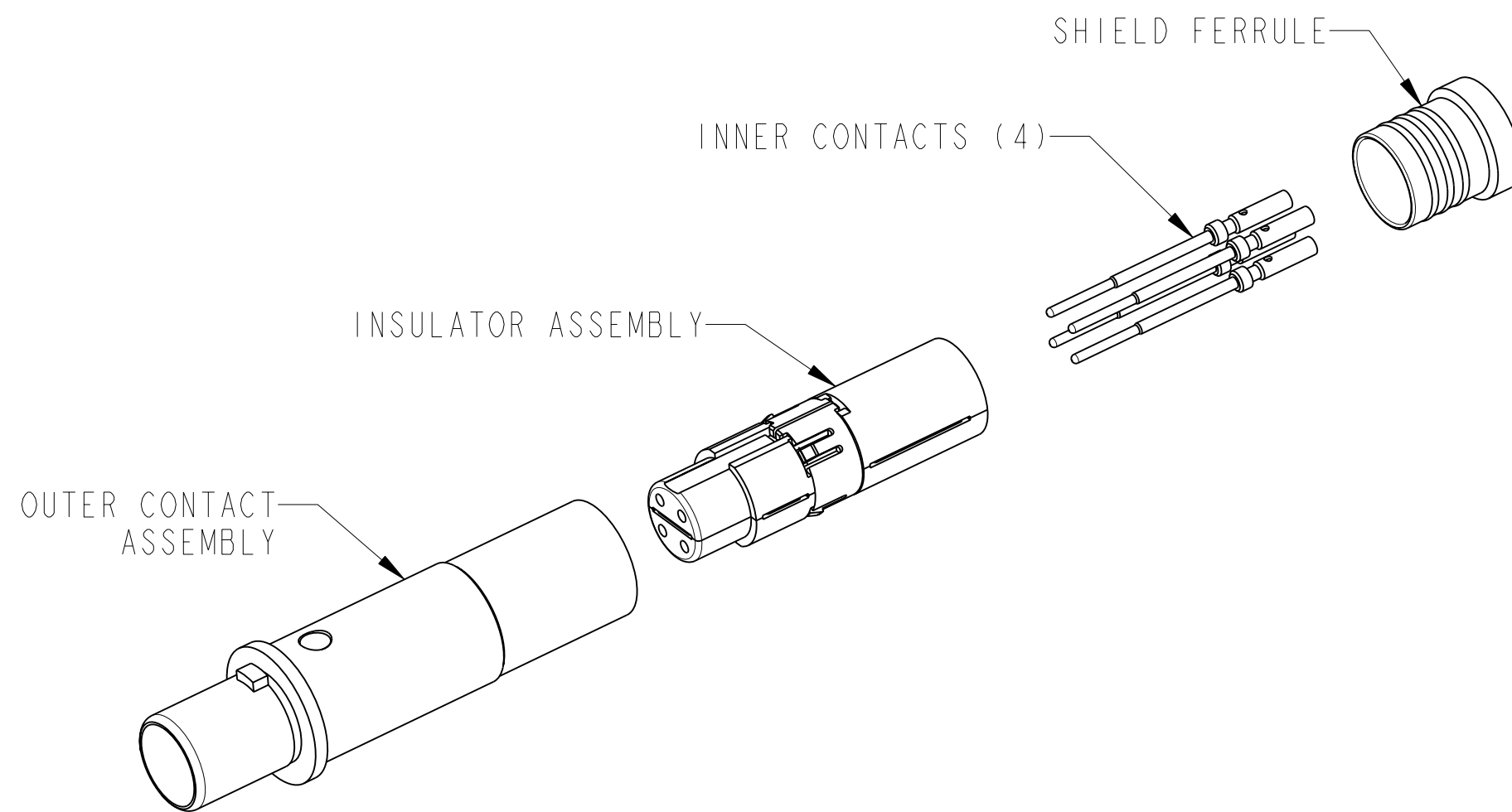

**EXPLODED COMPONENT VIEW
(PIGGYBACK SEAL NOT SHOWN)**
SCALE 3:1

7. MATES WITH D38999 QUADRAX SOCKETS 21-033471-031 & OTHERS.
6. CRIMPING TOOLS:
 OUTER CONTACT- M22520/5-01 TOOL, DANIELS Y1999 OR M22520/5-45 DIE SET (HEX CLOSURE A)
 INNER CONTACTS- M22520/2-01 TOOL, DANIELS K1777 POSITIONER
5. TERMINATES QUADRAX CABLE THERMAX 1536-224 (100 OHM) OR EQUIVALENT.
4. DRAWING ILLUSTRATES FINAL ASSEMBLY. CONTACT COMPONENTS ARE SHIPPED UNASSEMBLED. INSTALLATION INSTRUCTIONS & PIGGYBACK GROMMET SEAL (NOT ILLUSTRATED) ARE PACKAGED WITH EACH ASSEMBLY. PACKAGE PER PRODUCTION PROCESS SHEET.
3. MATERIALS:
 OUTER & INNER CONTACTS- BERYLLIUM COPPER PER ASTM-B-196
 SHIELD FERRULE- BRASS PER ASTM B453 OR QQ-B-626
 INSULATORS & RETAINER- POLYETHERIMIDE
2. FINISH:
 GOLD PLATED IN ACCORDANCE WITH SAE AS39029
 OVER NICKEL PLATE PER AMS-QQ-N-290 (.000050 MIN).
1. CONTACTS MEET THE ENVELOPE DIMENSIONAL REQUIREMENTS OF AS39029/90.

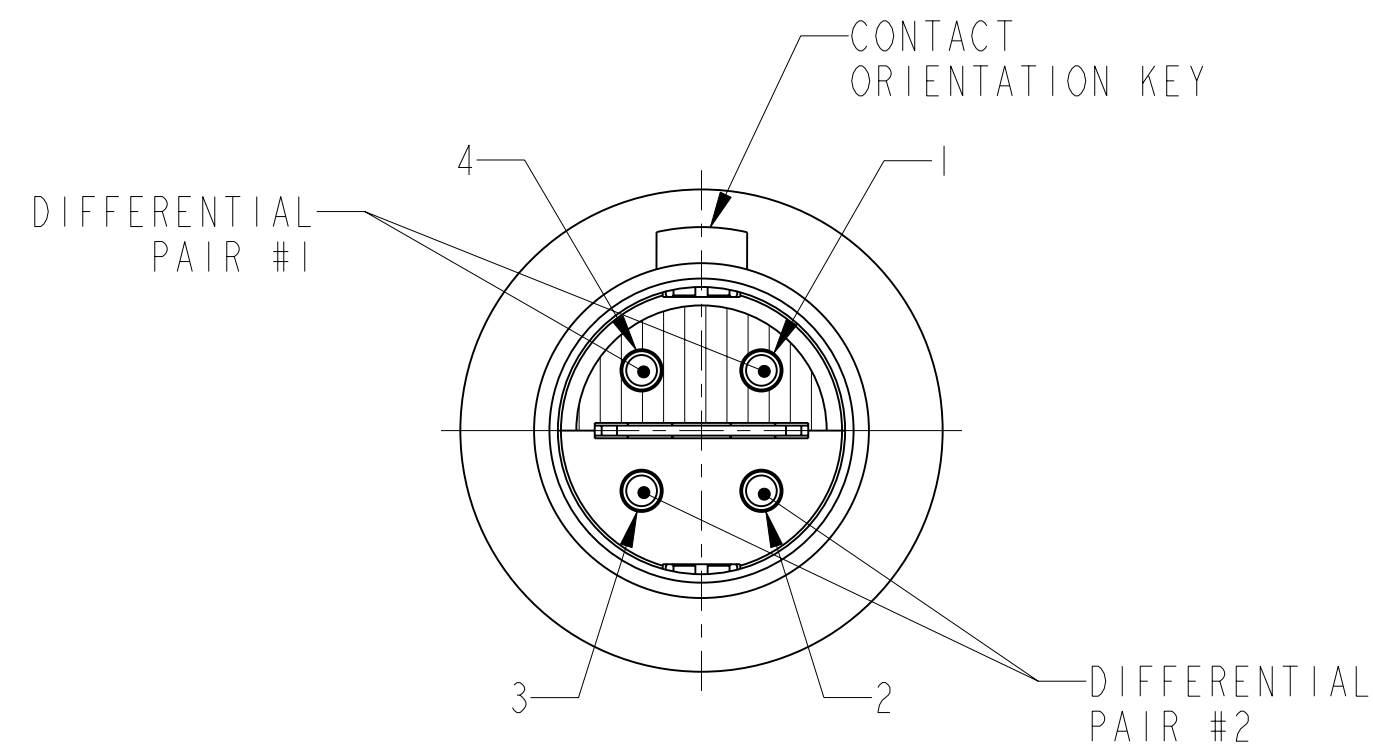

**MATING FACE VIEW
(RECOMMENDED CONTACT ID'S)**
SCALE 8:1

NOTES:

THE USE OF THIS DOCUMENT IS UNLIMITED. HOWEVER, DOCUMENTS REFERENCED HEREON MAY CONTAIN LIMITED RIGHTS DATA.

SIZE C	CAGE CODE 77820	DOCUMENT NO. 21-033470-031	REV. A
SCALE: 7.5:1		REF: 21-033470-001	SHEET 2 OF 2

21-033470-031
SHEET 2 OF 2
REV. A
Eng PDM Information For Reference Only
REVISION A
VERSION 3