

REV. B	SHEET 1 OF 1	DOCUMENT NO. 21-033611-003
REVISIONS		
LTR	DESCRIPTION	DATE
A	INITIAL RELEASE	
B	(CL 11) ECN 99069 ADDED "REF" TO BASIC DIM.	H.REEVE 2/15/06

21-033611-003

SHEET 1 OF 1

REV. B

C

B

A

D

C

0

B

Released

REV. B

SHEET 1 OF 1

21-033611-003

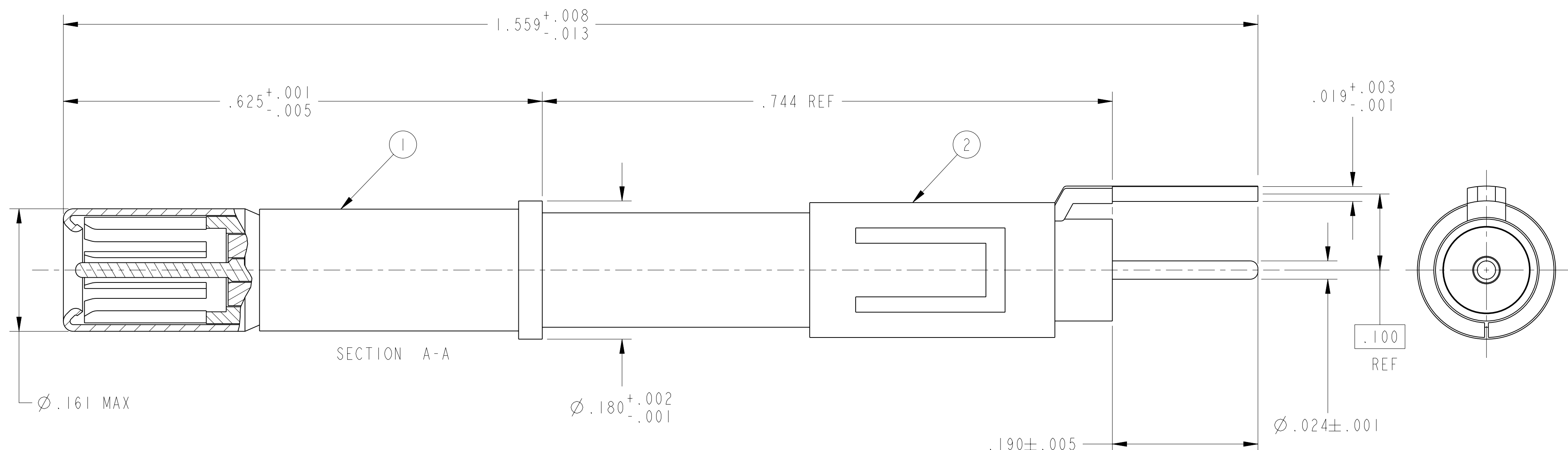
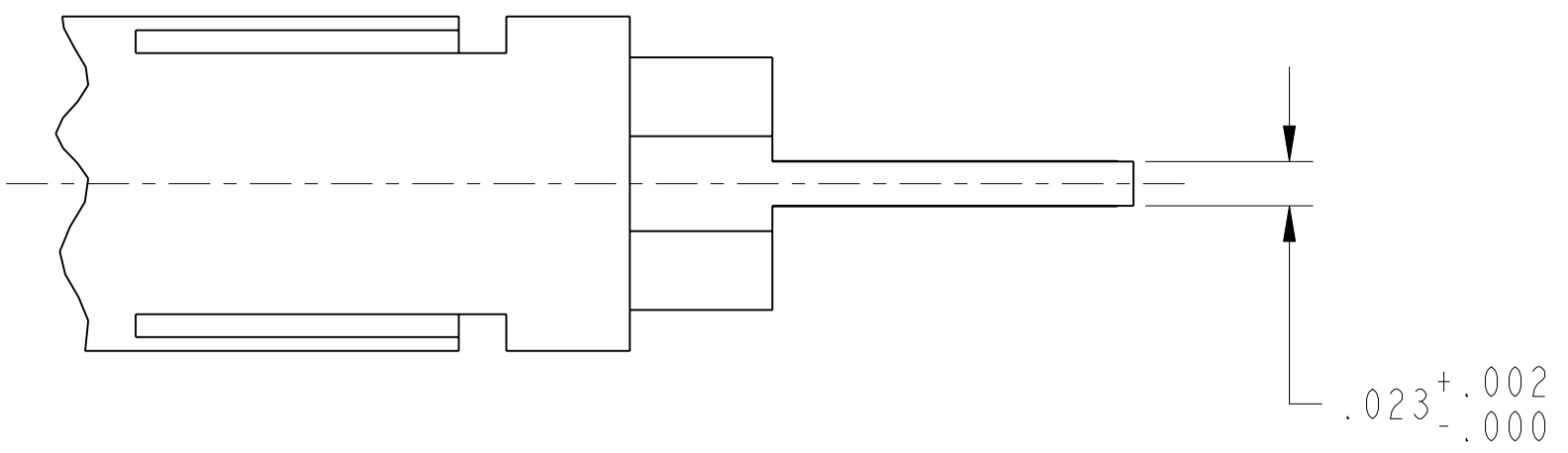

- 5. INDICATED AREA SHALL BE CAPABLE OF MEETING THE SOLDERABILITY REQUIREMENTS OF MIL-STD-202, METHOD 208.
- 4. ALL DIMENSIONS ARE AFTER PLATING.
- 3. MATERIALS: CONTACTS- BERYLLIUM COPPER PER ASTM B196, ALLOY C17300, TEMPER TD04
INSULATORS- PTFE PER ASTM 3651 OR EQUIVALENT
TAIL CLIP- BERYLLIUM COPPER PER ASTM B194, ALLOY C17200, TEMPER TD02
- 2. PACKAGE PER PRODUCTION PROCESS SHEET.
- 1. FINISH: GOLD PLATED PER MIL-G-45204 TYPE II, GRADE C, CLASS I OVER NICKEL PLATE PER QQ-N-290 (.000050 THICK MIN).

NOTES:

THE USE OF THIS DOCUMENT IS UNLIMITED. HOWEVER, DOCUMENTS REFERENCED HEREON MAY CONTAIN LIMITED RIGHTS DATA.

N/A NEXT ASSEMBLY

PRO/ENGINEER INFORMATION
 Pro/e Model Used:
 21-033611-003.ASSEM
 Drawing Name:
 21-033611-003

UNLESS OTHERWISE SPECIFIED
 LINEAR DIMENSIONS ARE IN INCHES
 TOLERANCES:
 .XXXX = ±.0005 ANGLES= ±2°
 .XXX = ±.010
 .XX = ±.03
 .X = ±.1
 DIM. & TOL. PER ASME Y14.5M;
 DRM PER MIL-DTL-31000;
 OTHER Amphenol Stds. PER 9-3800
 LEGENDS:
 =FLAG NOTE CALL OUT REFERENCE ONLY

SPECIFICATIONS
 MATERIAL SPEC. N/A
 PROCESS SPEC. N/A

POS	QTY	PART NUMBER	DESCRIPTION	NOTE
2	1	21-033691-002	REAR TAIL CLIP	
1	1	21-033611-03M	CONTACT ASSEMBLY	

APPROVALS	DATE
PREPARED BY H.REEVE	
ENGINEER IN CHARGE RATCHFORD	15-Feb-06
DESIGN MANAGER H. JOHNSON	
DESIGN ACTIVITY GROUP MIL-AERO DEVELOP	

AMPHENOL CORPORATION
 40-60 DELAWARE AVENUE
 SIDNEY, N.Y. 13858

CONTACT ASSEMBLY,
 SIZE 12 COAX,
 TYPE TV PCB

SIZE C	CAGE CODE 77820	DOCUMENT NO. 21-033611-003	REV. B
SCALE: 10:0		REF 21-33686-5	SHEET 1 OF 1