

REV. A	SHEET 1 OF 1	DOCUMENT NO. 21-033686-016
REVISIONS M		
LTR	DESCRIPTION	DATE
A	INITIAL RELEASE	

$\varnothing .019 \pm .001$
 2 PLACES
 $\varnothing .010 (M)$ $A(M)$

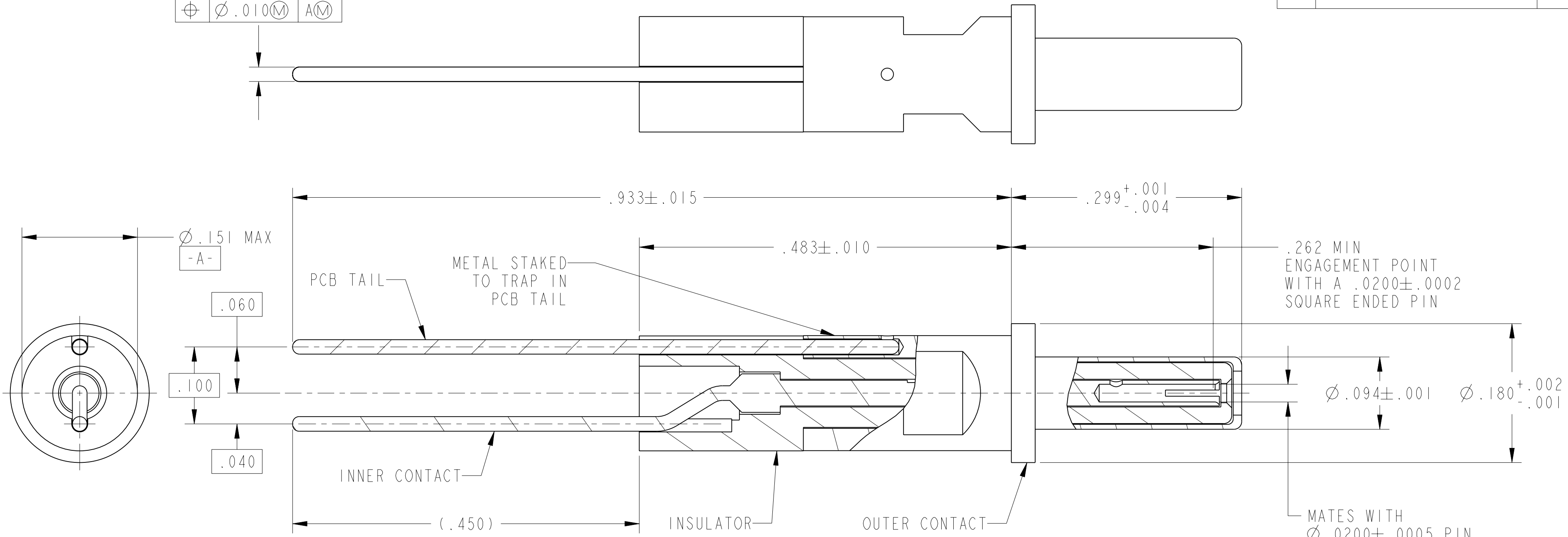

4. CONTACT ASSEMBLY SHALL BE SUBJECTED TO 500V AC DWV TESTING PRIOR TO SHIPPING.
3. PACKAGE PER PRODUCTION SHEET. HANDLE CAREFULLY TO AVOID DISTORTION OF PCB TAILS.
2. CLEANING OF PARTS IN CHLORINATED SOLVENTS IS NOT PERMISSIBLE.
1. MATES WITH COAXIAL SOCKET CONTACTS 21-33123-54(), 21-33121-54() AND OTHERS.

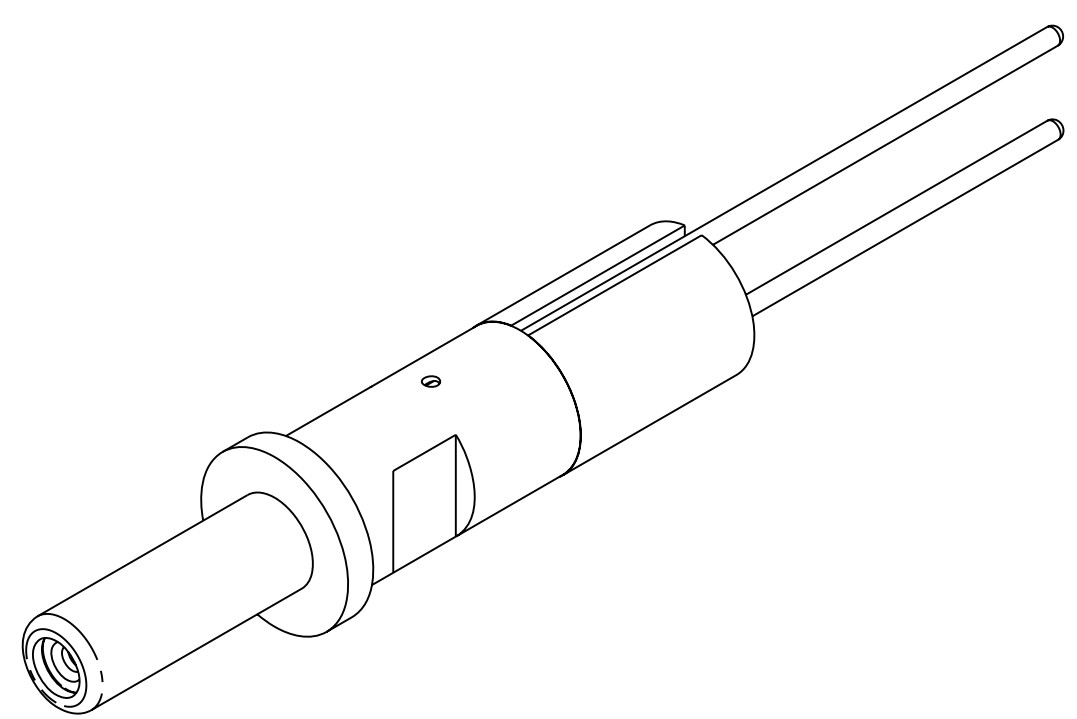

NOTES:

THE USE OF THIS DOCUMENT IS UNLIMITED. HOWEVER, DOCUMENTS REFERENCED HEREON MAY CONTAIN LIMITED RIGHTS DATA.

RELEASED / Apr . 16 2015, 1:29:12 PM

DOCUMENT NO. 21-033686-016 SHEET 1 OF 1 REV. A

10-646401-061() NEXT ASSEMBLY

PRO/ENGINEER INFORMATION
 Pro/e Model Used:
 21-033686-016.ASSEM
 Drawing Name:
 21-033686-016

UNLESS OTHERWISE SPECIFIED	SPECIFICATIONS	POS	QTY	PART NUMBER	DESCRIPTION	NOTE
LINEAR DIMENSIONS ARE IN INCHES TOLERANCES: .XXXX = ±.0005 ANGLES= ±2° .XXX = ±.010 .XX = ±.03 .X = ±.1 DIM. & TOL. PER ASME Y14.5M; DRM PER MIL-DTL-31000; OTHER Amphenol Stds. PER 9-3800 LEGENDS: =FLAG NOTE CALL OUT REFERENCE ONLY	MATERIAL SPEC.	APPROVALS		PARTS LIST		
	N/A	PREPARED BY J. CARNEVALE	DATE 10-Apr-15	AMPHENOL CORPORATION 40-60 DELAWARE AVENUE SIDNEY, N.Y. 13858		
PROCESS SPEC.	N/A	ENGINEER IN CHARGE D. PHILLIPS	DESIGN MANAGER E. HICKEY	CONTACT, PIN, COAXIAL, PCB ELECTRICAL CONNECTOR, TYPE M38999, SIZE 12		
		DESIGN ACTIVITY GROUP CI	THIRD ANGLE PROJECTION	SIZE C	CAGE CODE 77820	DOCUMENT NO. 21-033686-016
				SCALE: 10:0	REF. 21-033686-021	SHEET 1 OF 1

DOCUMENT NO. 21-033686-016 SHEET 1 OF 1 REV. A

DOCUMENT NO. 21-033686-016 SHEET 1 OF 1 REV. A