

REV. A		SHEET 1 OF 1		DOCUMENT NO. 21-033828-041	
REVISIONS					
LTR	DESCRIPTION			DATE	
A	INITIAL RELEASE			-	

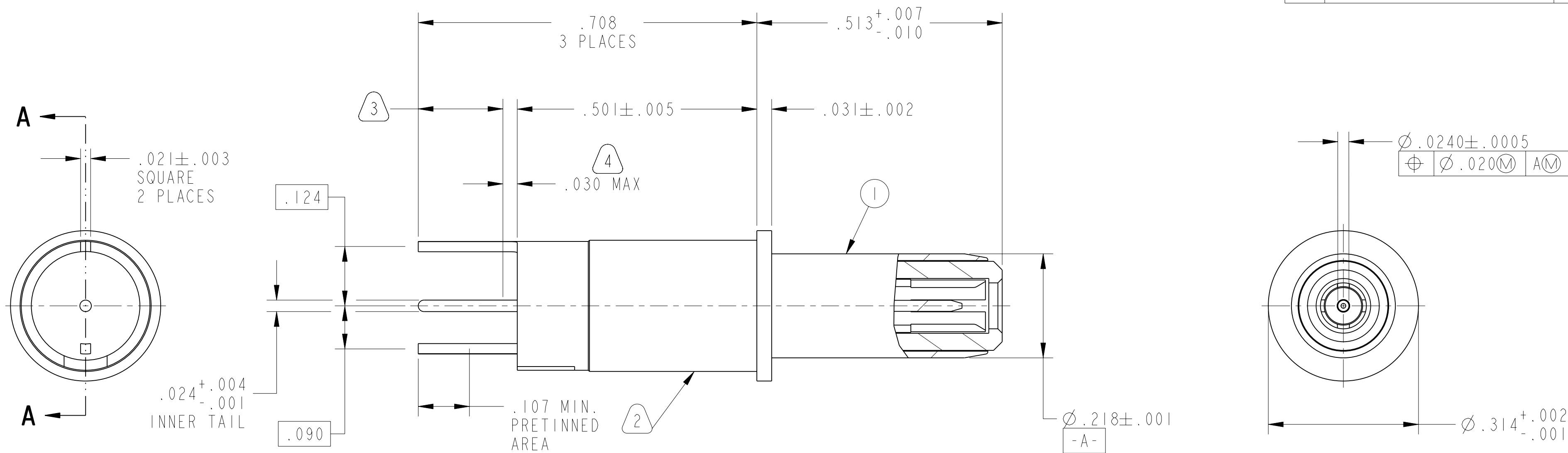

PARTIAL SECTION A-A

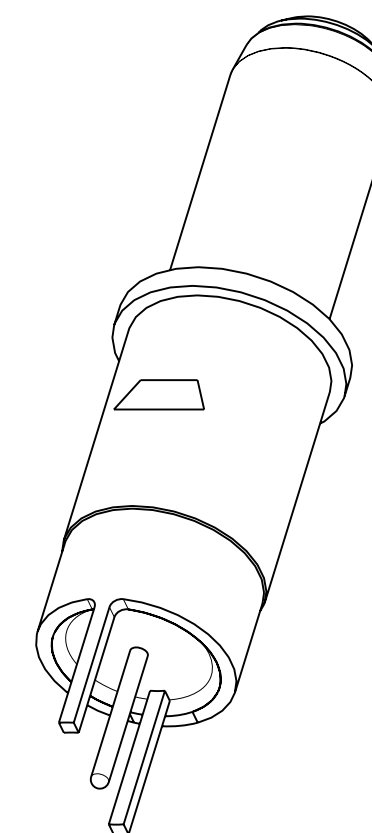

SCALE 4.000

1. PACKAGE PER PRODUCTION PROCESS SHEET.
2. BLACK INK STAMPED TRADEMARK MAY BE ON INDICATED SURFACE.
3. INDICATED AREA SHALL BE CAPABLE OF MEETING THE SOLERABILITY REQUIREMENTS OF 9-8825 AFTER STEAM AGING.
4. EPOXY MAY BE PRESENT ON CONTACT TAILS IN INDICATED AREA.
5. ALL DIMENSION ARE AFTER PLATING AND PRETINNING.

NOTES:

THE USE OF THIS DOCUMENT IS UNLIMITED. HOWEVER, DOCUMENTS REFERENCED HEREON MAY CONTAIN LIMITED RIGHTS DATA.

10-628485-486X
NEXT ASSEMBLY

RELEASED / Nov . 20 2006, 04:36 PM

DOCUMENT NO. 21-033828-041 SHEET 1 OF 1 REV. A

PRO/ENGINEER INFORMATION
Pro/e Model Used:
21-033828-041.ASSEM
Drawing Name:
21-033828-041

UNLESS OTHERWISE SPECIFIED	SPECIFICATIONS
LINEAR DIMENSIONS ARE IN INCHES TOLERANCES: .XXXX = ±.0005 ANGLES= ±2° .XXX = ±.010 .XX = ±.03 .X = ±.1	MATERIAL SPEC. N/A
DIM. & TOL. PER ASME Y14.5M; DRM PER MIL-DTL-31000; OTHER Amphenol Stds. PER 9-3800	PROCESS SPEC. N/A
LEGENDS: = FLAG NOTE CALL OUT REFERENCE ONLY	

I	I	21-033828-041M	TRIAx PIN CONTACT	
POS	QTY	PART NUMBER	DESCRIPTION	NOTE
PARTS LIST				
AMPHENOL CORPORATION 40-60 DELAWARE AVENUE SIDNEY, N.Y. 13858				
CONTACT, PIN, TRIAX SIZE 8, PCB, TYPE M38999 I & III				
APPROVALS	DATE			
PREPARED BY J. BORDEAU	30-Aug-06			
ENGINEER IN CHARGE L. RATCHFORD				
DESIGN MANAGER H. JOHNSON				
DESIGN ACTIVITY GROUP MIL-AERO				
THIRD ANGLE PROJECTION				
SIZE C	CAGE CODE 77820	DOCUMENT NO. 21-033828-041	REV. A	
SCALE: 6.0	REF. 21-33828-21	SHEET 1 OF 1		

DOCUMENT NO. 21-033828-041
 SHEET 1 OF 1
 REV. A
 RELEASE STATE Released
 REVISION A
 VERSION 4