

REV. A	SHEET 1 OF 1	DOCUMENT NO. 21-033909-101
REVISIONS		
LTR	DESCRIPTION	DATE
A	INITIAL RELEASE	

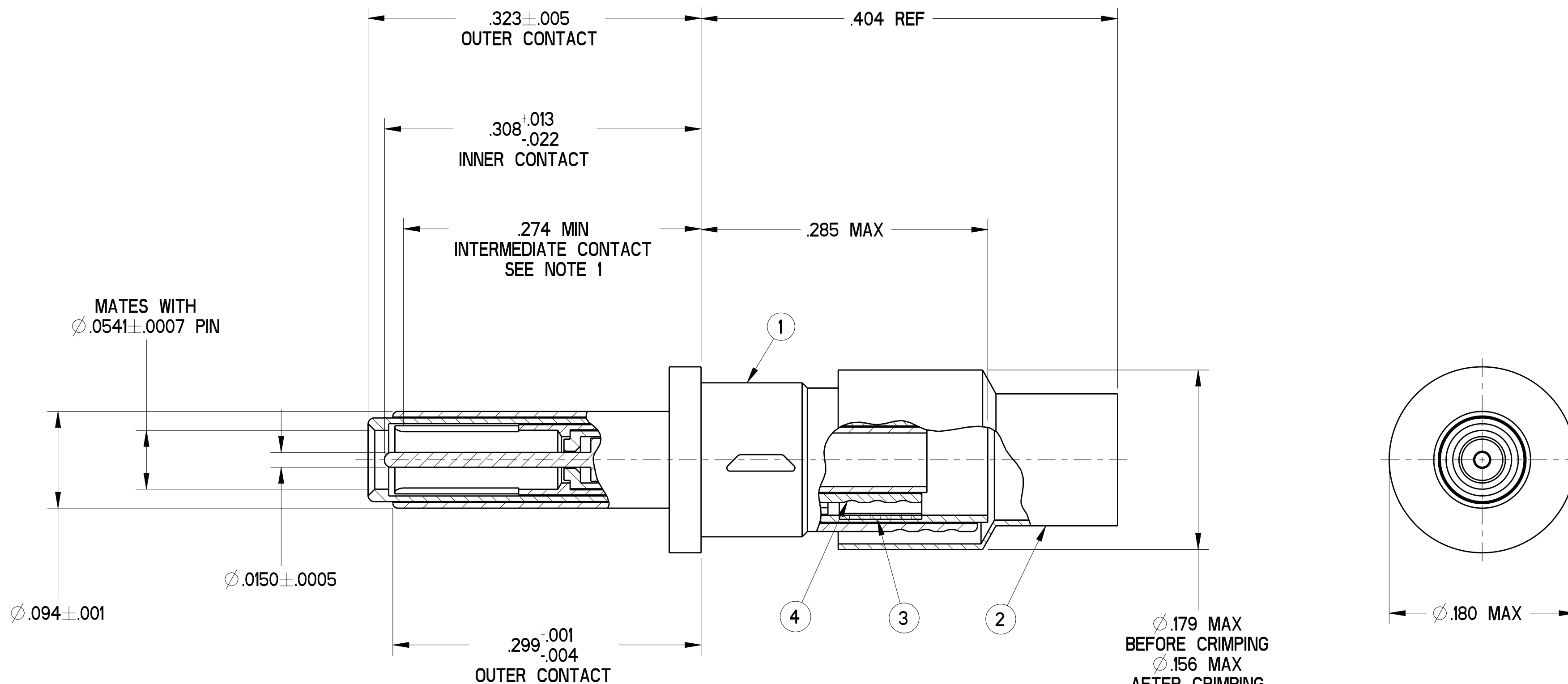

5. MATES WITH TWINAX & TRIAX SOCKET CONTACTS 21-33908-XX (JN1104*75T INTERFACE).
4. TERMINATES TWINAX CABLE VG95218T023D002 OR EQUIVALENT.
3. INDICATED COMPONENT IS NOT ILLUSTRATED. COMPLETE INSTALLATION INSTRUCTIONS PACKAGED WITH EACH ASSEMBLY. PACKAGE PER PRODUCTION PROCESS SHEET.
2. PROCESS SPEC:
TEST 9-5272-36
1. INDICATED DIMENSION IS FROM THE REAR OF THE OUTER CONTACT SHOULDER TO THE POINT AT WHICH A Ø.0541±.0002 SQUARE ENDED PIN ENGAGES THE INTERMEDIATE SOCKET CONTACT SPRING.

NOTES:

THE USE OF THIS DOCUMENT IS UNLIMITED. HOWEVER, DOCUMENTS REFERENCED HEREON MAY CONTAIN LIMITED RIGHTS DATA.

N/A

NEXT ASSEMBLY

PRO/ENGINEER INFORMATION

Pro/e Model Used:
21-033909-101.ASSEM
Drawing Name:
21-033909-101

UNLESS OTHERWISE SPECIFIED

LINEAR DIMENSIONS ARE IN INCHES
TOLERANCES:
.XXXX = ±.0005 ANGLES= ±2°
.XXX = ±.010
.XX = ±.03
.X = ±.1

DIM. & TOL. PER ASME Y14.5M;
DRM PER MIL-DTL-31000;
OTHER Amphenol Stds. PER 9-3800
LEGENDS:
=FLAG NOTE CALL OUT REFERENCE ONLY

SPECIFICATIONS

MATERIAL SPEC.
N/A

PROCESS SPEC.

SEE NOTE 2

POS	QTY	PART NUMBER	DESCRIPTION	NOTE
5	1	L-2092-AD	INSTALLATION INSTRUCTIONS	3
4	1	21-033628-091	INNER CONTACT ASSEMBLY	
3	1	21-033628-051	FERRULE, INTERMEDIATE	
2	1	21-033765-005	FERRULE, OUTER	
1	1	21-033751-006	OUTER CONTACT ASSEMBLY	

PARTS LIST

AMPHENOL CORPORATION
40-60 DELAWARE AVENUE
SIDNEY, N.Y. 13858

CONTACT, PIN, TWINAX,
ELECTRICAL CONNECTOR,
TYPE JT-R, SIZE 12

APPROVALS	DATE
PREPARED BY DJS MITH	26-Jan-09
ENGINEER IN CHARGE LRATCHFORD	
DESIGN MANAGER HJOHNSON	
DESIGN ACTIVITY GROUP MIL AERO DEVELOP	
THIRD ANGLE PROJECTION	

SIZE C	CAGE CODE 77820	DOCUMENT NO. 21-033909-101	REV. A
SCALE: 12.0	REF. 21-33909-91	SHEET 1 OF 1	

RELEASED / Oct. 22 2009, 11:12:51 AM

DOCUMENT NO. 21-033909-101

SHEET 1 OF 1

REV. A