

REVISIONS			
LTR	DESCRIPTION	DATE	APPVD
A	INITIAL RELEASE NUM: 70097-343		

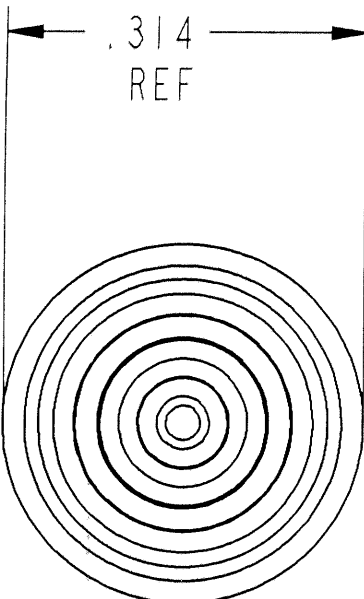
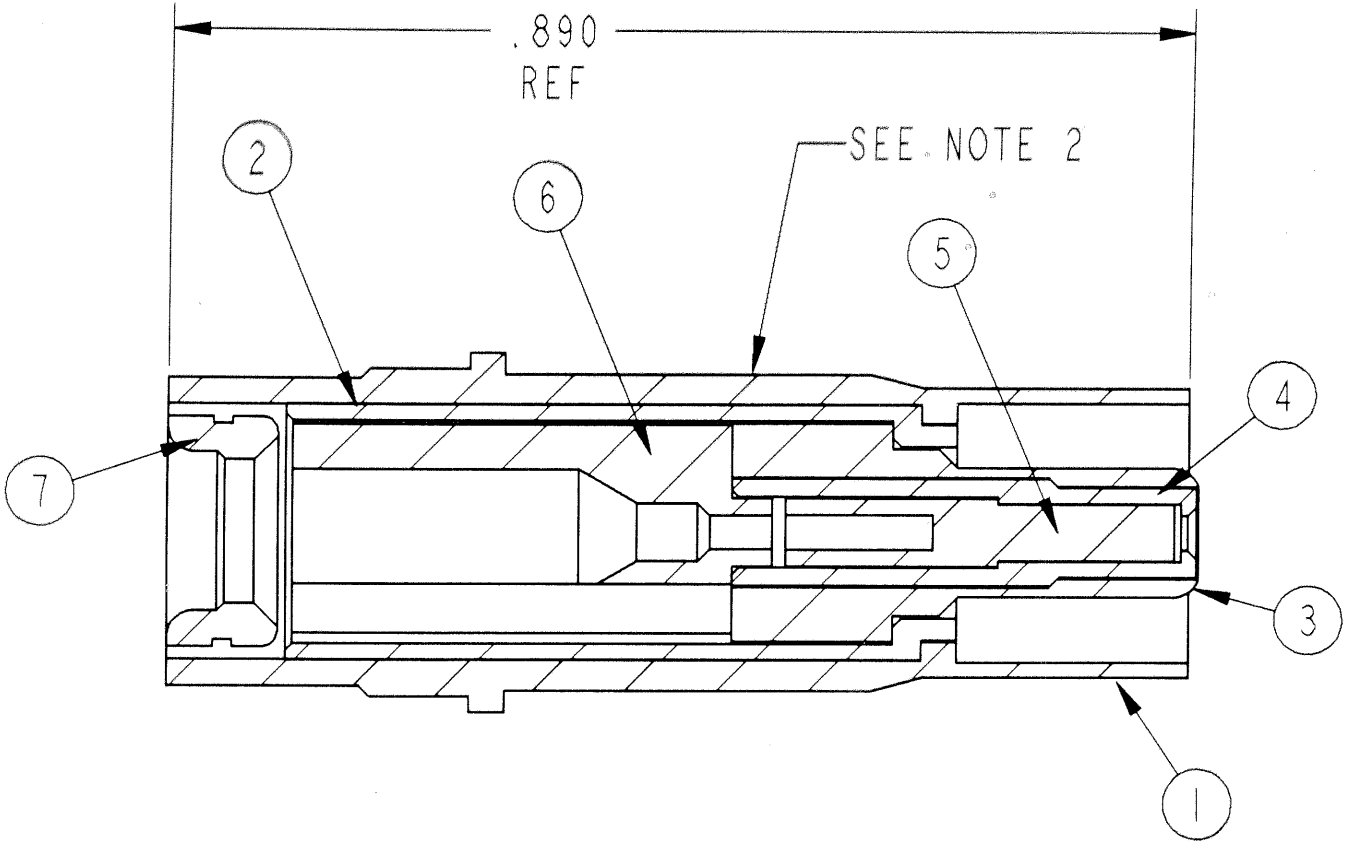

3. DRAWING ILLUSTRATES FINAL ASSEMBLY. COMPLETE INSTALLATION INSTRUCTIONS F/N 8 PACKED WITH EACH ASSEMBLY. PACKAGE PER PRODUCTION PROCESS SHEET.

2. BLACK INK STAMP TRADEMARK 9-6700 TYPE IV, PER 9-7530 OR 9-3856-5, IN APPROXIMATE POSITION SHOWN. DIRECTION OPTIONAL. TRADEMARK MAY BE SOLID AS SHOWN.

1. CONTACT DESIGNED FOR TERMINATION TO TWINAX CABLE MADE IN ACCORDANCE TO MI7/176-00002.

NOTES:

THE USE OF THIS DOCUMENT IS UNLIMITED. HOWEVER, DOCUMENTS REFERENCED HEREON MAY CONTAIN LIMITED RIGHTS DATA.

COMPANY ID: 9
 CODED/MS/CUST: N
 INTERNAL: N
 LOT NO: N
 DATE CODE: N
 SEE DRAW: N

10-593957-009
 N/A
 NEXT ASSEMBLY

UNLESS OTHERWISE SPECIFIED

LINEAR DIMENSIONS ARE IN INCHES
 TOLERANCES: .XXX = ±.0005
 .XXX = ±.010, XX = ±.03
 X = ±.1 ANGLES = ±2°
 AND DOD-D-1000
 THIRD ANGLE PROJECTION

MATERIAL SPEC.	N/A
PROCESS SPEC.	N/A
NEXT ASSEMBLY	

POS	QTY	PART NUMBER	DESCRIPTION	NOTE
8	1	PN-1005	INSTALLATION INSTRUCTIONS	
7	1	P-209546-34	FERRULE INNER	
6	1	10-568483	INSULATOR REAR	
5	1	P-209546-32	SOCKET CONTACT	
4	1	P-209546-31	INSULATOR INNER	
3	1	P-209546-30	PIN CONTACT	
2	1	10-568485	INSULATOR OUTER	
1	1	10-568484	OUTER BODY	

PARTS LIST

AMPHENOL CORPORATION
 BENDIX CONNECTOR OPERATIONS
 SIDNEY, N.Y.

TWINAX, SOCKET, CONTACT

APPROVALS	DATE	SIZE	FSCM NO.	DOCUMENT NO.	REV.
PREPARED SNYDER	01-Nov-96	B	77820	21-33922-15	A
CHECKED <i>[Signature]</i>	9/4/97	SCALE: 6.0 REF: P-209546-27 SHEET 1 OF 1			
MATERIAL <i>[Signature]</i>	9/10/97				
APPROVED <i>[Signature]</i>	9/4/97				
APPROVED <i>[Signature]</i>	9-8-97				
PRO/ENG MODEL INFORMATION 21-33922-15.ASSEM 21-33922-15					