

I = INTERMEDIATE CONTACT
 G = OUTER CONTACT
 C = CENTER CONTACT

REVISIONS				
ZONE	LTR	DESCRIPTION	DATE	APPROVED
	A	INITIAL RELEASE NUM: 70098-387		
	B	(CLII) MODIFIED NOTE 6 ECN:A6666	4/3/09	JHEATH

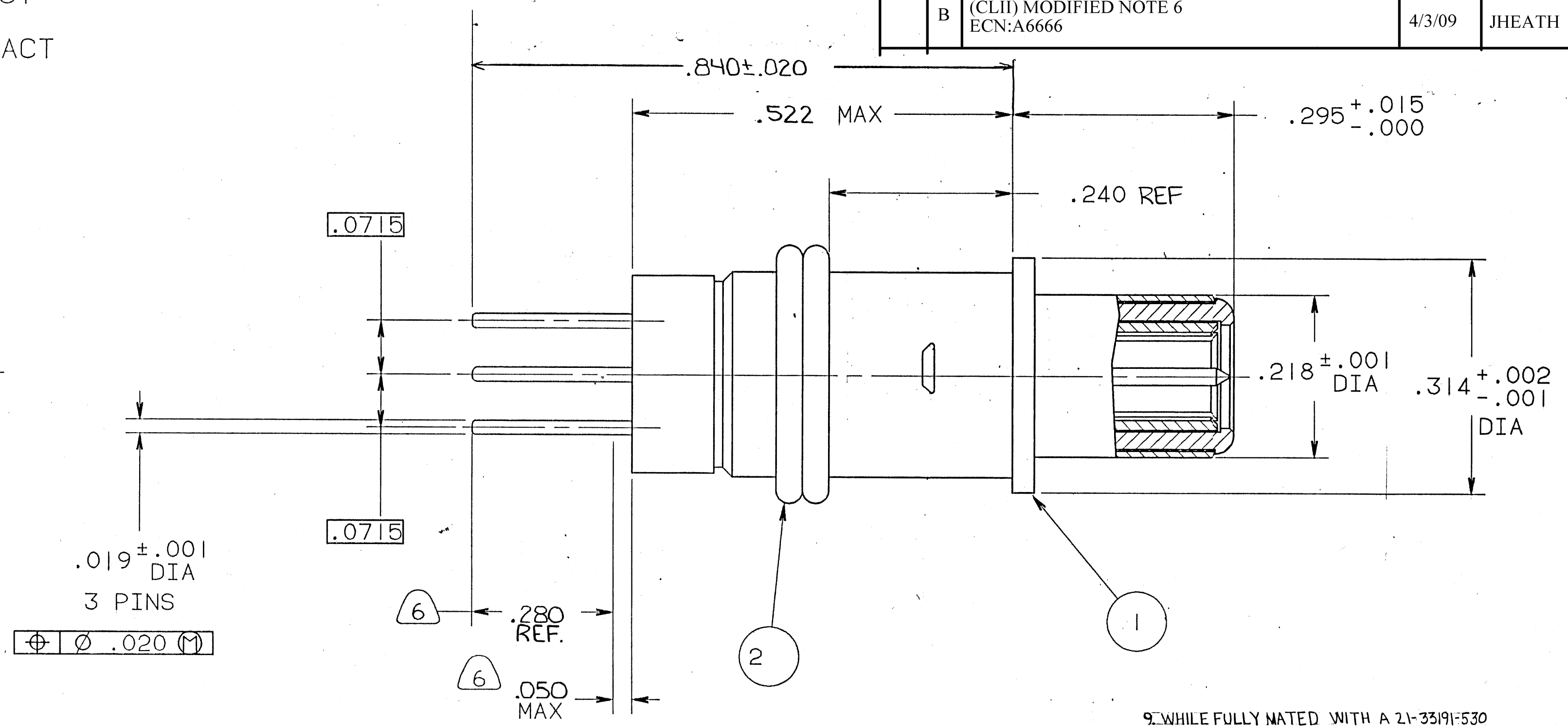
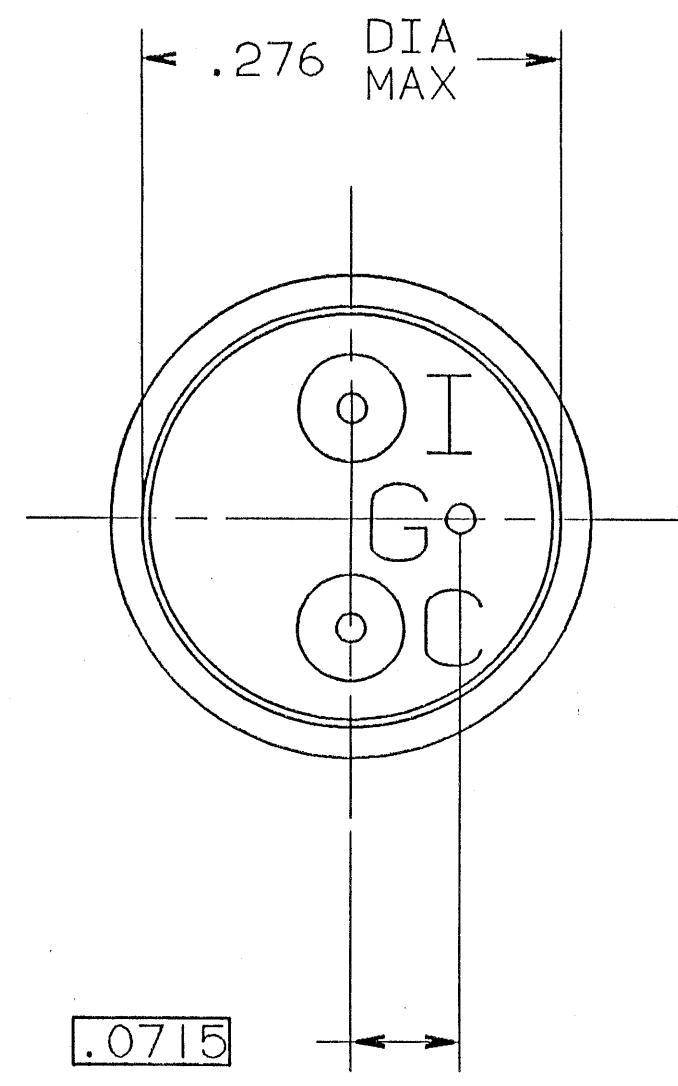

- PRETIN INDICATED AREA TO WITHIN .050 OF THE CONTACT BODY PER 9-7894 IN NITROGEN WAVE SOLDER POT. IF FLUX IS USED, REMOVE ONLY WITH ULTRASONIC CLEANING IN ISOPROPNOL (SEE NOTE 8).
- REMOVED
- CAUTION: HANDLE ASSEMBLY CAREFULLY TO PREVENT MISALIGNMENT OF PIN CONTACT TAILS.
- MATES WITH ANY SIZE 8 CONCENTRIC TWINAXIAL SOCKET CONTACT IN PART NUMBER SERIES 21-33191-().
- DRAWING ILLUSTRATES FINAL ASSEMBLY. PACKAGE PER PRODUCTION PROCESS SHEET (SEE NOTE 4).
- PROCESS SPEC:
TEST 9-5272-30,
ELECTRICAL TEST PER NOTES 7 & 9,
9-7894

- CLEANING OF PARTS IN CHLORINATED SOLVENTS IS NOT PERMISSIBLE.
- A TEST VOLTAGE OF 500 VOLTS AC RMS SHALL BE APPLIED BETWEEN THE CENTER CONTACT (C) AND THE INTERMEDIATE CONTACT (I) AND BETWEEN THE INTERMEDIATE CONTACT (I) AND THE OUTER CONTACT (G). THE VOLTAGE SHALL BE APPLIED FOR 5 SECONDS MINIMUM. THE LEAKAGE CURRENT SHALL NOT EXCEED 1 (ONE) MILLIAMPERE. THERE SHALL BE NO EVIDENCE OF BREAKDOWN OR FLASHOVER.

9. WHILE FULLY MATED WITH A 21-33191-530 TWINAX SOCKET CONTACT, A TEST VOLTAGE OF 15 VOLTS DC SHALL BE APPLIED BETWEEN THE PCB TAIL OF THE PIN CONTACT AND A POINT 3.500 ± .100 FROM THE REAR OF THE SOCKET CONTACT (SOCKET TERMINATED WITH MIL 176-00002 CABLE.) THE MAXIMUM VOLTAGE DROP SHALL BE 30 MILLIVOLTS WITH A TEST CURRENT OF 1 AMP. ALL THREE CONTACT TAILS MUST BE 100% CHECKED FOR THIS REQUIREMENT.

NOTES:
 THE USE OF THIS DOCUMENT IS UNLIMITED. HOWEVER, DOCUMENTS REFERENCED HEREON MAY CONTAIN LIMITED RIGHTS DATA.

MIL-C-38999 TYPE I & III CONN.
 NEXT ASSEMBLY

UNLESS OTHERWISE SPECIFIED LINEAR DIMENSIONS ARE IN INCHES.
 TOLERANCES: .XXX±.010,
 .XX ±.03, .X ±.1,
 ANGLES ±2°.
 OTHER STANDARDS PER 9-3800 AND DOD-D-1000.
 NOTE REF. =

FIND NO.	QTY REQD.	FSCM NO.	PART NUMBER	DESCRIPTION	NOTE REF.
2	2		21-33976-1	O-RING	
1	1		21-33968-55	CONTACT ASSEMBLY	

PARTS LIST			AMPHENOL CORPORATION CONNECTOR OPERATIONS SIDNEY, N.Y.		
SPECIFICATIONS	SIGNATURES	DATES			
MATERIAL SPEC. N/A	PREPARED <i>[Signature]</i>	10/5/98			
	CHECKED <i>[Signature]</i>	10/5/98			
	MATERIAL <i>[Signature]</i>	10/5/98			
	APPROVED <i>[Signature]</i>	10/5/98			
PROCESS SPEC. SEE NOTE 1	1ST PART NO.		SIZE C	FSCM NO. 77820	21-33967-55
			SCALE 10/1	WT.	REF 21-33876-1
					SHEET N/A