

REV. B	SHEETS 1 OF 2	DOCUMENT NO. CF-170900-LXX
REVISIONS M		
LTR	DESCRIPTION	DATE
A	INITIAL RELEASE	06/02/21
B	(CL 1) SEE ECN D3445	07/13/21

DOCUMENT NO. CF-170900-LXX

SHEET 1 OF 2

REV. B

C

B

A

FORMAT: C-U-E-1

PART NUMBER	L ±.015
CF-170900-L01	.333
CF-170900-L02	.270
CF-170900-L03	.158

TOSA CONTACT I/O CHART

PIN ID	FUNCTION
1	DISABLE
2	3.3VDC
3	GND
4	FAULT
5	INPUT-
6	INPUT+

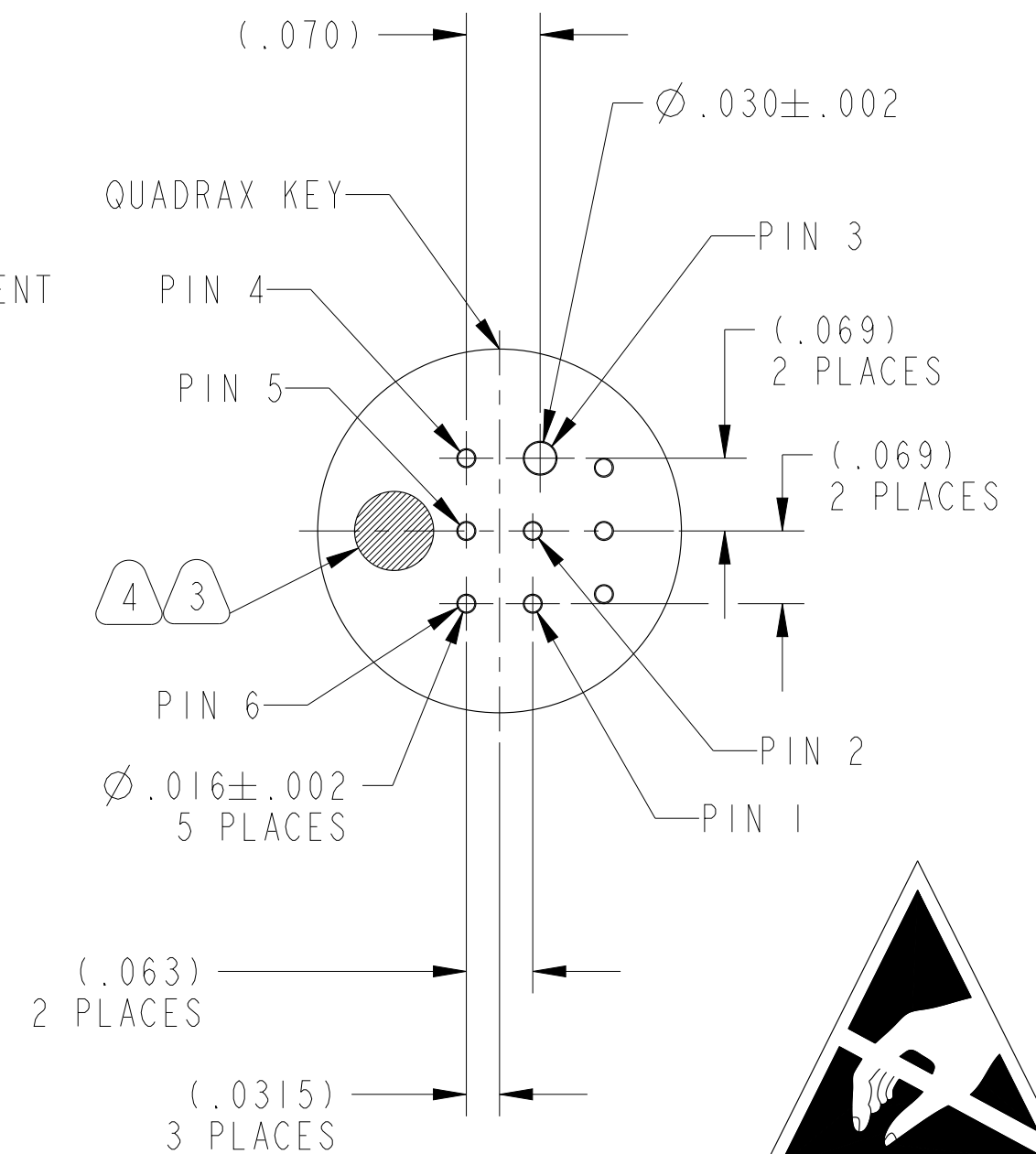
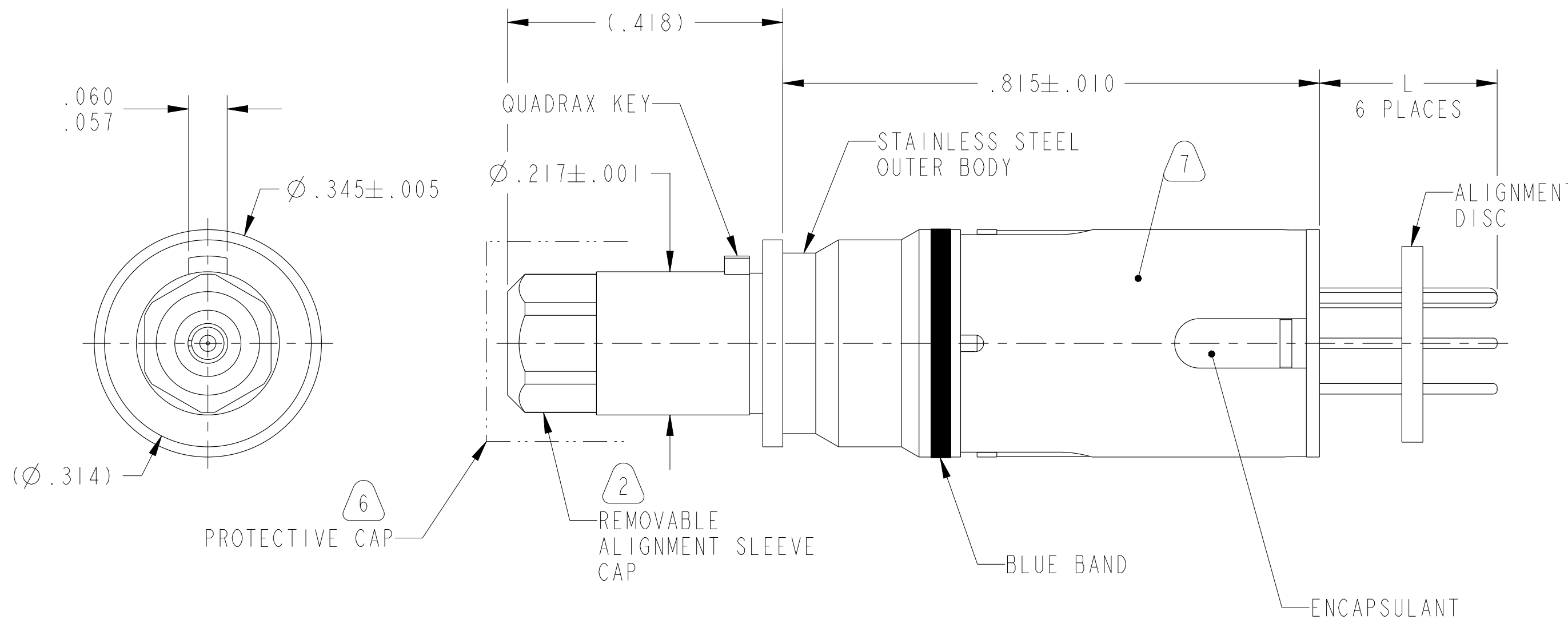

ATTENTION
OBSERVE PRECAUTIONS
FOR HANDLING
ELECTROSTATIC
SENSITIVE
DEVICES

SEE SHEET 2

NOTES:

THE USE OF THIS DOCUMENT IS UNLIMITED. HOWEVER, DOCUMENTS REFERENCED HEREON MAY CONTAIN LIMITED RIGHTS DATA.

CF-020012-053X
NEXT ASSEMBLY

PRO/ENGINEER INFORMATION
Pro/e Model Used:
CF-170900-LXX.ASSEM
Drawing Name:
CF-170900-LXX

UNLESS OTHERWISE SPECIFIED	SPECIFICATIONS	POS	QTY	PART NUMBER	DESCRIPTION	NOTE
LINEAR DIMENSIONS ARE IN INCHES TOLERANCES: .XXXX = ±.0005 ANGLES= ±2° .XXX = ±.010 .XX = ±.03 .X = ±.1	MATERIAL SPEC. NONE					
DIM. & TOL. PER ASME Y14.5M; DRM PER MIL-STD-31000; OTHER Amphenol Stds. PER 9-3800	PROCESS SPEC. SEE NOTE 12					
LEGENDS: = FLAG NOTE CALL OUT REFERENCE ONLY						
APPROVALS		DATE		PARTS LIST		
PREPARED BY W. LEE	ENGINEER IN CHARGE W. LEE	2-Jun-21		AMPHENOL CORPORATION 40-60 DELAWARE AVENUE SIDNEY, N.Y. 13858		
DESIGN MANAGER J. ROTHROCK	DESIGN ACTIVITY GROUP C1	THIRD ANGLE PROJECTION		FIBER QUAD ASSEMBLY SIZE 8 CONTACT, TOSA, LOW OUTGASSING 850nm MULTIMODE, 10G, VCSEL		
SIZE C	CAGE CODE 77820	DOCUMENT NO. CF-170900-LXX		REV. B	SCALE: 6.0 CF-170900-EXX SHEET 1 OF 2	

DOCUMENT NO. CF-170900-LXX

SHEET 1 OF 2

REV. B

VERSION 3

REVISION B

Eng. PDM Information For Reference Only

REV. B

SHEET 1 OF 2

DOCUMENT NO. CF-170900-LXX

CF-170900-LXX

SHEET 2 OF 2

REV. B

C

B

A

**INVISIBLE LASER RADIATION
DO NOT VIEW DIRECTLY WITH
OPTICAL INSTRUMENTS
760 - 1050nm
CLASS 1 LASER PRODUCT**

**LASER RADIATION
AVOID EXPOSURE TO BEAM
CLASS 1 PRODUCT**

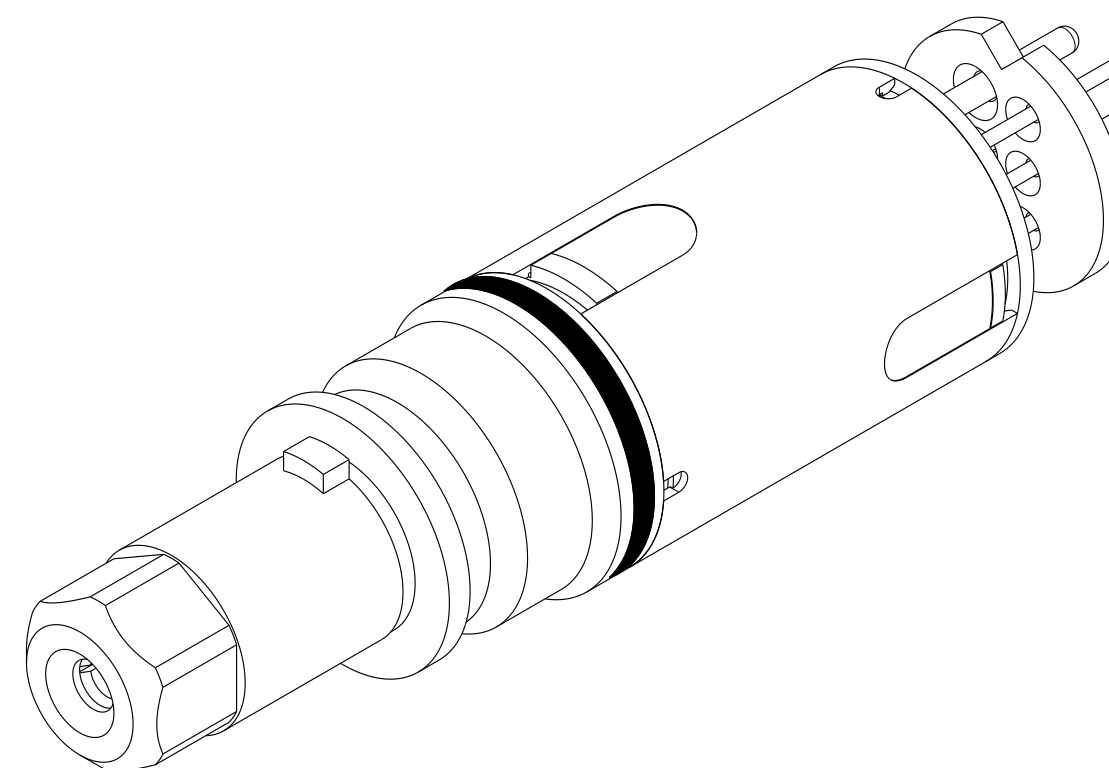

FRONT ISO VIEW
SCALE 5.000

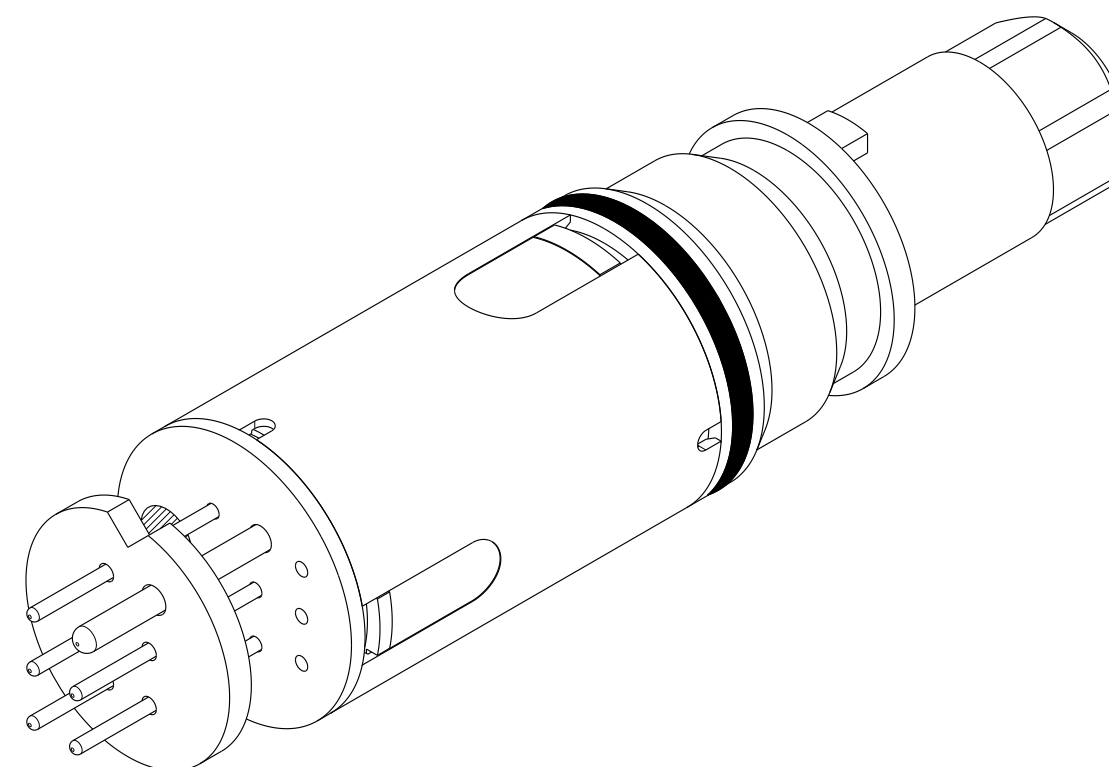

REAR ISO VIEW
SCALE 5.000

- 13. MATERIAL OUTGASSING SHALL NOT EXCEED 1% TML AND 0.1% CVMC PER ASTM E595.
- 12. PROCESS SPECS: 9-3856-14, 9-3895
- 11. FIBER LINES SHALL BE 850nm SIGNAL COMPATIBLE 50/125 GRADED INDEX MULTIMODE FIBER.
- 10. AVERAGE OPTICAL OUTPUT POWER: -5 dBm
- 9. OPERATING TEMPERATURE: -40°C TO 85°C
STORAGE TEMPERATURE: -40°C TO 85°C
- 8. ASSEMBLY CONTAINS ELECTROSTATIC DISCHARGE (ESD) SENSITIVE COMPONENTS. ASSEMBLY SHALL BE HANDLED, PACKAGED, AND SHIPPED TO MEET REQUIREMENTS OF ANSI/ESD-S-20.20 AND IPC-610.
- 7. STAMP "AMPHENOL", PART NUMBER, DATE CODE & LOT NO.(9-3895) ON INDICATED SURFACE WITH CONTRASTING COLOR PER 9-3856-14.
- 6. PROTECTIVE CAP SHALL BE INSTALLED PRIOR TO SHIPPING.
- 5. PACKAGE PER PRODUCTION PROCESS SHEET.
- 4. BLACK INK STAMP $\varnothing .075 \pm .025$ DOT PER 9-3856-14 APPROXIMATELY ON INDICATED LOCATION.
- 3. BLACK DOT DENOTES LOW OUTGASSING 10G 850nm MULTIMODE TOSA WITH VCSEL LIGHT SOURCE.
- 2. IF ALIGNMENT SLEEVE CAP IS REMOVED FOR CLEANING, TO RE-INSTALL TORQUE TO 22-25 IN-LB (352-400 IN-OZ).
- 1. CONTACT FITS IN STANDARD 38999 SERIES III QUADRAX CAVITIES.

NOTES:

THE USE OF THIS DOCUMENT IS UNLIMITED.
HOWEVER, DOCUMENTS REFERENCED HEREON
MAY CONTAIN LIMITED RIGHTS DATA.

FORMAT: C-0-E-1

DOCUMENT NO. CF-170900-LXX

SHEET 2 OF 2

REV. B

SIZE C	CAGE CODE 77820	DOCUMENT NO. CF-170900-LXX	REV. B
SCALE: 6.0		REF: CF-170900-EXX	SHEET 2 OF 2

VISION 3

REVISION B

Eng PDM Information For Reference Only

REV. B

SHEET 2 OF 2

DOCUMENT NO. CF-170900-LXX