

156-CHANNEL 50G/400G PAM-4 RUGGED ETHERNET SWITCHBOX



DESCRIPTION

Amphenol's Rugged 156-Channel 50G/400G PAM-4 Ethernet Switch Box is conduction cooled and configurable for system connectivity, speeds, port types, and interoperability with various high-speed media converters and connectors for system interfacing.

This switch box features 12 copper ports and 144 fiber optic ports, each capable of 1GBase-SX, 10GBase-SR, 40GBaseSR4, 25GBase-SR, and 100GBase-SR4 50GBase-SR + 400BGase-SR8. In Amphenol's state of the art communications testing center, the switch boxes are aggressively tested at line rates to RFC 2889 for switching and RFC 2544 for L2/L3 performance, latency, packet forwarding, and other key metrics.

The switch is manufactured using derivatives of Amphenol's MIL-DTL-38999 Series connectors. These connectors contain standard AS39029 qualified Size 22D contacts, Octonet contacts, and 48F MT Ferrule FiberOptic contact assemblies.

Amphenol's Octonet Contacts are a proven design used in a variety of Military Programs. The Octonet is a Size 8 contact which houses (4) differential pair contacts. It is a 100 Ohm impedance contact, capable of a data rate of 4 Gbps maximum per contact pair. The contact system has been tested and passed all the Qualification Requirements of an AS39029 contact. The MT ferrules are used for fiber optic Ethernet ports and the AS39029 style contacts are used for power inputs and management functions.



12-CHANNEL 10G COPPER RUGGED ETHERNET SWITCH

FEATURES & BENEFITS

- 144 fiber optic non-blocking switched Ethernet ports capable of 1GBase-SX, 10GBase-SR, 40GBase-SR4, 25GBase-SR, 100GBase-SR4 protocols, 50GBase-SR, and 400GBase-SR8.
- 12 channels of copper capable of 10GBase-T
- 28V MIL-STD-704A input module; VICOR MFM and DC/DC mil-spec power supply with hold-up capacitor and in-rush current limiting circuit.
- Built-in test functionality for power up, initiated, and continuous operation.
- Host management processor:
 - Multicast
 - Link Aggregation Control Protocol (LACP)
 - Protocol-Independent Multicast (PIM)
 - Internet Group Management Protocol (IGMP)
 - Simple Network Management Protocol (SNMP)
 - Capable of supporting thousands of virtual local area networks (VLAN) each with its own dynamic host configuration protocol (DHCP) server for various devices within the VLAN
 - Configurable cross VLAN multicast routing
 - Storm-prevention
 - IPV4 and IPV6 support
 - Spanning tree protocol
 - Temperature and current monitoring and thermal shutdown in the event of over temperature
 - SSH, NTP, PTP, TFTP, secure FTP support
 - Custom configuration files
 - Web server interaction
 - Other
- Link status on demand, port counter status, configurable port speed/routing, ARP list, drop report, ping, MTU configuration, LUA configuration
- Power connector, debug connector, maintenance connector – all D38999's
- Mil-Spec black painted chassis with cold plate external conduction cooling

ENVIRONMENTAL

- -55 C to 85 C operating depending on altitude – perfect for military aerospace environmentsConduction cooled for cold plate interface
- Shock, vibration, bench handling, EMI/EMC per 461E, 704F power, salt/fog/dust, fluids/rain, explosive atmosphere, humidity
- Plating & paint is configurable but currently Mil-Spec black paint with back cover chromated for grounding

SOFTWARE FEATURES

Stacking	Defining IP Addresses	Managing System Files
Stacking Ring Topology	Configuring IP Addressing	Downloading System Files
Stacking Chain Topology	Defining IP Addresses	Firmware Download
Stacking Members and Unit ID	Defining ARP	Configuration Download
Removing and Replacing Stacking Members	Defining Domain Name Servers	Uploading System Files
Exchanging Stacking Members	Defining DNS Servers	Upload Type
Switching the Stacking Master	Defining DNS Host Mapping	Software Image Upload
Configuring System Time	Defining the Forwarding Database	Configuration Upload
Configuring Daylight Savings Time	Defining Static Forwarding Database Entries	Copying Files
Configuring SNTP	Defining Dynamic Forwarding Database Entries	Restoring the Default Configuration File
Polling for Unicast Time Information	Configuring Spanning Tree	Configuring Quality of Service
Polling for Anycast Time Information	Defining Classic Spanning Tree	Quality of Service Overview
Broadcast Time Information	Defining STP on Interfaces	VPT Classification Information
Defining SNTP Settings	Defining Rapid Spanning Tree	CoS Services
Configuring Device Security	Defining Multiple Spanning Tree	Defining General QoS Settings
Configuring Management Security	Defining MSTP Instance Settings	Configuring QoS General Settings
Configuring Authentication Methods	Defining MSTP Interface Settings	Restoring Factory Default QoS Interface Settings
Defining Access Profiles	Configuring SNMP	Defining Queues
Defining Profile Rules	SNMP v1 and v2c	Defining Bandwidth Settings
Defining Authentication Profiles	SNMP v3	Mapping CoS Values to Queues
Mapping Authentication Methods	Configuring SNMP Security	Mapping DSCP Values to Queues
Defining RADIUS Settings	Defining SNMP Security	Defining CoS Basic Mode
Defining TACACS+ Authentication	Defining SNMP View	Defining Basic Mode Settings
Configuring Passwords	Defining SNMP Group Profiles	Rewriting Basic Mode DSCP Values
Defining Local Users	Defining SNMP Group Members	Defining CoS Advanced Mode
Defining Line Passwords	Defining SNMP Communities	Setting Policy Binding
Defining Enable Passwords	SNMP Communities Basic Table	Managing Device Diagnostics
Configuring Network Security	SNMP Communities Advanced Table	Configuring Port Mirroring
Network Security Overview	Configuring SNMP Notifications	Viewing Statistics
Port-Based Authentication	Defining SNMP Notification Global Parameters	Viewing Interface Statistics
Advanced Port-Based Authentication	Defining SNMP Notification Filters	Viewing Interface Statistics
Defining Port Authentication Properties	Defining SNMP Notification Recipients	Receive Statistics
Defining Port Authentication	SNMPv1,2c Notification Recipients	Transmit Statistics
Configuring Multiple Hosts	SNMPv3 Notification Recipients	Viewing Etherlike Statistics
Defining Authentication Hosts	Configuring Multicast Forwarding	Managing RMON Statistics
Viewing EAP Statistics	Multicast Forwarding	Viewing RMON Statistics
Defining Access Control Lists	Typical Multicast Setup	Configuring RMON History
Defining IP Based Access Control Lists	Multicast Operation	Defining RMON History Control
Defining MAC Based Access Control Lists	Multicast Registration	Viewing the RMON History Table
Binding Device Security ACLs	Multicast Address Properties	Configuring RMON Events
Managing Port Security	Defining Multicast Properties	Defining RMON Events Control
Enabling Storm Control	Adding MAC Group Address	Viewing the RMON Events Logs
Configuring System Logs	Adding IP Multicast Groups	Defining RMON Alarms
Defining General Log Properties	Configuring IGMP Snooping	
Viewing Memory Logs	Configuring MLD Snooping	
Viewing Flash Logs	Viewing IGMP/MLD IP Multicast Groups	
Configuring Interfaces	Defining Multicast Router Ports	
Configuring Ports	Defining Forward All Multicast	
Aggregating Ports	Defining Unregistered Multicast Settings	
Configuring LACP		
Configuring VLANs		
Defining VLAN Properties		
Defining VLAN Membership		
Defining VLAN Interface Settings		
Configuring GARP		
Defining GARP		
Defining GVRP		
Viewing GVRP Statistics		

12-CHANNEL 10G COPPER RUGGED ETHERNET SWITCH BLOCK DIAGRAM

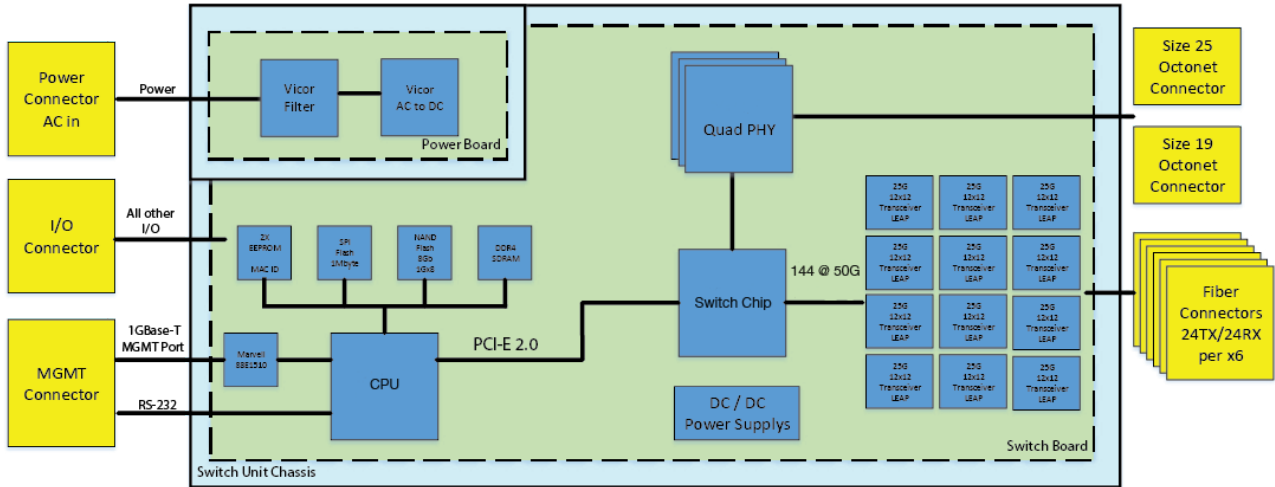

Notice: Specifications are subject to change without notice. Contact your nearest Amphenol Corporation Sales Office for the latest specifications. All statements, information and data given herein are believed to be accurate and reliable but are presented without guarantee, warranty, or responsibility of any kind, expressed or implied. Statements or suggestions concerning possible use of our products are made without representation or warranty that any such use is free of patent infringement and are not recommendations to infringe any patent. The user should assume that all safety measures are indicated or that other measures may not be required. Specifications are typical and may not apply to all connectors.

AMPHENOL is a registered trademark of Amphenol Corporation.
PRELIMINARY

©2023 Amphenol Corporation REV:



40-60 Delaware Avenue
Sidney, NY 13838
amphenol-aerospace.com | amphenolmao.com

Jared Sibrava | +1 (607) 643-1845 | jsibrava@amphenol-aao.com
amphenol-aerospace.com