

ETV38999

LOW COST RUGGEDIZED INTERCONNECT FOR THE NEXT GENERATION AIRCRAFT

PDS - 318-1



ETV38999 PROVIDES A SOLUTION THAT MEETS YOUR BUDGET AND PERFORMANCE GOALS

ETV38999 is a high-performance circular connector product range developed for next generation aeromotive applications where performance must be met with affordability.

This aeromotive 38999 is ideal for the Urban Air Mobility market where high performance mil-spec style products are needed at a cost effective price. Utilizing non-plated composite shells from the mil-spec 38999 series along with low cost insert components brings the robust performance required for the certification of next generation aircraft types.

NEW DESIGN PROTOTYPING:

- Robust aeromotive style non-plated composite shells (non-conductive)
- Meets Military / Aerospace MIL-DTL-38999 requirements for shock, vibration and sealing
- Available in all MIL-DTL-38999 insert configurations
- PC tails, Quadrax, Coax and Fiber Optic contacts available
- High density configurations available
- RoHS compliant
- Shells will accommodate standard MIL-DTL-D38999 accessories
- Rated to 500 mating cycles and temperature of 302° F (150° C)



HOW TO ORDER: ETV38999

Complete Steps 1-7 to Create Your Part Number

1.	2.	3.	4.	5.	6.	7.
Connector Type	Shell Style	Service Class	Shell Size - Insert Arrangement	Contact Type	Alternate Positions	Modification
ETV	06	U	15-35	P	A	

1. Connector Type	
ETV	Ultem, Composite Derivative 38999

2. Shell Style	
P00	Wall Mount Receptacle
06	Straight Plug
07	Jam-nut Receptacle

3. Service Class	
U	Un-plated Ultem

4. Shell Size - Insert Arrangement	
See pages 4-5	Standard 38999 Patterns

5. Contact Type	
P	Pin
S	Socket

6. Alternate Positions	
N	Available in all standard Rotations
A	
B	
C	
D	
E	

*Omit the "N" in the normal coding

ETV38999

Performance Criteria, Specifications

CONTACT RATING**

Contact Size	Test Current (Amps)	Maximum Millivolt Drop Crimp*
	Crimp	
22D	5	73
20	7.5	55
16	13	49
12	23	42
10 (Power)	33	33
8 (Power)	46	26

* When using silver plated wire.

Contact Size	Crimp Well Data	
	Well Diameter	Normal Well Depth
22D	.0345 ± .0010	.141
20	.047 ± .001	.209
16	.067 ± .001	.209
12	.100 ± .002	.209
10 (Power)	.137 ± .002	.355

SERVICE RATING

Service Rating	Suggested Operating Voltage (Sea Level)		Test Voltage (Sea Level)
	AC (RMS)	DC	
M	400	500	1300 VRMS
N	300	450	1000 VRMS
I	600	850	1800 VRMS
II	900	1250	2300 VRMS

Please note that the establishment of electrical factors is left entirely in the designers hands, since he is in the best position to know what voltage, switching surges, transients, etc. can be expected in a particular circuit.

ETV38999

Insert Availability and Identification Chart

Shell Size /Arrg.	Service Rating	Total Contacts	Contact Size							
			22D	20	16	12	12 (Coax)	10 (Power)	8 (Coax)	8†† (Twinax)
9-35	M	6	6							
9-94	M	2		2						
9-98	I	3		3						
11-2★	I	2			2					
11-5	I	5		5						
11-35	M	13	13							
11-98	I	6		6						
11-99	I	7		7						
13-4★	I	4			4					
13-8	I	8		8						
13-13	I, Fiber Optic	4			2*	2				
13-35	M	22	22							
13-98	I	10		10						
13-71	I	2				2				
15-2	I	2						2		
15-5★	II	5			5					
15-15	I	15		14	1					
15-18	I	18		18						
15-19	I	19		19						
15-35	M	37	37							
15-97	I	12		8	4					
15-AC	M	26	24		2					
17-2	M	39	38							1
17-6	I	6				6				
17-8★	II	8			8					
17-22★	Coax	4					2		2	
17-26	I	26		26						
17-35	M	55	55							
17-99	I	23		21	2					
19-11★	II	11			11					
19-31	M	15	12			1			2	
19-32	I	32		32						

* Two size 16 contacts dedicated to fiber optics. Consult Sidney, NY.

† For RG180/U and RG195/U cables only. (Contact Sidney, NY for other cable application).

†† Size 8 Coax and Twinax are interchangeable.

ETV38999

Insert Availability and Identification Chart

Shell Size /Arrg.	Service Rating	Total Contacts	Contact Size							
			22D	20	16	12	12 (Coax)	10 (Power)	8 (Coax)	8†† (Twinax)
19-35	M	66	66							
21-11★	I	11				11				
21-16★	II	16			16					
21-35	M	79	79							
21-39	I	39		37	2					
21-41	I	41		41						
21-75★	M	4								(Note)
23-6★	M	6								6
23-21★	II	21			21					
23-35	M	100	100							
23-53	I	53		53						
23-54	M	53	40		9	4				
23-55	I	55		55						
25-4	I	56		48	8					
25-7	NA	99	97							2
25-8★	NA	8								8
25-11	N	11		2				9		
25-17	M	42	36							6
25-19★	I	19				19				
25-20	N	30		10	13		4			3
25-24★	I	24			12	12				
25-26	I	25		16		5				
25-29★	I	29			29					
25-35	M	128	128							
25-37★	I	37			37					
25-43	I	43		23	20					
25-46	I	46		40	4				2†	
25-61	I	61		61						

* Two size 16 contacts dedicated to fiber optics. Consult Sidney, NY.

† For RG180/U and RG195/U cables only. (Contact Sidney, NY for other cable application).

†† Size 8 Coax and Twinax are interchangeable.

ETV38999

Alternate Inserts Positions

MASTER KEY / KEYWAY POSITION

Shell Size	Key & Keyway Arrangement Identification Letter	AR° or AP° BSC	BR° or BP° BSC	CR° or CP° BSC	DR° or DP° BSC
9	N*	105	140	215	265
	A	102	132	248	320
	B	80	118	230	312
	C	35	140	205	275
	D	64	155	234	304
	E	91	131	197	240
11, 13, and 15	N*	95	141	208	236
	A	113	156	182	292
	B	90	145	195	252
	C	53	156	220	255
	D	119	146	176	298
	E	51	141	184	242
17 and 19	N*	80	142	196	293
	A	135	170	200	310
	B	49	169	200	244
	C	66	140	200	257
	D	62	145	180	280
	E	79	153	197	272
21, 23, and 25	N*	80	142	196	293
	A	135	170	200	310
	B	49	169	200	244
	C	66	140	200	257
	D	62	145	180	280
	E	79	153	197	272

A plug with a given rotation letter will mate with a receptacle with the same rotation letter. The angles for a given connector are the same whether it contains pins or sockets. Master key stays fixed, minor keys rotate. Inserts are not rotated in conjunction with the master key/keyway.

RECEPTACLE
(front face shown)

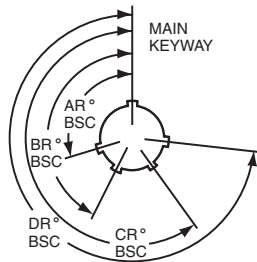

PLUG
(front face shown)

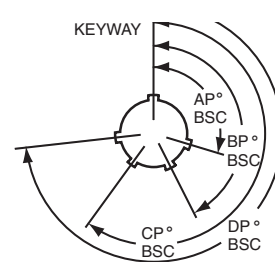

ETV38999

Insert Arrangements

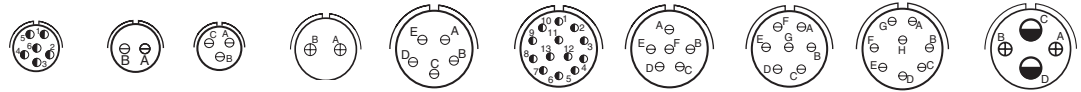

Shell Size & Insert Arrg.	9-35	9-94	9-98	11-2	11-5	11-35	11-98	11-99	13-8	13-13
Service Rating	M	M	I	I	I	M	I	I	I	I, FIBER
Number of Contacts	6	2	3	2	5	13	6	7	8	2 2
Contact Size	22D	20	20	16	20	22D	20	20	20	16 12

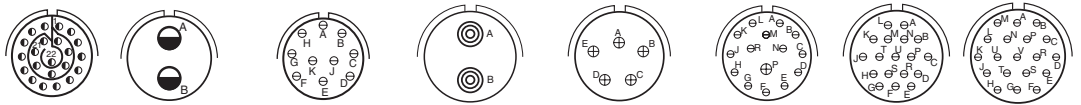

Shell Size & Insert Arrg.	13-35	13-71	13-98	15-2	15-5	15-15	15-18	15-19
Service Rating	M	I	I	I	II	I	I	I
Number of Contacts	22	2	10	2	5	14 1	18	19
Contact Size	22D	12	20	10	16	20 16	20	20

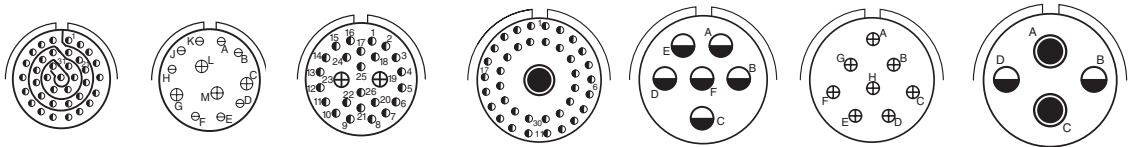

Shell Size & Insert Arrg.	15-35	15-97	15-AC	17-2	17-6	17-8	17-22
Service Rating	M	I	M	M	I	II	Coax
Number of Contacts	37	8 4	24 2	38 1	6	8	2 2
Contact Size	22D	20 16	22D 16	22D 8 Twinax	12	16	12 Coax 8 Coax

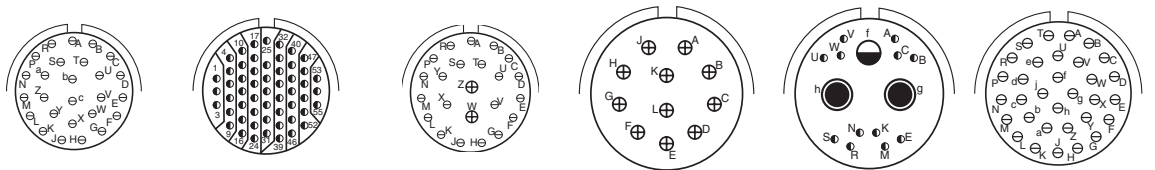

Shell Size & Insert Arrg.	17-26	17-35	17-99	19-11	19-31	19-32
Service Rating	I	M	I	II	M	1
Number of Contacts	26	55	21 2	11	2 1 12	32
Contact Size	20	22D	20 16	16	8 Coax 12 22D	20

Note: Size 8 cavities can be supplied with either twinax or coax per customer requirement.

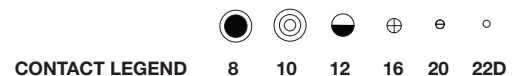

ETV38999

Insert Arrangements

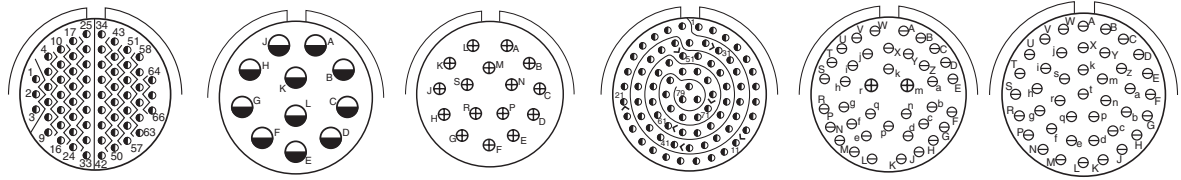

Shell Size & Insert Arrg.	19-35	21-11	21-16	21-35	21-39	21-41	
Service Rating	M	I	II	M	1	I	
Number of Contacts	66	11	16	79	37	2	41
Contact Size	22D	12	16	22D	20	16	20

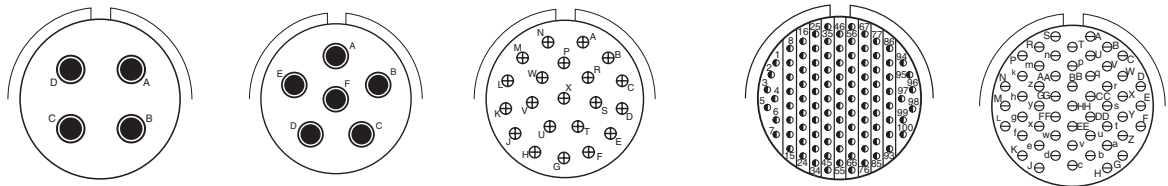

Shell Size & Insert Arrg.	21-75	23-6	23-21	23-35	23-53
Service Rating	N	M	II	M	I
Number of Contacts	4	6	21	100	53
Contact Size	(See Note)	8 Twinax	16	22D	20

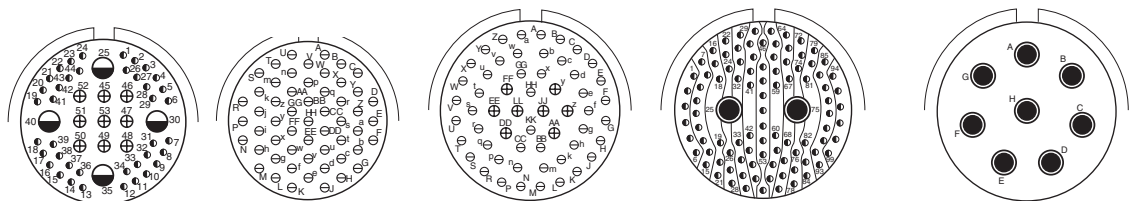

Shell Size & Insert Arrg.	23-54	23-55	25-4	25-7	25-8				
Service Rating	M	I	I	M	Twinax				
Number of Contacts	40	9	4	55	48	8	8		
Contact Size	22D	16	12	20	20	16	22D	8 Twinax	8 Twinax

Note: Size 8 cavities can be supplied with either twinax or coax per customer requirement.

CONTACT LEGEND

8	10	12	16	20	22D

ETV38999

Insert Arrangements

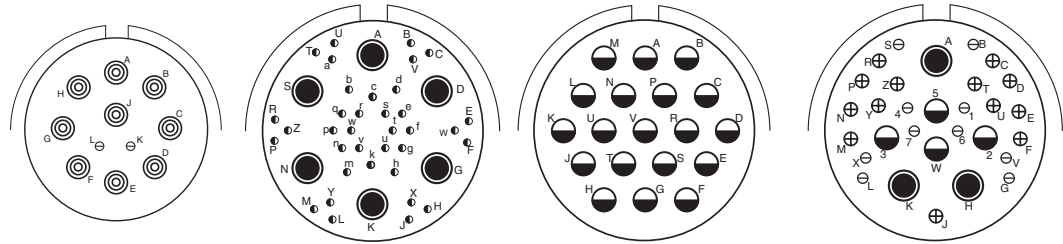

Shell Size & Insert Arrg.	25-11***		25-17		25-19			25-20***			
Service Rating	N		M		I			N			
Number of Contacts	2	9	36	6	19			10	13	3	4
Contact Size	20	10	22D	8 Twinax	12			20	16	8 Twinax	12 Coax
	(With Matched Impedance)										

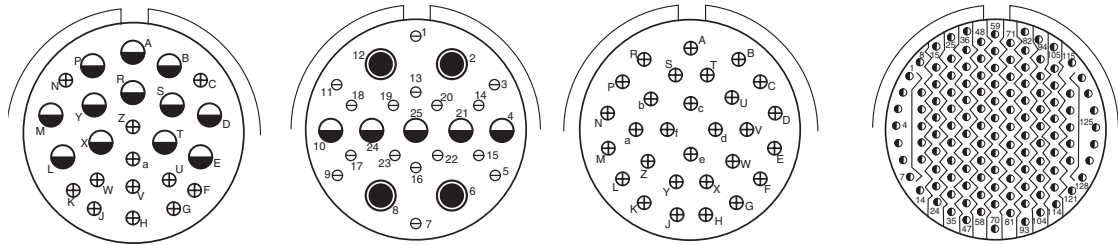

Shell Size & Insert Arrg.	25-24		25-26			25-29			25-35			
Service Rating	I		I			I			M			
Number of Contacts	12	12	16	5	4	29			128			
Contact Size	16	12	20	12	8 Coax	16			22D			

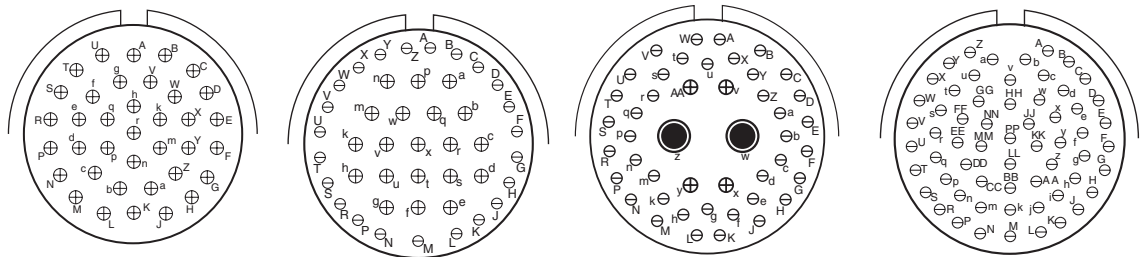

Shell Size & Insert Arrg.	25-37		25-43		25-46			25-61			
Service Rating	I		I		I			I			
Number of Contacts	37		23	20	40	4	2	61			
Contact Size	16		20	16	20	16	8 Coax †	20			

Note: Size 8 cavities can be supplied with either twinax or coax per customer requirement. † Coax contacts for RG180 or RG195 cable.

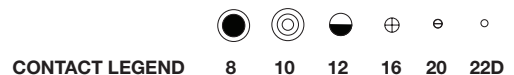

ETV38999

Wall Mounted Receptacle, Composite

ETVP00U

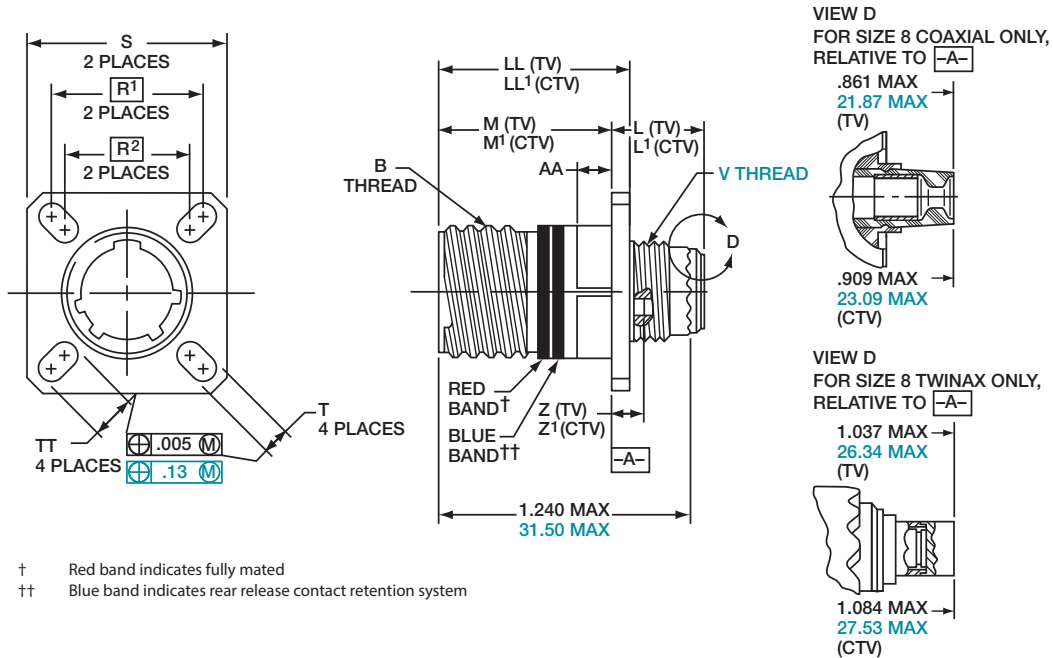

All dimensions for reference only

 Designates true position dimensioning

Inches

Shell Size	B Thread Class 2A 0.1P=0.3L-TS (Plated)	L Max.	M +.000 -.005 (TV)	R¹	R²	S Max.	T +.008 -.006	Z Max.	AA Max. Panel Thickness	LL ±.005	TT +.008 -.006
9	.6250	.514	.775	.719	.594	.948	.128	.198	.234	.913	.216
11	.7500	.514	.775	.812	.719	1.043	.128	.198	.234	.913	.194
13	.8750	.514	.775	.906	.812	1.137	.128	.198	.234	.913	.194
15	1.0000	.514	.775	.969	.906	1.232	.128	.198	.234	.913	.173
17	1.1875	.514	.775	1.062	.969	1.323	.128	.198	.234	.913	.194
19	1.2500	.514	.775	1.156	1.062	1.449	.128	.198	.234	.913	.194
21	1.3750	.545	.745	1.250	1.156	1.575	.128	.228	.204	.911	.194
23	1.5000	.545	.745	1.375	1.250	1.701	.154	.228	.204	.911	.242
25	1.6250	.545	.745	1.500	1.375	1.823	.154	.228	.204	.911	.242

Millimeters

Shell Size	L Max.	M +.00 - .13	R¹	R²	S Max.	T +.20 -.13	V Thread Metric	Z Max.	AA Max.	LL ±.13	TT +.20 -.13
9	13.06	19.69	18.26	15.09	24.1	3.25	M12X1-6g	5.03	5.94	23.19	5.49
11	13.06	19.69	20.62	18.26	26.5	3.25	M15X1-6g	5.03	5.94	23.19	4.93
13	13.06	19.69	23.01	20.62	28.9	3.25	M18X1-6g	5.03	5.94	23.19	4.93
15	13.06	19.69	24.61	23.01	31.3	3.25	M22X1-6g	5.03	5.94	23.19	4.39
17	13.06	19.69	26.97	24.61	33.7	3.25	M25X1-6g	5.03	5.94	23.19	4.93
19	13.06	19.69	29.36	26.97	36.9	3.25	M28X1-6g	5.03	5.94	23.19	4.93
21	13.84	18.92	31.75	29.36	40.1	3.25	M31X1-6g	5.79	5.18	23.14	4.93
23	13.84	18.92	34.93	31.75	43.3	3.91	M34X1-6g	5.79	5.18	23.14	6.15
25	13.84	18.92	38.10	34.93	46.4	3.91	M37X1-6g	5.79	5.18	23.14	6.15

All dimensions for reference only

ETV38999

Straight Plug, Composite

ETV06U

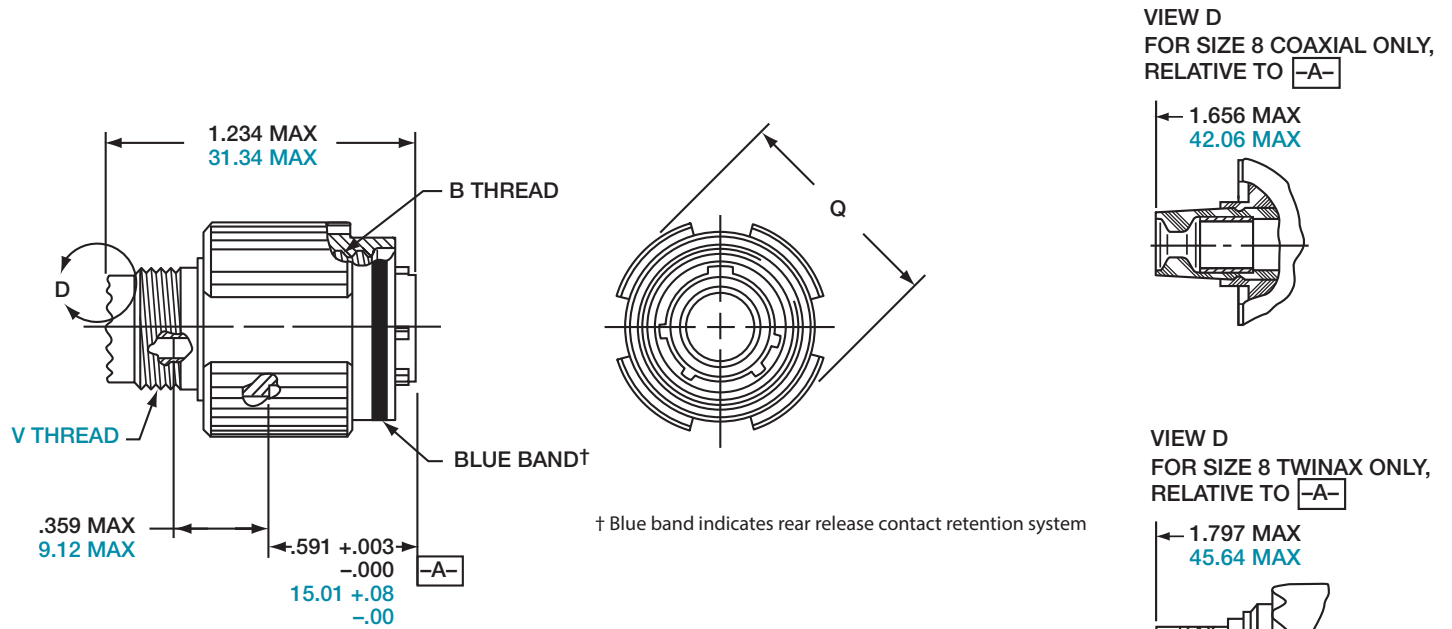

Inches

Shell Size	B Thread 0.1P-0.3L-TS-2B (Plated)	Q Dia. Max.
9	.6250	.858
11	.7500	.984
13	.8750	1.157
15	1.0000	1.280
17	1.1875	1.406
19	1.2500	1.516
21	1.3750	1.642
23	1.5000	1.768
25	1.6250	1.890

All dimensions for reference only

Millimeters

Shell Size	Q Max.	V Thread Metric
9	21.8	M12X1-6g
11	25.0	M15X1-6g
13	29.4	M18X1-6g
15	32.5	M22X1-6g
17	35.7	M25X1-6g
19	38.5	M28X1-6g
21	41.7	M31X1-6g
23	44.9	M34X1-6g
25	48.0	M37X1-6g

ETV38999

Jam Nut Receptacle, Composite

ETV07U

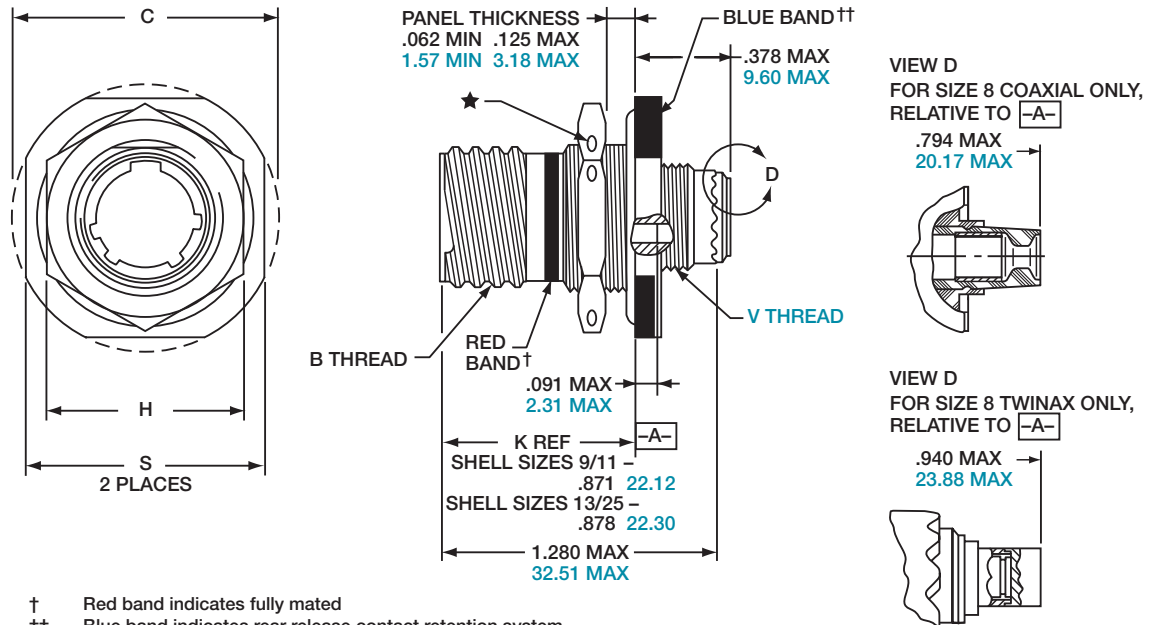

† Red band indicates fully mated
 †† Blue band indicates rear release contact retention system
 ★ .059 dia min.
 1.5 dia min., 3 lockwire holes Formed lockwire hole design (6 holes) is optional

Inches

Millimeters

Shell Size	Inches						Millimeters						
	A• +.010 -.000	B Thread Class 2A 0.1P-0.3L-TS (Plated)	C Max.	H Hex +.017 -.016	S ±.010	T• +.010 -.000	Shell Size	A• +.00 -.25	C Max.	H Hex +.43 -.41	S ±.25	T• +.25 -.00	V Thread Metric
9	.669	.6250	1.199	.875	1.062	.697	9	16.99	30.45	22.23	26.97	17.70	M12X1-6g
11	.769	.7500	1.386	1.062	1.250	.822	11	19.53	35.20	25.40	31.75	20.88	M15X1-6g
13	.955	.8750	1.511	1.250	1.375	1.007	13	24.26	38.38	30.18	34.93	25.58	M18X1-6g
15	1.084	1.0000	1.636	1.375	1.500	1.134	15	27.53	41.55	33.32	38.10	28.80	M22X1-6g
17	1.208	1.1875	1.761	1.438	1.625	1.259	17	30.68	44.73	36.53	41.28	31.98	M25X1-6g
19	1.333	1.2500	1.949	1.562	1.812	1.384	19	33.86	49.50	39.67	46.02	35.15	M28X1-6g
21	1.459	1.3750	2.073	1.688	1.938	1.507	21	37.06	52.65	42.80	49.23	38.28	M31X1-6g
23	1.575	1.5000	2.199	1.812	2.062	1.634	23	40.01	55.85	46.02	52.37	41.50	M34X1-6g
25	1.709	1.6250	2.323	2.000	2.188	1.759	25	43.41	59.00	50.80	55.58	44.68	M37X1-6g

All dimensions for reference only

• D shaped panel cut-out dimensions to prevent connector from turning

ETV38999

Contacts, Sealing Plugs

STANDARD CONTACT FOR ETV38999 SERIES

Contact Size	Pin Part Number	Socket Part Number
8 (Coax)*	21-33102-21	21-33101-21
8 (Twinax)	21-33190-529	21-33191-530
10 (Power)	10-597448-105	10-597449-105
12	10-597448-125	10-597449-125
16	10-597448-165	10-597449-165
20	10-597448-205	10-597449-205
22D	10-597448-725	10-597449-452

Above part numbers include standard 500 cycle finish designation - gold plating over suitable underplate in accordance with SAE AS39029. For other contact options available for use in ETV38999 connectors, (thermocouple) consult Sidney, NY.

SEALING PLUGS

Contact Size	Part Number
8 (Coax)*	10-482099-8
8 (Twinax)	T3-4008-59P
10 (Power)	10-576225
12	10-405996-121
16	10-405996-161
20	10-405996-201
22D	10-405996-221

Notice: Specifications are subject to change without notice. Contact your nearest Amphenol Corporation Sales Office for the latest specifications. All statements, information and data give herein are believed to be accurate and reliable but are presented without guarantee, warranty, or responsibility of any kind, expressed or implied. Statements or suggestions concerning possible use of our products are made without representation or warranty that any such use is free of patent infringement and are not recommendations to infringe any patent. The user should assume that all safety measures are indicated or that other measures may not be required. Specifications are typical and may not apply to all connectors.

AMPHENOL is a registered trademark of Amphenol Corporation. ©2023 Amphenol Corporation REV: 9/5/2023