

## GigaBlox SFP

Compact 5 port 1GBase-T and 1G SFP Ethernet Switch

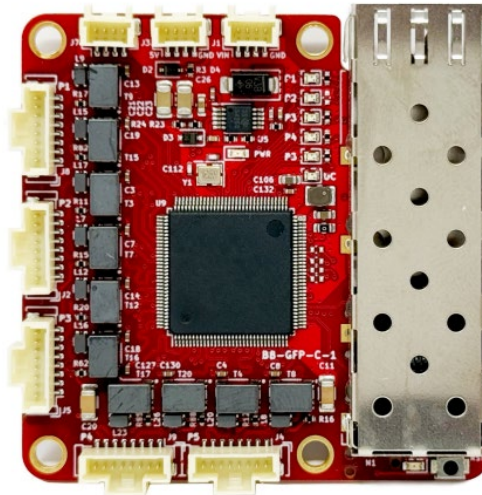

### DESCRIPTION

GigaBlox SFP is a compact embeddable ethernet switch that provides 5 x 10/100/1000BASE-T ports and 1 x 1G SFP port (1000BASE-X) in an ultra-compact, embeddable form factor. GigaBlox SFP is designed to provide very compact, high bandwidth networking combined with a 1G SFP cage to support fiber uplinks. The five onboard copper ports can support standard 10/100/1000BASE-T (via auto-negotiation), while the sixth port is an SFP cage allows modular SFPs to be used to achieve any type of fiber or copper connection on the sixth port.

### FEATURES

- 5 x 10/100/1000BASE-T
- 1 x 1000BASE-X MSA Compliant, IEEE STD 802.3 SFP port to support any 1000BASE-X compatible SFP
- Input voltage range from 5.5V to 60V, reverse polarity and overvoltage protected
- 5V 0.5A output voltage, (alternatively can be used as 5V auxiliary input)
- 52.5mm x 52.5mm board size
- Vibration resistant, positive locking Molex PicoClasp connectors for ports and power
- Automatic MDI-X crossover and polarity correction on the 5 10/100/1000BASE-T ports
- Auto-negotiation on the 5 10/100/1000BASE-T copper with connected devices to achieve maximum speed
- 3.3V UART CLI management (currently unimplemented)
- 4.5 watts maximum power draw (including 1000BASE-X SFP power draw of 1W).
- Plug and play functionality (no configuration necessary)

## HOW TO ORDER

<b>Part Number</b>	CF-02BBGFP	GigaBlox SFP
	CF-02BBGFPNDAA	GigaBlox SFP – NDAA Compliant

## GENERAL SPECIFICATIONS

<b>Voltage Input</b>	5V to 60V DC (65V Absolute maximum)
<b>Supported Protocols</b>	10BASE-T, 100BASE-TX, 1000BASE-T, 1000BASE-X
<b>Power Consumption</b>	4.5W maximum
<b>Weight</b>	25 grams
<b>Size</b>	52.5mm x 52.5mm x 21.5mm (including heatsink)
<b>Operating Temperature</b>	-20 to +85°C
<b>Storage Temperature</b>	-45°C to +125°C

## GENERAL OPERATING INSTRUCTIONS

GigaBlox SFP is designed for use in harsh environments, operating from a nominal supply voltage of 24V, but with the ability to operate from as low as 5V and as high as 60V.

GigaBlox SFP requires no configuration to work, and will automatically begin working as an unmanaged ethernet switch once powered on from a voltage between 5 to 60V. GigaBlox SFP uses 8-way Molex PicoClasp for the 5 10/100/1000BASE-T copper ports on board, while an industry standard SFP cage is used for the 1000BASE-X port.

The SFP port on GigaBlox SFP allows it to provide ethernet connectivity locally while allowing very long range fiber uplinks on the SFP port.

## TYPICAL APPLICATION

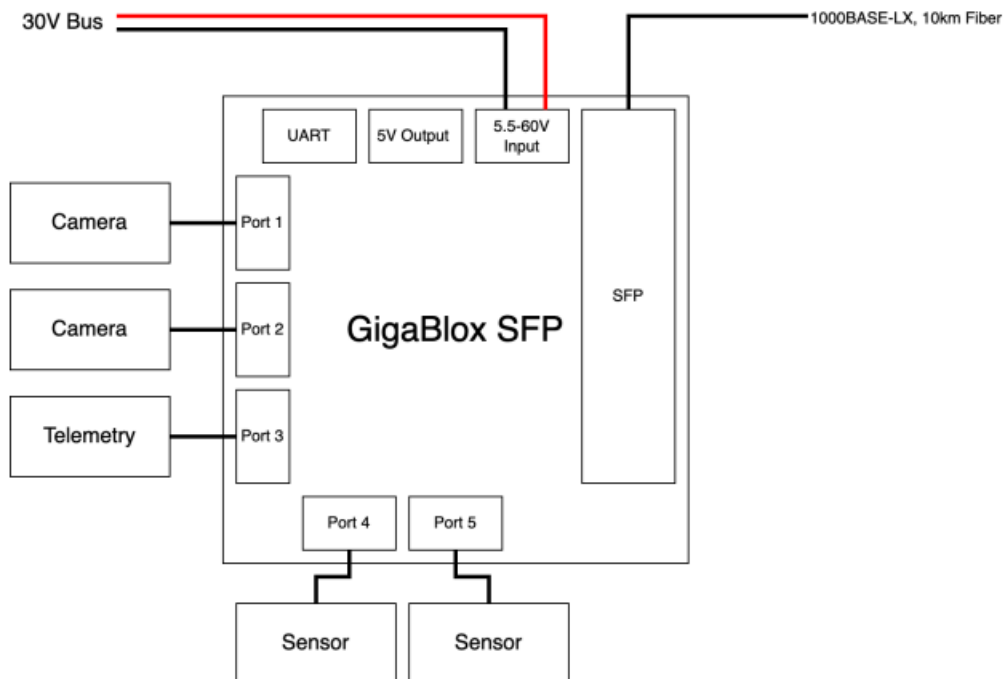

## SAFETY INFORMATION

- This device can operate on voltages near and above 60V. Please read this manual before operating.
- This device is fully functionally tested prior to shipment however in-application testing prior to integration is recommended.
- This device is provided as an electronic circuit board, and requires integration into chassis for full ingress protection.
- Do not use this product in wet environments without integrating into a chassis.
- Do not operate this product beyond the rated temperature and voltages.

## BLOCK DIAGRAM

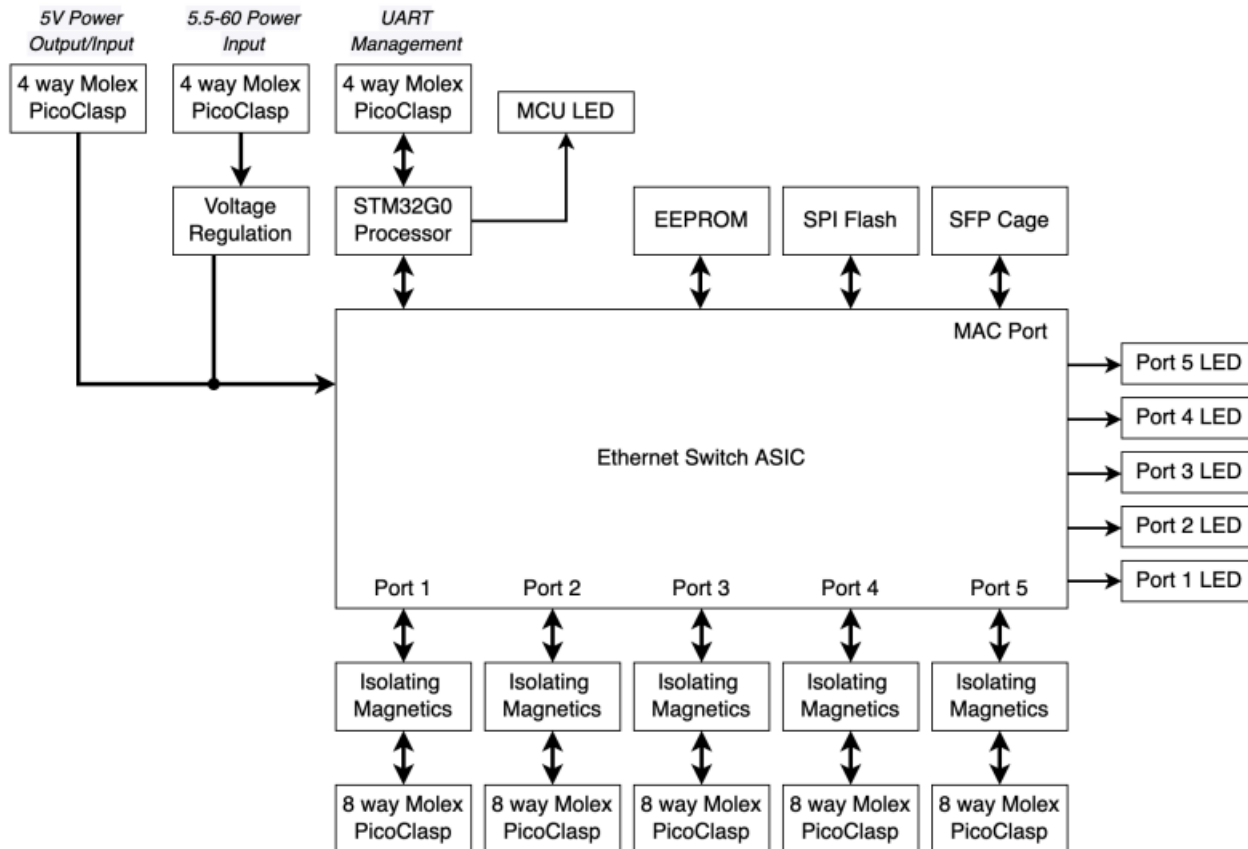

## INCLUDED EQUIPMENT

The product includes the following:

- 1 x GigaSFP Board
- 5 x 8 Way Molex PicoClasp to RJ-45 cable, 0.4 meters (SKU: BB-PCRJ1-8-0.4)
- 1 x 4 Way Molex PicoClasp to Tinned Leads, 0.4 meters (SKU: BB-PCTL1-4-0.4)
- 1 x 13mm x 13mm x 10mm heatsink

## RoHS Certification of Compliance

The GigaBlox SFP complies with the RoHS (Restriction of Hazardous Substances Directive).

## HARDWARE INTERFACE

### Board Map

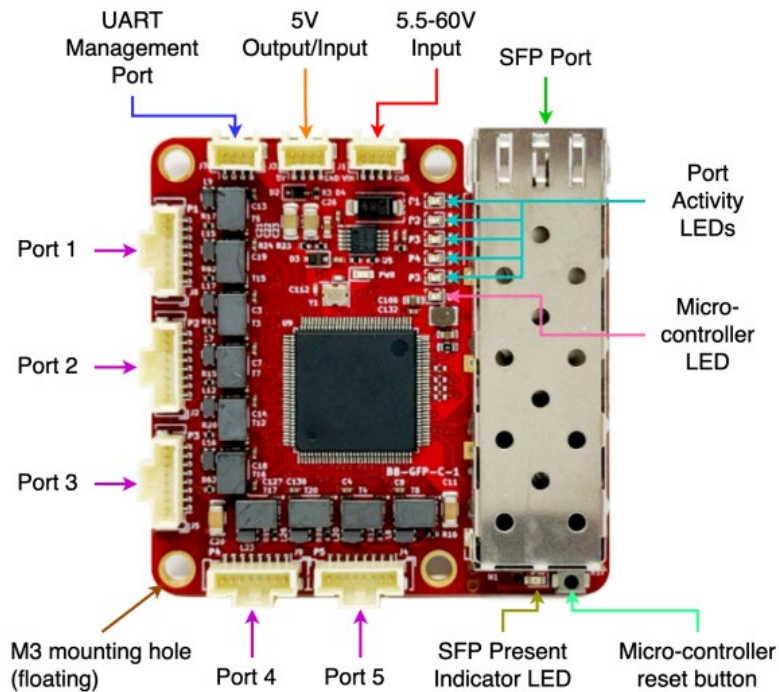

## CONNECTORS AND PINOUTS

### 5.5-60V Voltage Input

A four pin PicoClasp connector is used to supply input voltage to the board.

The voltage input has the following features:

- Voltage input can range from 5.5 to 60V
- Maximum allowable voltage of 65V
- Transient voltage protection above 66.3V
- Reverse polarity protection

The pinout of the voltage input connector is shown in figure 4 below.

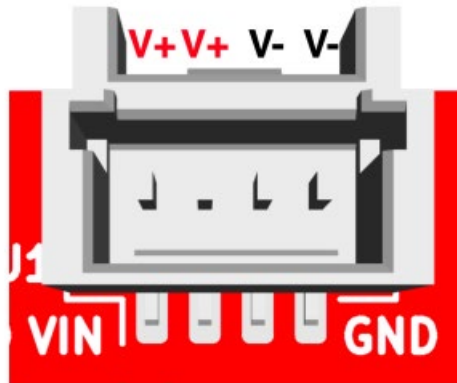

Connector on board	Mating header	Crimp used	Wire used
<a href="#">5019400407</a>	<a href="#">5019390400</a>	<a href="#">5013340000</a>	UL1061, 28AWG

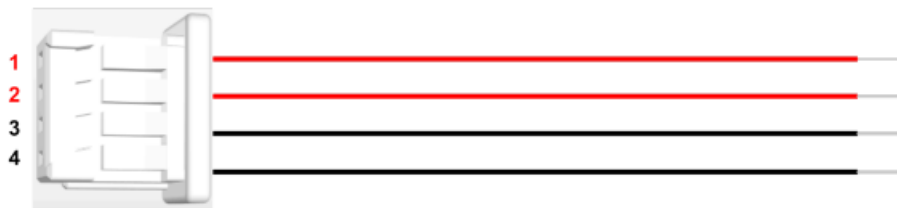

### 10/100/1000BASE-T Copper Ethernet Ports

There are five ethernet connectors on GigaBlox SFP. Each connector has eight pins corresponding to the eight signals required for 1000BASE-T which are A-, A+, B-, B+, D-, D+, C+, C-.

The pin mapping of all eight connectors is identical, and matches the mapping used on all our other products that use 8 way Molex PicoClasp connectors.



Connector on board	Mating header	Crimp used	Wire used
<a href="#">5013310807</a>	<a href="#">5013300800</a>	<a href="#">5013340000</a>	UL1061, 28AWG

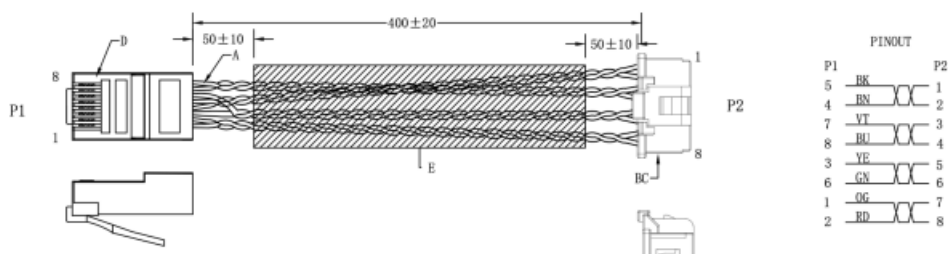

### 5V Voltage Input/Output (Auxiliary 5V input)

When a voltage input is supplied to the 5.5-60V Voltage input, then a 5V, 0.5A capable supply is output onto on this connector. This is a stable 5V rail that can be used to power other devices.

Alternatively, if a 5.5 - 60V rail is unavailable in an application, then a pre-regulated 5V can be supplied to this connector to power the board.

**Warning! You must not supply a 5V to this connector if you are supplying voltage to the 5.5 - 60V connector.**

The pinout of the voltage input connector is shown in figure 9 below.

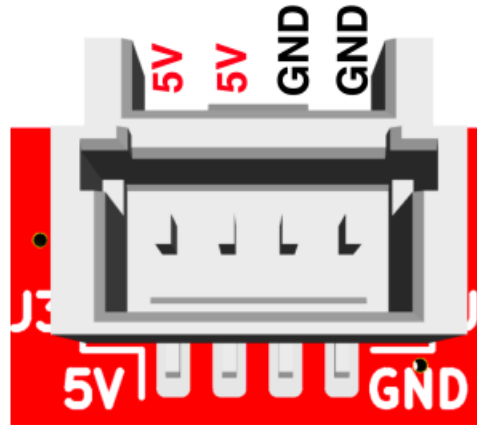

Connector on board	Mating header	Crimp used	Wire used
<a href="#">5019400407</a>	<a href="#">5019390400</a>	<a href="#">5013340000</a>	UL1061, 28AWG

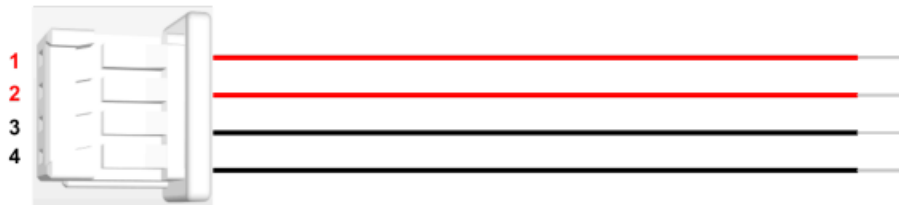

### UART Management Port

A UART port is available on GigaBlox SFP. In future this will allow for switch management features to be available via a command line interface (CLI) (at present this is unimplemented).

The pinout of this connector is shown in figure 10 below

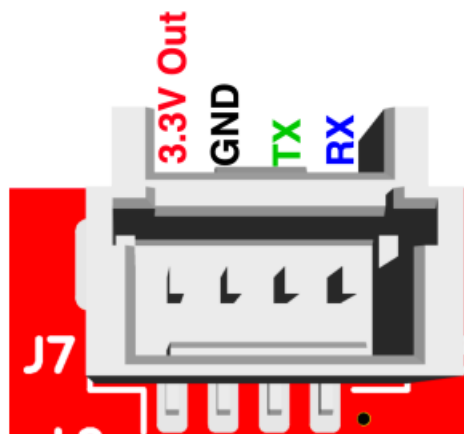

In figure 10 above, RX is an input with respect to GigaBlox SFP, whereas TX is an output with respect to GigaBlox SFP.



## SFP Port

The SFP port is an MSA Compliant, IEEE STD 802.3 compliant SFP cage that allows for 1000BASE-X compatible SFP modules to be plugged into GigaBlox SFP. This allows the integration of multiple types of optical fiber and other physical media to be integrated into the ethernet switch fabric provided by GigaBlox SFP.

## System Information

### Switch Fabric

GigaBlox SFP's ethernet switch fabric has the following specifications.

<b>Packet Buffer Memory</b>	96Kbit
<b>Jumbo Frame Support</b>	9126 Bytes (enabled by default)
<b># of MAC Addresses</b>	2K
<b>Ports 1-5 Capability</b>	10/100/1000BASE-T (Triple speed, autonegotiation)
<b>SFP Port Capability</b>	1000BASE-X
<b>Switching architecture</b>	Non-blocking, 1Gbps on all port simultaneously is supported

## Fundamental Frequencies

The main board level frequencies on GigaBlox SFP are listed below.

- 25MHz - Main crystal oscillator
- 400KHz - 5V Regulator
- 3MHz - 3.3V Regulator
- 3MHz - 1.1V Regulator

## Interfaces

### 5 x 10/100/1000BASE-T Ethernet Ports

There are 5 copper ethernet ports on GigaBlox that can operate in 10BASE-T, 100BASE-TX and 1000BASE-T modes of operation.

#### Auto negotiation

These 5 ports support auto negotiation by default, and will automatically negotiate with any connected device to achieve the highest possible link speed based on the connected device's capabilities.

#### Auto-MDI/X

The 5 ports support Auto-MDI/X by default, meaning the ports will automatically determine whether or not they need to cross over between its pairs as shown in table 6. This means that an external crossover cable is not required when using these ports.

If a connected device cannot automatically correct for crossover the ports on GigaBlox SFP will make the necessary adjustments prior to commencing auto negotiation. If a connected device can automatically correct for crossover, GigaBlox SFP will implement a random algorithm as described in IEEE 802.3 clause 40.4.4 to determine which device performs the crossover.

Pin	MDI			MDIX		
	1000BASE-T	100BASE-TX	10BASE-T	1000BASE-T	100BASE-TX	10BASE-T

MDIP/N[0]	BI_DA±	TX±	TX±	BI_DB±	RX±	RX±
MDIP/N[1]	BI_DB±	RX±	RX±	BI_DA±	TX±	TX±
MDIP/N[2]	BI_DC±	Unused	Unused	BI_DD±	Unused	Unused
MDIP/N[3]	BI_DC±	Unused	Unused	BI_DC±	Unused	Unused

## Polarity Correction

GigaBlox SFP will automatically correct polarity (+ and - wiring mistakes) errors in the receive connections in 1000BASE-T and 10BASE-T. In 100BASE-TX, the polarity does not matter. This allows GigaBlox SFP to compensate for an incorrect polarity.

1 x 1000BASE-X SFP port

The SFP port on GigaBlox SFP supports any MSA compliant SFP module that uses 1000BASE-X. The maximum allowable power consumption of the SFP is 1.65W.

This SFP port requires no configuration, and will automatically form a connection with any other devices connected to the copper ports on GigaBlox SFP.

## UART Management Port

GigaBlox SFP contains a 3.3V level UART port that allows the user to send and receive commands to/from the device. This serial port is connected directly to the STM32 processor and does not connect to the main ethernet switch chip on the board. This will be used to run a command line interface for external user management of the ethernet switch.

Note that both RX and TX are unprotected 3.3V level signals and do not require any external pull ups. For external connections, ensure that GND is common between GigaBlox SFP and the connected device.

GigaBlox SFP contains its own power supply circuitry and can run from any voltage between 5.5 - 60V (or a clean 5V supplied to the auxiliary input). Neither of these input voltages are isolated on the GigaBlox SFP.

## LED port indicator signals

GigaBlox SFP breaks out five LED signals that will flash to show link activity for each of the copper ports. There is no LED signal to show link or activity information on the SFP port.

On revision D of GigaBlox SFP, these LEDs blink green when a port has activity at 1000BASE-T speed. These LEDs blink red when a port has activity at 100BASE-T/10BASE-T speed.

***On revision C of GigaBlox SFP, the color of the LED is mixed and does not indicate speed. It will simply blink either red or green to show activity of either speed. This issue is fixed in GigaBlox SFP revision D.***

Other LEDs There is a single power indicator LED that indicates the presence of 5V on the 5V line on GigaBlox SFP.

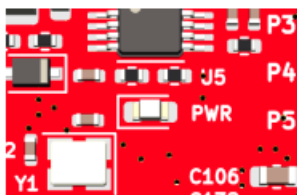

There is a programmable microcontroller dual color (red/green) LED on GigaBlox SFP (see figure 3). At present, this LED is unimplemented.

### Software Interfaces

At present, GigaBlox SFP cannot be managed, however it will later be added to BloxOSLite software for basic switch management.

More information can be found [here](#).

### Device Configuration

Unmanaged Switch To use GigaBlox SFP in an unmanaged application requires no configuration. Simply connect the daughter board and apply a voltage to the voltage input and connect downstream devices.

### Mechanical drawing

