

# GigaStax Rugged

Small 5 Port 10/100/1000Mbps Ethernet Switch

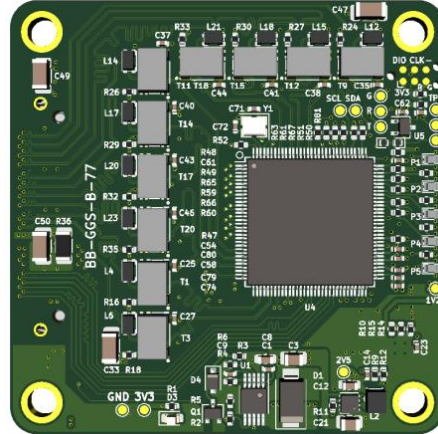

## DESCRIPTION

The Amphenol GigaStax Rugged is a very small layer 2 unmanaged and managed ethernet switch that fits five 10/100/1000Mbps copper ethernet ports in an ultra-compact 48mm x 48mm form factor. The design of GigaStax Rugged is a modular, stackable board which places 5 ethernet ports onto a Samtec Razor Beam (LSHM-140-03.0-L-DV-A-S-K-TR) stackable header. This allows direct integration of GigaStax Rugged into any daughterboard design, allowing full connector and dimensional flexibility

GigaStax Rugged is designed to be a more rugged and more capable upgrade to our GigaBlox product and is designed for space, weight and price-sensitive (SWaP) industrial, mobile and military applications.

## FEATURES

- 5 x 10/100/1000M (10/100/1000BASE-T) non-blocking ethernet ports
- Input voltage range from 5 to 60V
- Reverse protected voltage input
- Transient protected voltage input
- -40°C to 85°C operation range
- 48mm x 48mm board size
- Samtec RAZOR BEAM™ connector for power and ports
- Automatic MDI-X crossover
- Unmanaged (out-the-box) functionality
- Port Activity Indicators
- Embedded STM32L021D4P7 onboard for firmware to implement managed switch functions

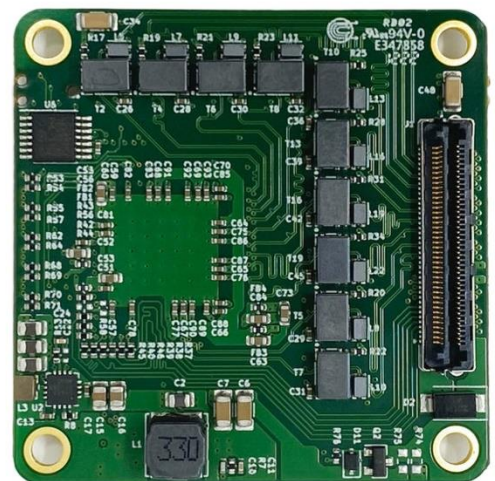

## HOW TO ORDER

<b>Part Number</b>	CF-02BBGGS	GigaStax Rugged
--------------------	------------	-----------------

## GENERAL SPECIFICATIONS

<b>Voltage Input</b>	5V to 60V DC (65V absolute max)
<b>Voltage Output</b>	3.3VDC
<b>Supported Protocols</b>	10/100/1000BASE-T
<b>Number of Ports</b>	5 x 10/100/1000BASE-T
<b>Packet Buffer</b>	256kByte
<b>Power Consumption</b>	1W idle, 3.3W at full data rate
<b>Weight</b>	20 grams
<b>Size</b>	48mm x 48mm x 8.17mm
<b>Operating Temperature</b>	-40°C to +85°C
<b>Storage Temperature</b>	-55°C to +125°C

## GENERAL OPERATING INSTRUCTIONS

GigaStax Rugged is designed for use in harsh environments, operating from a nominal supply voltage of 24V, but with the ability to operate from as low as 5V and as high as 60V.

A daughterboard needs to be used with GigaStax Rugged to provide access to the ports and power on the board. standard daughterboard configurations are provided to enable connectivity on Picoblade connectors (CF-02BBGSP)

To use GigaStax Rugged, first mate the board with a daughterboard then apply an input voltage from 5 to 60V. Then connect external devices and GigaStax Rugged will begin functioning as an unmanaged 10/100/1000Mbit/s network switch.

## SAFETY INFORMATION

- This device can operate on voltages near and above 60V. Please read this manual before operating.
- This device is provided "as is". In-application testing prior to integration is recommended.
- This device is provided as an electronic circuit board, and requires integration into chassis for full ingress protection.
- Do not use this product in wet environments without integrating into a chassis.
- Do not operate this product beyond the rated temperature and voltages.

BLOCK DIAGRAM

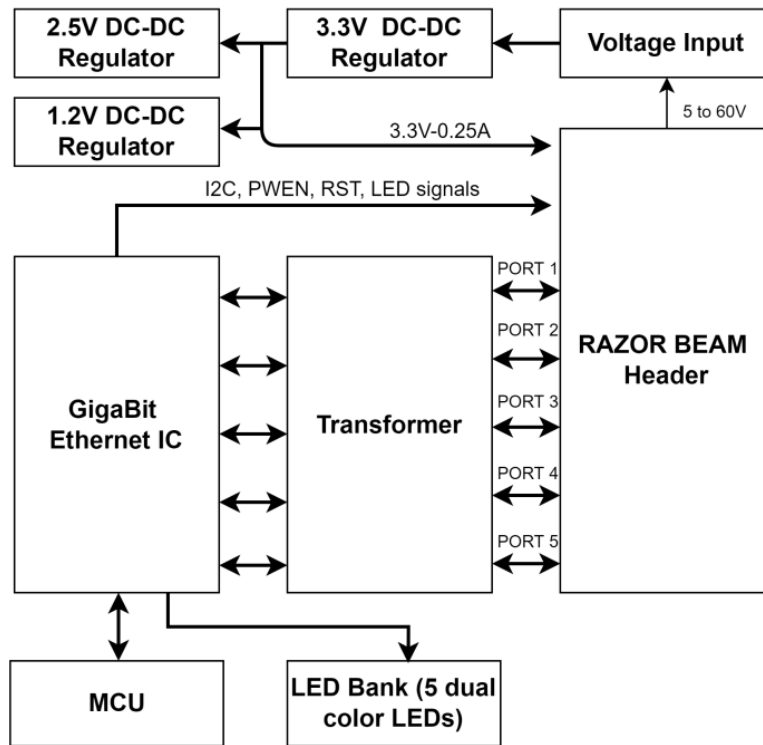

**INCLUDED EQUIPMENT**

The product includes the following:

- 1 x GigaStax Rugged board

**RoHS Certification of Compliance**

The Amphenol SwitchBlox Rugged complies with the RoHS (Restriction of Hazardous Substances Directive) Certificate of Compliance.

## HARDWARE INTERFACE

Board Map (front)

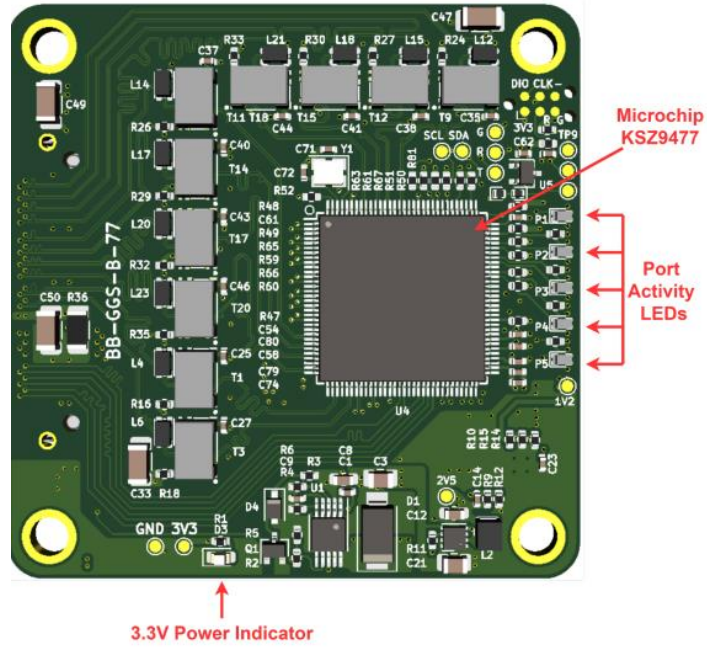

Board Map (back)

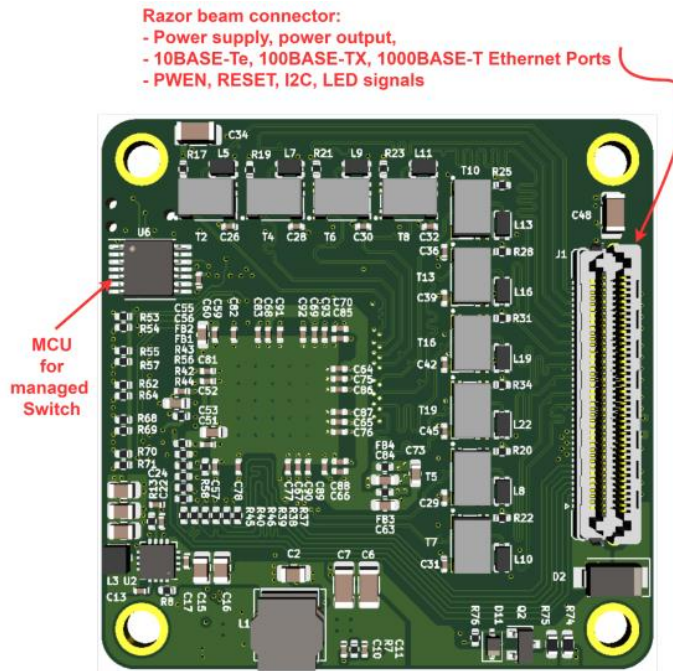

## CONNECTORS AND PINOUTS

### Razor Beam connector

The 5 ports, input voltage, output voltage, RGMII, LED and controls signal are placed onto a Samtec Razor Beam™ (MPN: LSHM-140-03.0-L-DV-A-S-K-TR) stackable header. The Razor Beam connector on the GigaStax Rugged Board is shown below:

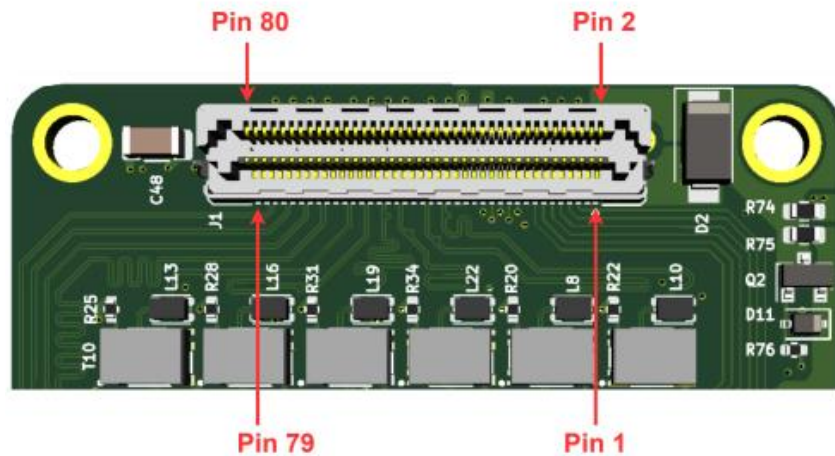

Razor Beam connector

The Razor Beam connector is a hermaphroditic (genderless) connector, meaning the same part is required on the daughterboard for mating. The mating method is shown below.

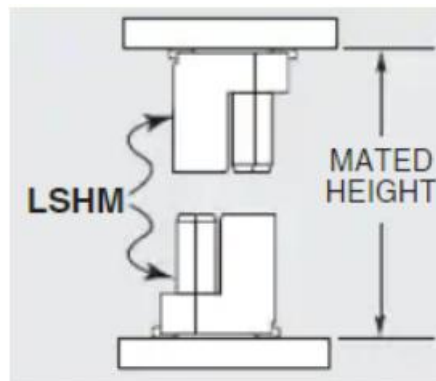

Razor Beam connector self-mating

## PIN MAPPING

Connector A Pin	Connector B Pin	Connector A Pin	Connector B Pin	Connector A Pin	Connector B Pin
1	2	28	27	55	56
2	1	29	30	56	55
3	4	30	29	57	58
4	3	31	32	58	57
5	6	32	31	59	60
6	5	33	34	60	59
7	8	34	33	61	62
8	7	35	36	62	61
9	10	36	35	63	64
10	9	37	38	64	63
11	12	38	37	65	66
12	11	39	40	66	65
13	14	40	39	67	68
14	13	41	42	68	67
15	16	42	41	69	70
16	15	43	44	70	69
17	18	44	43	71	72
18	17	45	46	72	71
19	20	46	45	73	74
20	19	47	48	74	73

21	22	48	47	75	76
22	21	49	50	76	75
23	24	50	49	77	78
24	23	51	52	78	77
25	26	52	51	79	80
26	25	53	54	80	79
27	28	54	53		

Pin mapping between two mated LSHM-140-03.0-L-DV-A-S-K-TR Razor Beam connectors

SIGNAL TO PIN ASSIGNMENTS USED ON GIGASTAX RUGGED

Pin Name	Pin Number	Description
GND	1	Ground
GND	3	Ground
GND	17	Ground
GND	18	Ground
GND	30	Ground
VIN	2	Input supply voltage, 5V to 60V
VIN	4	Input supply voltage, 5V to 60V
+3V3	26	Output 3.3V, maximum 0.25A
+3V3	28	Output 3.3V, maximum 0.25A
GNDREF	31	GND reference for ethernet signals
GNDREF	32	

GNDREF	33	GND reference for ethernet signals
GNDREF	34	
GNDREF	43	
GNDREF	44	
GNDREF	61	
GNDREF	62	
GNDREF	79	
GNDREF	80	
P1_A_P	75	Port 1 1000BASE-T Differential Data Pair A ~ D Note: 100BASE-TX and 10BASE-Te are also supported on the and B pairs.
P1_A_N	77	
P1_B_P	71	
P1_B_N	73	
P1_C_P	67	
P1_C_N	69	
P1_D_P	63	
P1_D_N	65	
P2_A_P	57	Port 2 1000BASE-T Differential Data Pair A ~ D Note: 100BASE-TX and 10BASE-Te are also supported on the and B pairs.
P2_B_P	53	
P2_B_N	55	
P2_C_P	49	
P2_C_N	51	
P2_D_P	45	
P2_D_N	47	



P3_A_P	58	Port 3 1000BASE-T Differential Data Pair A ~ D Note: 100BASE-TX and 10BASE-Te are also supported on the A and B pairs.
P3_A_N	60	
P3_B_P	54	
P3_B_N	56	
P3_C_P	50	
P3_C_N	52	
P3_D_P	46	
P3_D_N	48	
P4_A_P	40	Port 4 1000BASE-T Differential Data Pair A ~ D Note: 100BASE-TX and 10BASE-Te are also supported on the A and B pairs.
P4_A_N	42	
P4_B_P	36	
P4_B_N	38	
P4_C_P	39	
P4_C_N	41	
P4_D_P	35	
P4_D_N	37	
P5_A_P	76	Port 5 1000BASE-T Differential Data Pair A ~ D Note: 100BASE-TX and 10BASE-Te are also supported on the A and B pairs.
P5_A_N	78	
P5_B_P	72	
P5_B_N	74	
P5_C_P	68	
P5_C_N	70	
P5_D_P	64	

P5_D_N	66	*Port 5
P6_RXD0	5	RGMII Port 6 Receive Data bus bit 0
P6_RXD1	7	RGMII Port 6 Receive Data bus bit 1
P6_RXD2	9	RGMII Port 6 Receive Data bus bit 2
P6_RXD3	11	RGMII Port 6 Receive Data bus bit 3
P6_RX_CTL	13	RGMII Port 6 Receive Control output
P6_RXC	15	RGMII Port 6 125/25/2.5MHz Receive Clock output
P6_TXD0	6	RGMII Port 6 Transmit Data bus bit 0
P6_TXD1	8	RGMII Port 6 Transmit Data bus bit 1
P6_TXD2	10	RGMII Port 6 Transmit Data bus bit 2
P6_TXD3	12	RGMII Port 6 Transmit Data bus bit 3
P6_TX_CTL	14	RGMII Port 6 Transmit Control
P6_TXC	16	RGMII Port 6 125/25/2.5MHz Transmit Clock input
SDA	24	I2C SDA Data In/Out
SCL	19	I2C SCL serial clock
ETH_NRST	20	Active low system reset
PW_EN	22	GigaStax power control. Low logic (Ven < 0.5V) or Floating (Default) is enabled. High logic (Ven > 1.4V) is disabled
LED1_1	29	Port 1 LED Indicator 1
LED2_1	21	Port 2 LED Indicator 1
LED3_1	23	Port 3 LED Indicator 1
LED4_1	25	Port 4 LED Indicator 1
LED5_1	27	Port 5 LED Indicator 1

## SWD Programming Header

A programming header on the front of the board allows the STM32L021D4P7 on GigaStax Rugged to be programmed over SWD.

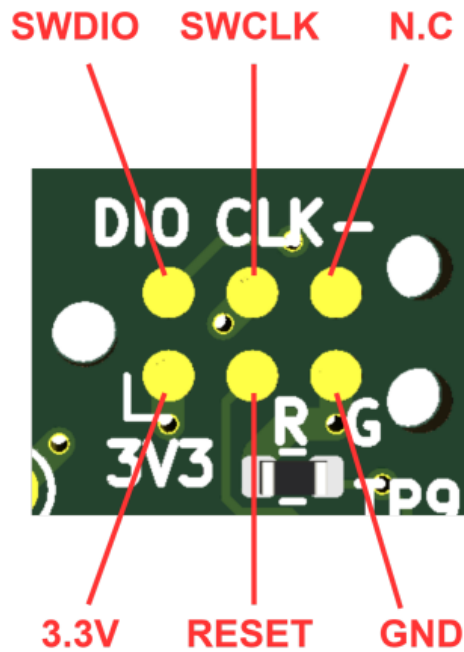

SWD programming header pinout

This header allows access to the SWD port on the onboard STM32 microcontroller, and requires the use of a 6-pin needle adapter.

## Other Interfaces

There are six LEDs on GigaStax Rugged in total. Five of these LEDs are dual color LEDs, meaning there are a total of eleven LED signals on this board. Five of the LED signals can be taken off board.

The 3.3V Power Indicator LED (Green) indicates that voltage is present on the 3.3V line. It should be solid green in normal operation.

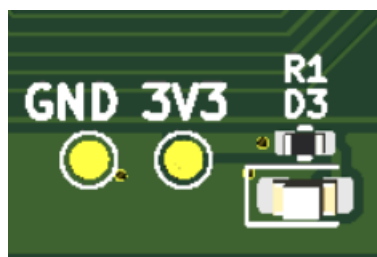

Power Indicator LED

Each Port Activity LED is a Red/Green dual color LED and each corresponds to a specific port. They indicate activity on each port and will blink when there is traffic on a port. They should be solid off when a port is not connected to any device, and they should blink under normal operation (Green blinking indicates a 1000 Mbps connection, Red blinking indicates a 100Mbps connection, Orange blink indicates a 10Mbps connection). A solid on LED indicates Link/No Activity.

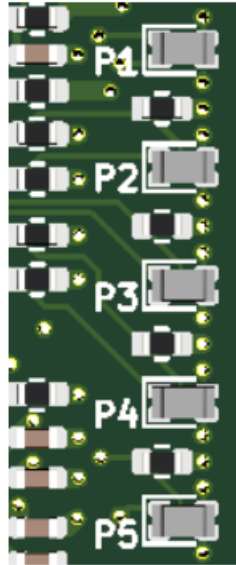

Port Activity Dual Red/Yellow-Green LED

### Daughterboard and Reference Design

StaxPico (GigaStax Picoconn Daughterboard) GigaStax Picoconn is a simple breakout board for GigaStax Rugged that routes the 5 ports, I2C, control signals and Power to Molex Pico-Blade connectors; RGMII signals to FFC connector.

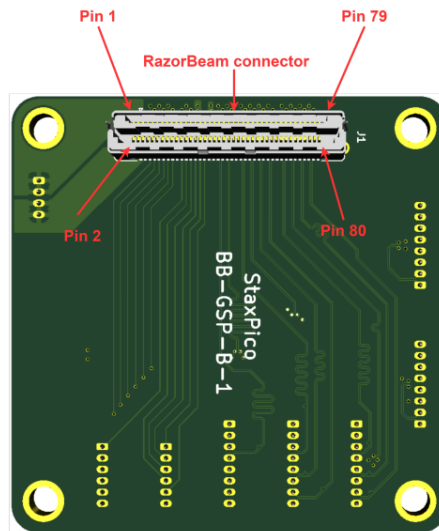

GigaStax Rugged PicoConn Board Map (front)

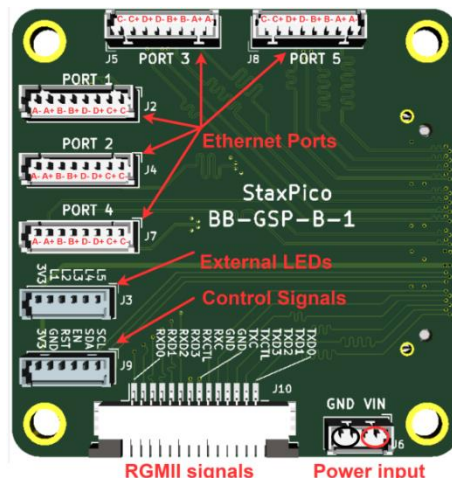

GigaStax Rugged PicoConn Board Map (back)

The mapping of Port and Power connectors is identical to the mapping used on our GigaBlox board, thus the cables can be used interchangeably with GigaBlox.

GigaStax Rugged Picoconn exposes RGMII on a FFC connector, this allows two boards to be connected to form a 10 port switch.

### Associated Components

Connector used on board	14 position FFC cable
1-84953-4	0151670291

An External LED header allows port activity indicator signals can be brought off – board for integration into a chassis. The LED signals are provided in a common anode configuration. The anode of all external LEDs should connect to the 3.3V on the External LED header, and the cathode of the external LED should connect to the corresponding “Lx” connection on the header.

### Associated Components

Connector used for LED signals	Cable assembly	Housing
530470610	0151340603	0510210600

## Signal Mapping To Use On Any Daughterboard For Gigastax Rugged

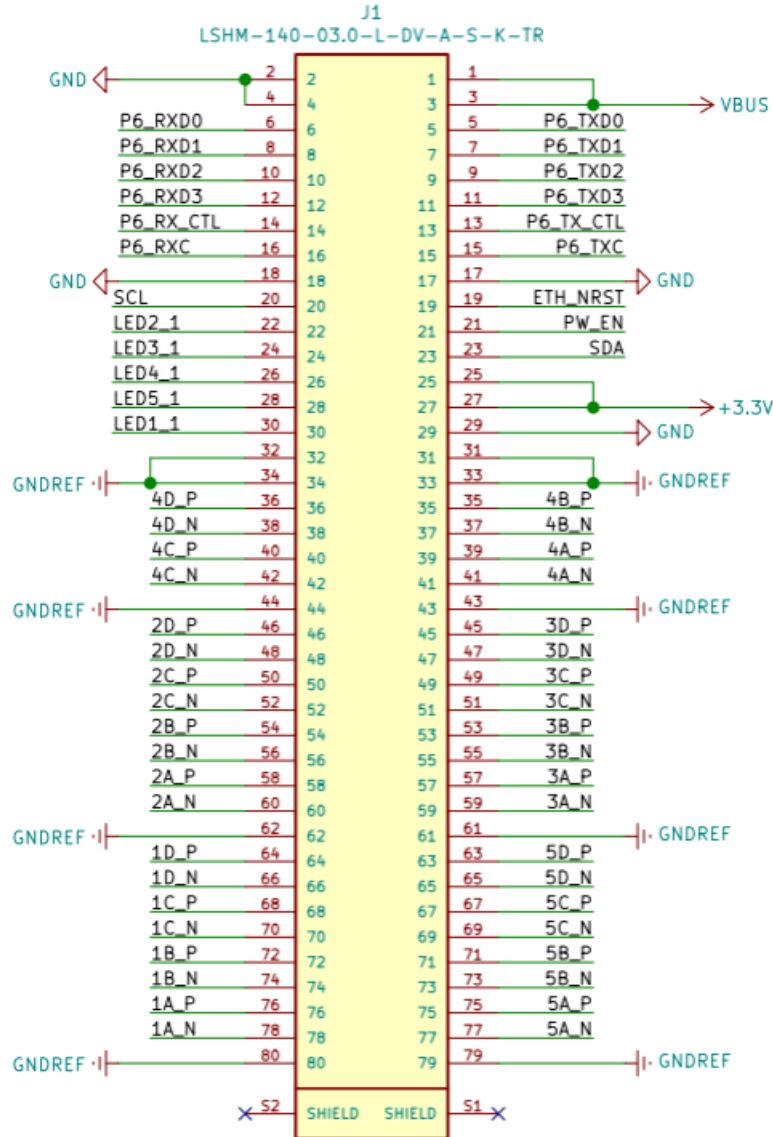

Razor Beam connector on Daughterboard

## Software Interfaces

There is currently no software interface on GigaStax Rugged. It functions solely as an unmanaged switch.

## Device Configuration

### Unmanaged Switch

To use GigaStax Rugged in an unmanaged application requires no configuration. Connect a voltage to the voltage input and connect downstream devices.

## Device Characteristics

### Operating Conditions

#### Absolute Maximum Ratings

Operating in these ranges will reduce the lifetime of the device

Voltage Input Maximum	65V
Storage Temperature	-55°C to +125°C
Operating Temperature	-40°C to +85°C

Notice: Specifications are subject to change without notice. Contact your nearest Amphenol Corporation Sales Office for the latest specifications. All statements, information and data given herein are believed to be accurate and reliable but are presented without guarantee, warranty, or responsibility of any kind, expressed or implied. Statements or suggestions concerning possible use of our products are made without representation or warranty that any such use is free of patent infringement and are not recommendations to infringe any patent. The user should assume that all safety measures are indicated or that other measures may not be required. Specifications are typical and may not apply to all connectors.

AMPHENOL is a registered trademark of Amphenol Corporation.

©2023 Amphenol Corporation REV: PRELIMINARY

# Amphenol

MILITARY HIGH SPEED

40-60 Delaware Avenue

Sidney, NY 13838

[amphenol-aerospace.com](http://amphenol-aerospace.com) | [amphenolmao.com](http://amphenolmao.com)