

GigaStax Rugged PicoConn

Compact 11 Port Module with 1Gbps and 10Gbps Ethernet



DESCRIPTION

The Amphenol UbiSwitch is a compact embeddable ethernet switch module that houses 8 x 1GBASE-T ports and 3 10G MAC ports, designed for challenging environments.

UbiSwitch is a modular board and must be mated with a baseboard to provide a power supply and connector breakout. This allows UbiSwitch to form the heart of any flexible ethernet system through a custom baseboard design. UbiSwitch can be used immediately with the UbiConn board, which provides a plug-and-play ethernet switch solution with 8 x 1Gbps PHY ports and 3 x 10Gbps SFP+ ports.

When used with UbiConn, UbiSwitch does not require any configuration or software to function. When used with a custom baseboard that uses different ethernet hardware on the 10G MAC ports (eg, 10GBASE-T copper PHYs), UbiSwitch requires modification to its firmware to run correctly. Static firmware configuration can be used, or it can be configured dynamically over serial using Switch Management software.

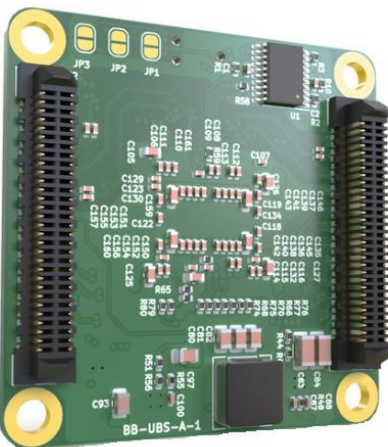

FEATURES

- 3 x 10GBASE-R/XGMII ethernet ports (universal 10Gbps media connectivity)
- 8 x 10/100/1000BASE-T ethernet ports
- Input voltage range from 5V to 60V
- 42mm x 42mm board size
- Samtec EDGE RATE® rugged modular connector for interconnection to baseboard
- Less than 5 Watts maximum power draw

FEATURES Cont.

- Automatic MDI-X crossover and polarity correction on the 8 10/100/1000BASE-T ports
- Auto-negotiation on all ports with connected devices to achieve maximum speed
- Onboard STM32 microcontroller for static firmware configuration
- Onboard STM32 microcontroller for dynamic serial configuration
- Three onboard solder jumpers for static (in-the-field) firmware configuration
- Plug and play functionality (no configuration necessary) when used with UbiConn (or a functional equivalent to UbiConn)

HOW TO ORDER

Part Number	CF-02BBUBS	UbiSwitch Module 3
--------------------	------------	--------------------

GENERAL SPECIFICATIONS

Voltage Input	5V to 60V DC (65V absolute max)
Supported Protocols	10BASE-T, 100BASE-TX, 1000BASE-T, 2.5GBASE-T, 5GBASE-T, 10GBASE-T, 10GBASE-R
Power Consumption	4.6W maximum
Weight	20 grams
Size	42mm x 42mm x 9.8mm (without heatsink)
Operating Temperature	-70°C to +110°C
Storage Temperature	-70°C to +125°C

GENERAL OPERATING INSTRUCTIONS

UbiSwitch is designed for use in harsh environments, operating from a nominal supply voltage of 24V, but with the ability to operate from as low as 5V and as high as 60V.

A baseboard needs to be used with UbiSwitch to provide access to the ports and power on the board. To use UbiSwitch, first mate the board with a baseboard then apply an input voltage from 5 to 60V. If the UbiConn baseboard is used (or any baseboard that incorporates SFPs on the 10G ports) then UbiSwitch will begin functioning as an unmanaged switch on all 11 ports without any configuration necessary. If a different baseboard is used (crucially, if it uses different 10G media on the 10G ports), then UbiSwitch will require configuration either via a static firmware update or a dynamic serial configuration.

SAFETY INFORMATION

- This device can operate on voltages near and above 60V. Please read this manual before operating.
- This device is provided “as is”. In-application testing prior to integration is recommended.
- This device is provided as an electronic circuit board and requires integration into chassis for full ingress protection.
- Do not use this product in wet environments without integrating into a chassis.
- Do not operate this product beyond the rated temperature and voltages.

BLOCK DIAGRAM

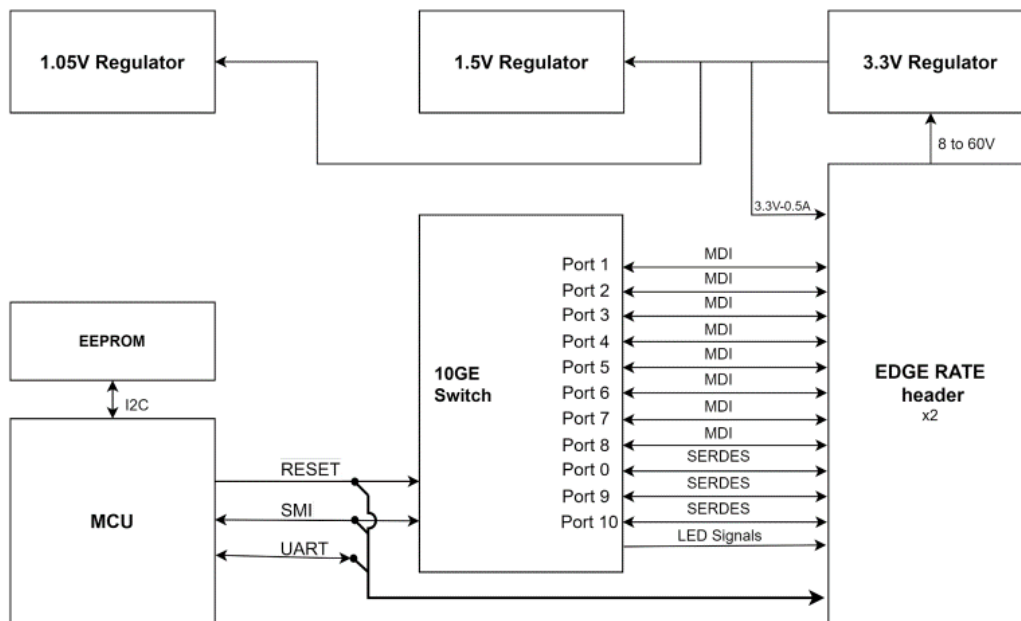

INCLUDED EQUIPMENT

The product includes the following:

- 1 x UbiSwitch Module
- 1 x UbiSwitch Heatsink

RoHS Certification of Compliance

The Amphenol SwitchBlox Rugged complies with the RoHS (Restriction of Hazardous Substances Directive) Certificate of Compliance.

HARDWARE INTERFACE

Board Map (front)

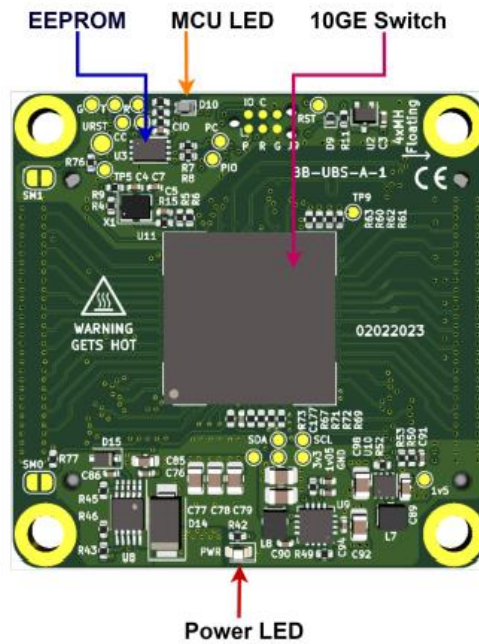

Board Map (back)

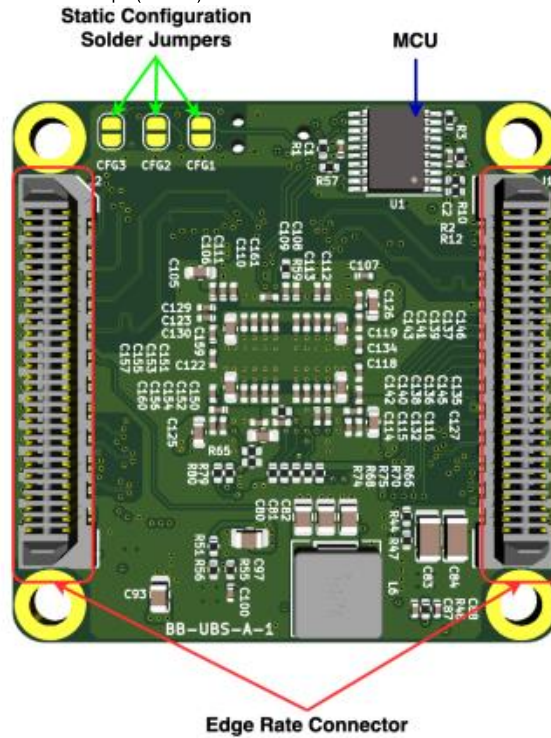

CONNECTORS AND PINOUTS

Edge Rate connector

8 ports, 3 SerDES, SMI, LED signals, UART, input voltage and output voltage are placed onto two Samtec Edge Rate™ stackable headers. The Edge Rate connector on the UbiSwitch Board is shown below. The Edge Rate connector provides a high-quality connection optimized for signal integrity and a 0.8mm spacing for isolation protection.

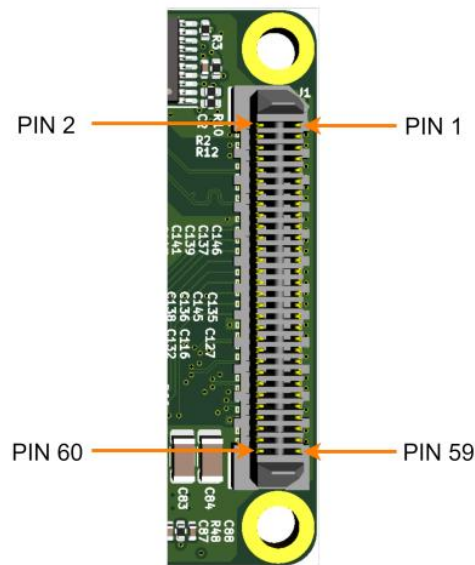

Edge Rate connector

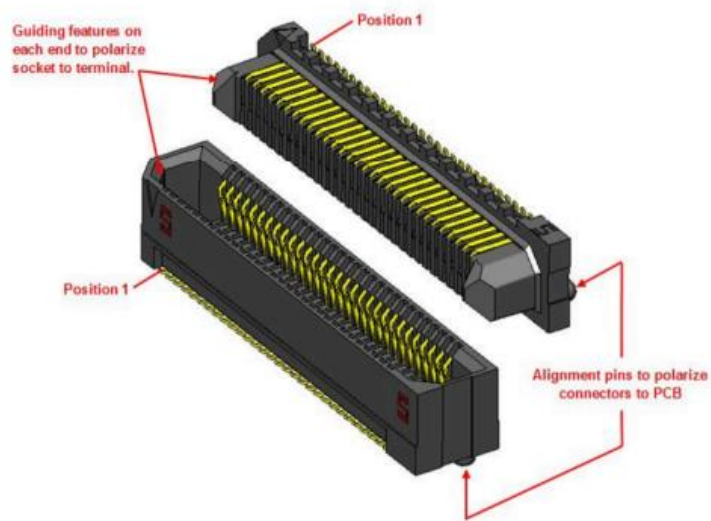

Edge Rate connector mating

SIGNAL TO PIN ASSIGNMENTS

Connector	Pin Name	Pin Number	Description
J1	GND	1	Ground
	GND	2	Ground
	GND	6	Ground
	GND	12	Ground
	GND	18	Ground
	GND	19	Ground
	GND	37	Ground
	GND	38	Ground
	GND	55	Ground
	GND	56	Ground
	GND	57	Ground
	GND	59	Ground
	VBUS	58	Input supply voltage, 5V to 60V
	VBUS	60	Input supply voltage, 5V to 60V
	P1A_P	3	Port 1 1000BASE-T Differential Data Pair A ~ D Note: 100BASE-TX and 10BASE-Te are also supported on the A and B pairs.
	P1A_N	5	
	P1B_P	9	
	P1B_N	7	
	P1C_P	11	
	P1C_N	13	
P1D_P	17		
P1D_N	15		

P2A_P	21	Port 2 1000BASE-T Differential Data Pair A ~ D Note: 100BASE-TX and 10BASE-Te are also supported on the A and B pairs.
P2A_N	23	
P2B_P	27	
P2B_N	25	
P2C_P	29	
P2C_N	31	
P2D_P	35	
P2D_N	33	
P3A_P	39	Port 3 1000BASE-T Differential Data Pair A ~ D Note: 100BASE-TX and 10BASE-Te are also supported on the A and B pairs.
P3A_N	41	
P3B_P	45	
P3B_N	43	
P3C_P	47	
P3C_N	49	
P3D_P	53	
P3D_N	51	
P4A_P	40	Port 4 1000BASE-T Differential Data Pair A ~ D Note: 100BASE-TX and 10BASE-Te are also supported on the A and B pairs.
P4A_N	42	
P4B_P	46	
P4B_N	44	
P4C_P	48	
P4C_N	50	
P4D_P	54	

P4D_N	52	Cont.
P0TX_P	14	SerDES Port 0 Transmit Data bus positive
P0TX_N	16	SerDES Port 0 Transmit Data bus negative
P0RX_P	8	SerDES Port 0 Transmit Data bus positive
P0RX_N	10	SerDES Port 0 Transmit Data bus negative
R0_LED	20	Parallel multiplexed LED outputs. These active low LED pins directly drive the port's LEDs supporting a range from 1 to 20 LEDs in a multiplexed fashion. In this mode the cathode of each LED connects to these pins through a series current limiting resistor. The anode of each LED connects to one of the Cx_LED pins below
R1_LED	22	
R2_LED	24	
R3_LED	26	
R4_LED	28	
C0_LED	30	Connect to the anode of LED column 0 for each row
C1_LED	32	Connect to the anode of LED column 1 for each row
C2_LED	24	Connect to the anode of LED column 2 for each row
C3_LED	36	Connect to the anode of LED column 3 for each row
SE_SCLK	4	Synchronous Ethernet Source Clock. This is a 25 MHz reference clock which can be used as a synchronous clock input from the board or system. This signal must come from a high quality clock conditioning circuit or Synchronous Ethernet PLL.

Connector	Pin Name	Pin Number	Description
J2	GND	1	Ground
	GND	2	Ground
	GND	7	Ground
	GND	13	Ground
	GND	19	Ground
	GND	20	Ground
	GND	25	Ground
	GND	37	Ground
	GND	38	Ground
	GND	55	Ground
	GND	56	Ground
	GND	58	Ground
	GND	60	Ground
	+3V3	57	Output 3.3V, maximum 0.5A
	+3V3	59	Output 3.3V, maximum 0.5A
	P5A_P	53	Port 5 1000BASE-T Differential Data Pair A ~ D Note: 100BASE-TX and 10BASE-Te are also supported on the A and B pairs.
	P5A_N	51	
	P5B_P	47	
	P5B_N	49	
	P5C_P	45	
P5C_N	43		
P5D_P	39		
P5D_N	41		

P6A_P	54	Port 6 1000BASE-T Differential Data Pair A ~ D Note: 100BASE-TX and 10BASE-Te are also supported on the A and B pairs.
P6A_N	52	
P6B_P	48	
P6B_N	50	
P6C_P	46	
P6C_N	44	
P6D_P	40	
P6D_N	42	
P7A_P	36	Port 7 1000BASE- T Differential Data Pair A ~ D Note: 100BASE-TX and 10BASE-Te are also supported on the A and B pairs.
P7A_N	34	
P7B_P	30	
P7B_N	32	
P7C_P	28	
P7C_N	26	
P7D_P	22	
P7D_N	24	
P8A_P	18	Port 8 1000BASE-T Differential Data Pair A ~ D Note: 100BASE-TX AND 10BASE-TE are also supported on the A and B pairs.
P8A_N	16	
P8B_P	12	
P8B_N	14	
P8C_P	10	
P8C_N	8	
P8D_P	4	
P8D_N	6	

P9TX_P	17	SerDES Port 9 Transmit Data bus positive
P9TX_N	15	SerDES Port 9 Transmit Data bus negative
P9RX_P	23	SerDES Port 9 Receive Data bus positive
P9RX_N	21	SerDES Port 9 Receive Data bus negative
P10TX_P	5	SerDES Port 10 Transmit Data bus positive
P10TX_N	3	SerDES Port 10 Transmit Data bus negative
P10RX_P	11	SerDES Port 10 Receive Data bus positive
P10RX_N	9	SerDES Port 10 Receive Data bus negative
ETH_RST	27	Active low system reset, (internal pulled up). Will hardware reset the ethernet switch chip, but not the onboard microcontroller.
MDC_CPU	33	Management Data Clock for the ethernet switch, Slave. MDC_CPU is the reference clock input for the serial management interface (SMI) that connects to an external SMI master, typically a CPU. A continuous clock stream is not expected. The maximum frequency supported is 20.0 MHz The CPU's SMI interface is used to access the device's registers but it cannot be used until the device's INTn pin becomes active low. We do not recommend using this bus in your application for switch configuration, instead, the serial port should be used.
MDIO_CPU	35	Management Data I/O, Slave. MDIO_CPU is used to transfer management data in and out of the device synchronously to MDC_CPU. We do not recommend using this bus in your application for switch configuration, instead, the serial port should be used.
USART2_RX	29	Input Microcontroller UART RX line. This connects directly to the onboard microcontroller and is used to send serial commands to the board for switch configuration.
USART2_TX	31	Output Microcontroller UART TX line. This connects directly to the onboard microcontroller and is used to receive serial commands from the board relating to switch configuration.

SWD Programming Header

A programming header on the front of the board allows the STM32 on UbiSwitch to be programmed over SWD.

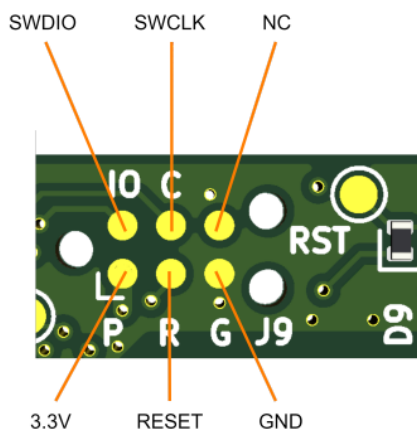

SWD programming header pinout

This header allows access to the SWD port on the onboard STM32 microcontroller and requires the use of a 6-pin needle adapter such as the J-Link 6-pin needle adapter along with an in-circuit programmer.

In most cases, we do not recommend directly uploading firmware to UbiSwitch for switch configuration. Instead, we recommend using our serial interface which can achieve switch configuration without needing to change or upload firmware.

SYSTEM INFORMATION

UbiSwitch has the following capabilities

Switch Fabric

Packet Buffer Memory	2Mbit
Jumbo Frame Support	10K Bytes (enabled by default)
# of MAC Addresses	16K
Ports 1-8 Capability	10/100/1000BASE-T (Triple speed, auto negotiation)
Port 0 Capability	RGMII, RMII, MII, SGMII, 5GBASE-X, SFI, USXGMII
Port 9 & 10 Capability	SGMII, 5GBASE-X, SFI, USXGMII

Switch Management

Link Aggregation (LAG/Port Trunking)	Yes
802.1p, TOS/DS/ IPv6 TC, MAC	Yes
Programmable Weighting	Yes
Port-based VLANs	Yes
802.1Q VLANs	Yes, 4096
Double Tagging (Q in Q)	Yes
LMP Entries	256
802.1BR ECID	4K
Wake on LAN/ Wake On Frame	Yes
Remote Mgmt/Ethertype DSA	Yes
TCAM	Yes
802.1D/s/w Spanning Tree	Yes
802.1X Port & MAC Authentication	Yes
Port Mirroring	Yes
IGMP/MLD Snooping	Yes
802.1AS / Qat / Qav / 1588v2	Yes
802.1Qbv	Yes
Synchronous Ethernet	Yes
Cut Through Switch Fabric	Yes

Fundamental Frequencies

The main board level frequencies on UbiSwitch are listed below.

- 25MHz - Main MEMS oscillator
- 403KHz - 3.3V Regulator
- 3MHz - 1.5V Regulator
- 1.29MHz - 1.05V Regulator
- 597KHz - 3.3V Regulator (for SFP)

Interfaces

8 x 10/100/1000BASE-T Ethernet Ports

There are 8 copper ethernet ports on UbiSwitch that can operate in 10BASE-T, 100BASE-TX and 1000BASE-T modes of operation.

Auto negotiation

These 8 ports support auto negotiation and will automatically negotiate with any connected device to achieve the highest possible link speed based on the connected device's capabilities. This is the default configuration of these ports on UbiSwitch. Auto negotiation can be disabled through switch configuration, and the port can be fixed to a particular speed. In most cases it is not advisable to do this since it is more simple to let the auto negotiation protocol handle differences in port capabilities.

Auto-MDI/X

The 8 ports support Auto-MDI/X by default, the ports will automatically determine whether or not they need to cross over between its pairs as shown in the table below. An external crossover cable is not required when using these ports.

If a connected device cannot automatically correct for crossover, the ports on UbiSwitch will make the necessary adjustments prior to commencing auto negotiation. If a connected device can automatically correct for crossover, UbiSwitch will implement a random algorithm as described in IEEE 802.3 clause 40.4.4 to determine which device performs the crossover. This feature can be disabled through switch configuration.

MDI/MDX Pin Mapping

Pin	MDI			MDIX		
	1000BASE-T	100BASE-TX	10BASE-T	T 1000BASE-T	T 100BASE-TX	10BASE-T
MDIP/N[0]	BI_DA±	TX±	TX±	BI_DB±	RX±	RX±
MDIP/N[1]	BI_DB±	RX±	RX±	BI_DA±	TX±	TX±
MDIP/N[2]	BI_DC±	Unused	Unused	BI_DD±	Unused	Unused
MDIP/N[3]	BI_DD±	Unused	Unused	BI_DC±	Unused	Unused

Polarity Correction

UbiSwitch will automatically correct polarity (+ and – wiring mistakes) errors in the receive connections in 1000 BASE-T and 10BASE-T. In 100BASE-TX the polarity does not matter. This allows UbiSwitch to compensate for an incorrect polarity.

3 x 10G MAC ports

Ports 0, 9 and 10 on UbiSwitch are SERDES interfaces that implement MAC ports on the switch. Unlike the 8 x 1G ports described above, they require a physical layer transceiver (PHY) to be converted from a MAC level interface to a field level interface such as 10BASE-T (10Gbps on four copper pairs) or 10GBASE-R (10Gbps backplane for connection to SFP). This allows flexibility on these ports, as any type of PHY can be connected to them to achieve any type of ethernet media connection.

Ports 9 and 10 can support SGMII, 5GBASE-X, SFI and USXGMII while port 0 can support RGMII, RMII, MII, SGMII, 5GBASE-X, SFI and USXGMII. By default, UbiSwitch configures all these ports to operate in SFI mode as 10GBASE-R, which is the required mode when connecting to an external SFP, as is the case on the UbiConn breakout board.

When using these ports to connect to an SFP cage on a baseboard, no configuration is necessary and the ports will work immediately. When using a different PHY on the baseboard, these ports will need specific configuration.

The 10G ports MAC port can integrate with copper PHYs using 100BASE-Tx, 1000BASE-T, 2.5GBASE-T, 5GBASE-T and 10GBASE-T. When integrating with SFPs (as is the case when using UbiSwitch with UbiConn), these ports can also run at 100M, 1G, 2.5G, 5G and 10G, assuming the SFP that is plugged in can also support these speeds.

Serial Port

UbiSwitch contains a serial port that allows the user to send and receive commands to/from the device. This serial port is connected directly to the STM32 microcontroller and does not connect to the main ethernet switch chip on the board. This allows the STM32 to run custom parser firmware that can receive human-readable serial commands and parse them to low level SMI commands to configure the switch.

The onboard STM32 can also store serial commands on an EEPROM on UbiSwitch, allowing for non-volatile configurations to be written to the device over serial.

Note that both RX and TX are 3.3V level signals and do not require any external pull ups. For external connections, ensure that GND is common between UbiSwitch and the connected device.

SMI Port

The SMI port connects directly to the SMI port on the ethernet switch chip and the STM32 microcontroller. It is not recommended to use this for switch configuration as the interface is not human readable, nor are commands able to be stored after a power cycle. This port mainly intended for debugging and for cases where the management device for the switch is intended to reside on the baseboard rather than on UbiSwitch.

Note that both MDIO and MDC are 3.3V level signals and do not require any external pullups. For external connections, ensure that GND is common between UbiSwitch and the connected device.

Power Supply

UbiSwitch contains its own power supply circuitry and can run from any voltage between 5 - 60V. This input voltage is not isolated on the UbiSwitch Module.

LED port indicator signals

UbiSwitch breaks out nine LED signals which, when multiplexed correctly, allow the link and activity from each port to be indicated on LEDs. These signals are available on the stackable header, allowing the baseboard to contain these port LEDs, or allowing an external connector to be added to break-out the LEDs further. On UbiConn, the LED signals are connected to port activity LEDs on the board and broken out to an LED signal breakout header for convenience.

Temperature Sensor

UbiSwitch contains an integrated temperature sensor that can be queried over serial. This allows for monitoring of the junction temperature inside the main switch chip.

Static configuration jumpers

In some production environments, it is desirable to have different static configurations enabled. On UbiSwitch, this can be set up without use of software. UbiSwitch contains three static configuration jumpers that can be set/reset via soldering the jumpers. This allows up to eight different configurations to be selected on UbiSwitch without any software needed in the field. This feature is enabled by custom firmware.

Static Configuration Solder Jumpers

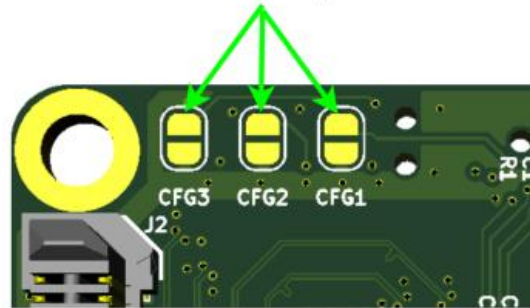

Static configuration headers on UbiSwitch

Solder jumpers are housed on the bottom of UbiSwitch and are not easily visible when UbiSwitch is plugged into a baseboard. This can be mitigated with the onboard microcontroller LED, which can be configured to flash a number of times to indicate the current configuration state based on the jumpers.

Onboard LEDs

There are two LEDs on UbiSwitch in total. A dual color LED and a standard LED making it so that there are three LED signals on this board.

The 3.3V Power Indicator LED (**Green**) indicates that voltage is present on the 3.3V line. During normal operation it will be solid green.

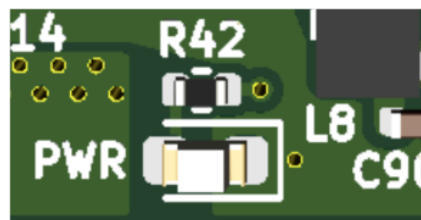

Power Indicator LED

The Microcontroller LED is a **Red/Green** dual color LED with flexible use depending on the microcontroller firmware.

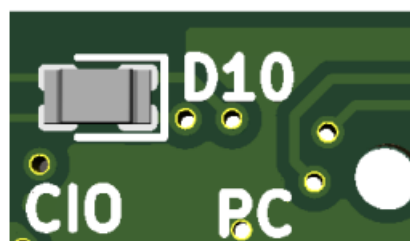

Microcontroller Dual Red/Green Led

Environmental Performance

UbiSwitch is designed with the following features to allow performance in harsh environments.

- Increased board thickness of 2 mm to reduce susceptibility to high frequency vibration standing waves
- Automotive or higher rated components to withstand an extended temperature range of -70°C to +110°C
- X5R or higher rated capacitors for reduced capacitor variability with temperature variation
- Molex PicoClasp positive locking connectors with increased contact area to resist vibration
- Solid state cooling to prevent mechanical failure of moving parts
- 0.8mm pitch stackable connector for increased clearance between signals

Mil-STD-810G Tests and Results

Test Name	Test Description
Low pressure (altitude)	MIL-STD-810G, Method 500.6 - Low Pressure (Altitude), Procedure II - Operation: 1 hour, <10m/s, 30,000 ft
Low pressure (Decompression)	Method 500.6 - Low Pressure (Altitude), Procedure III - Rapid Decompression: 8,000ft to 40,000ft, 15 seconds
High Temperature	Method 501.6 - High Temperature, Procedure II - Operation, Constant Temperature Exposure: 100° C, 2 hours, <3° C/minute, uncontrolled humidity
Low Temperature	Method 502.6 - Low Temperature, Procedure II - Operation: -45° C, 2 hours, <3° C/minute, uncontrolled humidity
Temperature Shock	Method 503.6 - Temperature Shock, Procedure I-A - One-way Shock(s) from Constant Extreme Temperature: -45° C to 100° C, 1 minute 100° C to -45° C, 1 minute
Humidity	Method 507.6 - Humidity, Procedure I - Storage and Transit Cycles: 27° C, 95%, 2 hours
Vibration	Method 514.7 - Vibration, Procedure I - General Vibration, Category 13 - Fixed Wing Propeller Aircraft: Vibration Type: Broadband background with superimposed narrow band spikes Frequency Range: 15Hz - 2000Hz Orientation: In each of 3 mutually orthogonal axes, 1 hour per axis

SOFTWARE INTERFACES

As of May 2024, UbiSwitch can now run configuration software. Revision C models (BB-UBS-C-1) have the firmware preloaded. Revision B (BB-UBS-B-1) models will need the firmware uploaded manually.

DEVICE CONFIGURATION

Unmanaged Switch

To use UbiSwitch in an unmanaged application no configuration is needed. Connect the daughterboard and apply voltage to the voltage input and connect downstream devices.

MECHANICAL DRAWING

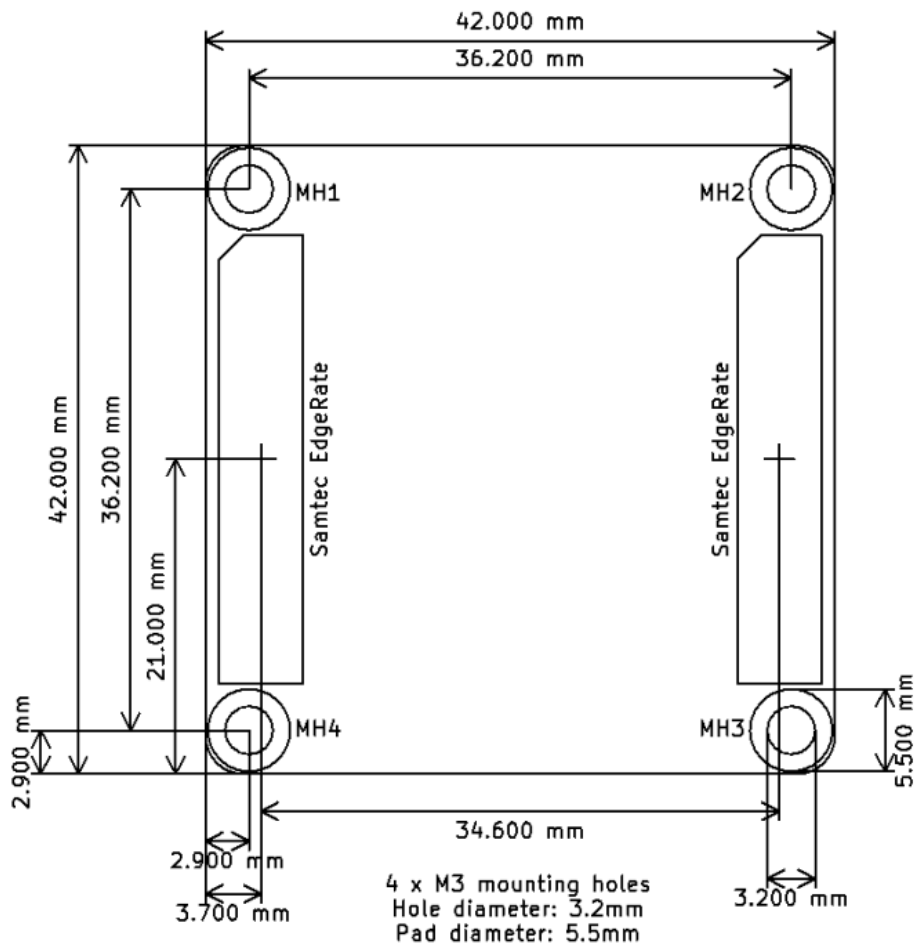

THERMAL CONSIDERATIONS

The main switch chip on UbiSwitch dissipates significant heat under full load conditions, it is recommended to run the device with a thermal heatsink solution.

Thermal Characteristics

Parameter	Condition	Typical Value
θ_{JA} - Thermal resistance, junction to ambient	JEDEC 3 in. x 4.5 in 4-layer PCB with no air flow	22.28 ° C/W
	JEDEC 3 in. x 4.5 in 4-layer PCB with 1m/s air flow	20.13 ° C/W
	JEDEC 3 in. x 4.5 in 4-layer PCB with 2m/s air flow	19.38 ° C/W
	JEDEC 3 in. x 4.5 in 4-layer PCB with 3m/s air flow	18.92 ° C/W
ϕ_{JT} - Thermal characteristic parameter, junction to top-center of package	JEDEC 3 in. x 4.5 in 4-layer PCB with no air flow	0.13 ° C/W
	JEDEC 3 in. x 4.5 in 4-layer PCB with 1m/s air flow	0.21 ° C/W
	JEDEC 3 in. x 4.5 in 4-layer PCB with 2m/s air flow	0.26 ° C/W
	JEDEC 3 in. x 4.5 in 4-layer PCB with 3m/s air flow	0.20 ° C/W
θ_{JC} - Thermal resistance, junction to case	JEDEC with no air flow	5.08 ° C/W
θ_{JB} - Thermal resistance, junction to board	JEDEC with no air flow	12.68 ° C/W

Passive heatsinking

UbiSwitch is supplied with a heatsink that mounts to the top of the main chip.

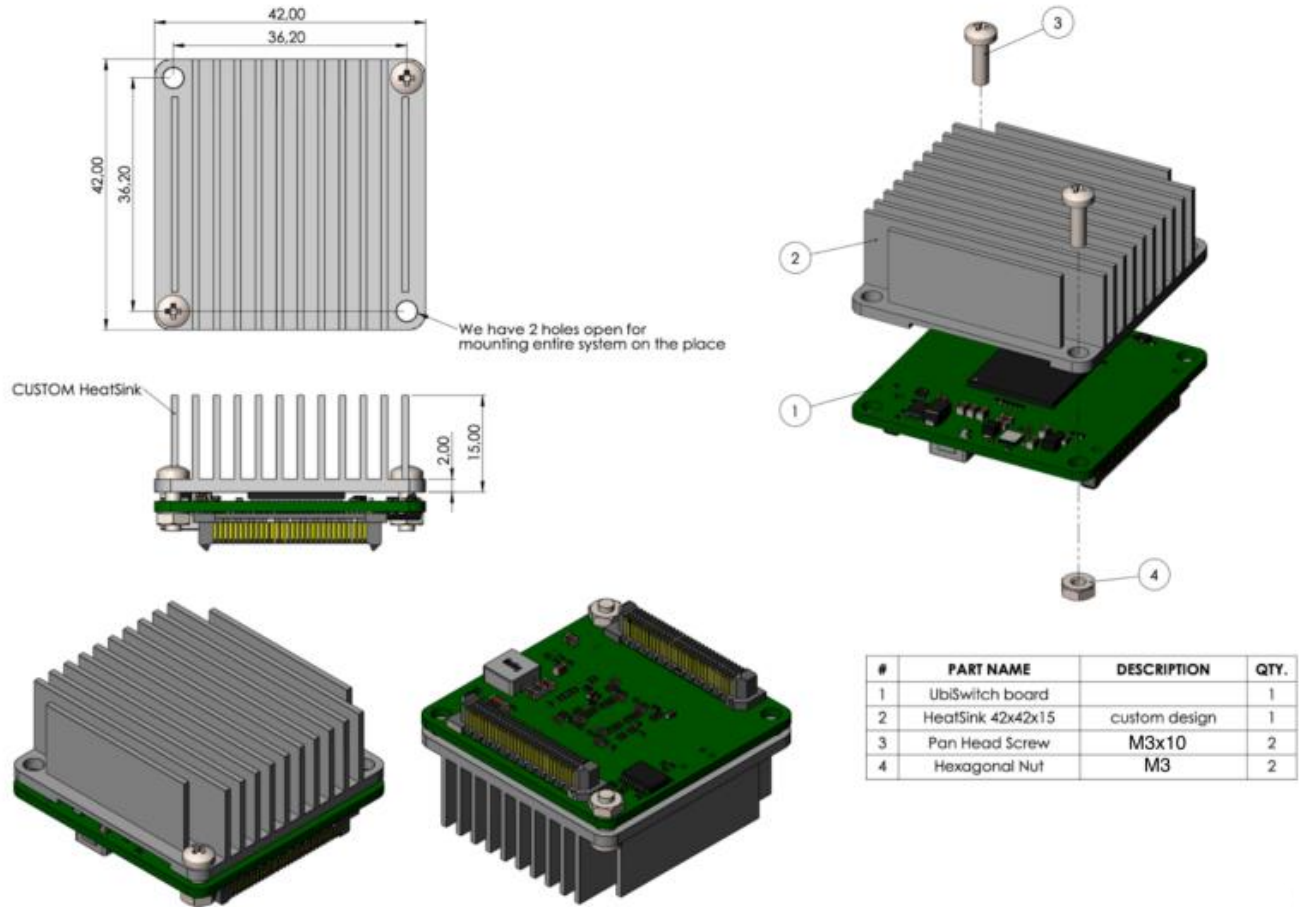

The thermal resistance of the heatsink with zero air flow is around 1.82°C/W . We suggest using thermal paste with around 79W/m-K (for example, TC4-10G) to achieve a paste thermal resistance of 0.675°C/W when used on the $15\text{mm} \times 15\text{mm}$ chip.

Temperature Calculations

No heatsink, 0 m/s airflow:

*not recommended

Power dissipation, PD=4.604 W

$$\theta_{JA} = 22.28^{\circ} \text{ C/W}$$

$$\phi_{JT} = 0.13^{\circ} \text{ C}$$

Ambient temperature = 25 ° C

Case temperature = 4.604 * 22.28 = 102.57 ° C (above ambient)

Junction temperature = (0.13 * 4.604) + 102.57 = 103.16 ° C (above ambient)

Actual temperature of junction at ambient = 128.16 ° C

Included heatsink 0 m/s airflow:

Power dissipation, Pd = 4.604 W

$$\theta_{JC} = 5.08^{\circ} \text{ C/W}$$

θ_{CH} (Case to heatsink) = 0.675 ° C/W (Mainly thermal resistance of thermal paste)

θ_{HA} (heatsink to ambient) = 1.82 ° C/W

$$\phi_{JT} = 0.13^{\circ} \text{ C}$$

Ambient temperature = 25 ° C

Heatsink temperature rise = 4.604 * (5.08 + 0.675 + 1.82) = 34.87 ° C (above ambient)

Estimated junction temperature = ~70° C

ASSEMBLY & MOUNTING INFORMATION

Required Hardware

- UbiSwitch Module
- UbiSwitch Heatsink
- UbiSwitch BaseBoard
- Thermal Paste (TC4-10G recommended)
- 2 x M3 pan head machine screws, 10mm length
- 2 x M3 pan head machine screws, 20mm length
- 4 x M3 hex nuts
- 4 x 2mm nylon washer

Assembling the heatsink

The first step in assembling the UbiSwitch is to mount the heatsink on the UbiSwitch module. The steps below assume use of the included heatsink, steps may vary if using a custom heatsink.

Step 1: Add thermal paste

Add thermal paste to the top of the main chip on the UbiSwitch Module.



Step 2: Identify correct heatsink polarity

Some material is removed on the underside of the heatsink; this is to accommodate the taller circuitry on the UbiSwitch module. It is important to ensure the heatsink is mounted as shown below to ensure that this gap aligns with the taller circuitry on UbiSwitch.

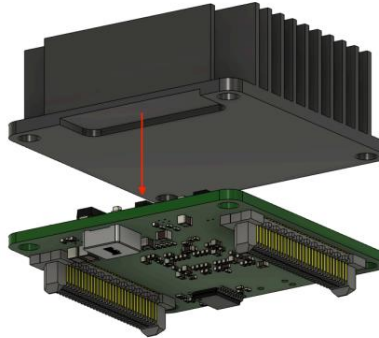

Step 3: Place Washers and screws

Once the correct heatsink alignment is achieved place the two M3 12mm machine screws through two of the holes on the heatsink, and place two washers on these same holes. The image below shows which holes to put the M3 12 mm screws through. Only these holes are used for mounting the heatsink.

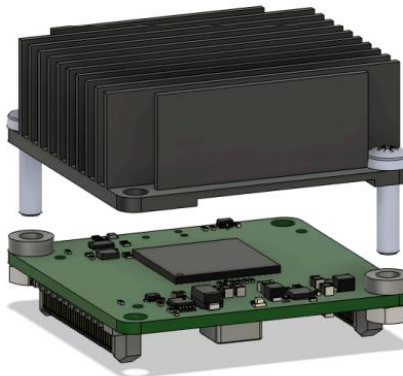

Step 4 add hex nuts to the bottom

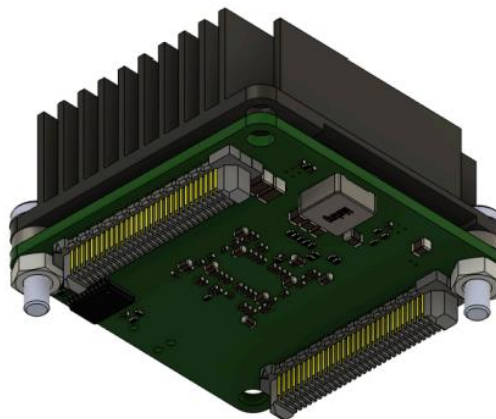

Step 5: Mount the UbiSwitch Module + Heatsink assembly onto the UbiSwitch baseboard

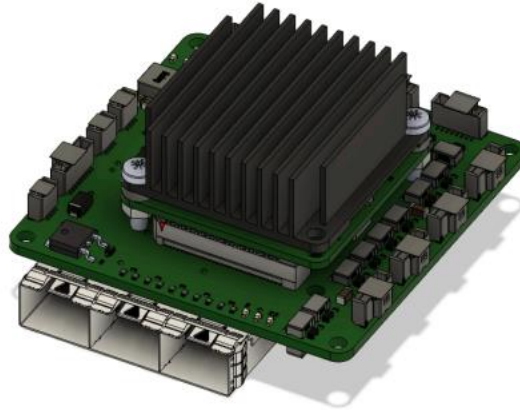

Step 6: add washers and screws to the remaining mount holes

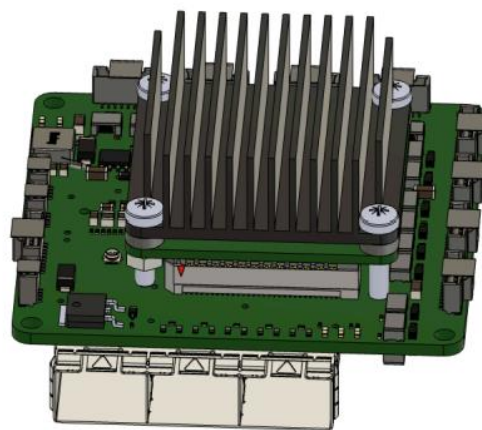

Step 7: Add hex nuts to the two remaining screws to secure the UbiSwitch Module to the UbiSwitch baseboard

These hex nuts fix the UbiSwitch module to the UbiSwitch Baseboard, this is necessary as the stacking header system on the UbiSwitch is not locking. The arrow in the image below shows one of the hex nuts that is close to the onboard transformers; care should be taken not to damage the transformers when tightening this nut.

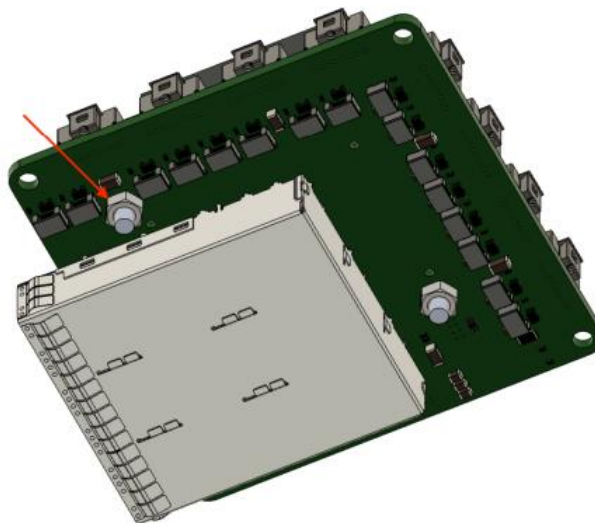

*Revision B of the UbiSwitch Baseboard has integrated threaded spacers eliminating the need for hex nuts to mount the UbiSwitch module

Notice: Specifications are subject to change without notice. Contact your nearest Amphenol Corporation Sales Office for the latest specifications. All statements, information and data given herein are believed to be accurate and reliable but are presented without guarantee, warranty, or responsibility of any kind, expressed or implied. Statements or suggestions concerning possible use of our products are made without representation or warranty that any such use is free of patent infringement and are not recommendations to infringe any patent. The user should assume that all safety measures are indicated or that other measures may not be required. Specifications are typical and may not apply to all connectors.

AMPHENOL is a registered trademark of Amphenol Corporation.

©2023 Amphenol Corporation REV: PRELIMINARY

Amphenol

MILITARY HIGH SPEED

40-60 Delaware Avenue

Sidney, NY 13838

amphenol-aerospace.com | amphenolmao.com