

HIGH DENSITY INTERCONNECTS

HD38999

PDS-208-27



A CONNECTOR WITH AS FEW AS 9 CONTACTS AND AS MANY AS 187.

The HD38999 family of connectors has 30% more contact density than the highest density Mil Spec 38999 connectors of its size. This series of connectors was designed to utilize mil-specified 38999 components with the exception of the contacts and inserts arrangement. Utilizing existing mil-qualified 39029 size 23 contacts and 38999 insert materials, these connectors are essentially a drop-in replacement for the standard 38999 connector.

This connector design benefits users in a couple of different ways. For those users who need to increase the amount of contacts in their application, the HD38999 series allows them to do so without increasing the size of their connector. For users who are looking to decrease the overall size of their system, they can do so by using smaller shell sizes without decreasing the number of contacts.

Amphenol has qualified this series of connectors to the requirements of MIL-DTL-38999. Amphenol also manufactures this high density series in Filter, Hermetic and customized versions to fit our customer's needs. Please contact us if additional information is required.

HD38999
High Density

HIGH DENSITY INTERCONNECTS

INSERT

High Density Shell Sizes (Front of Pin Insert Shown)
(all contacts are size 23)

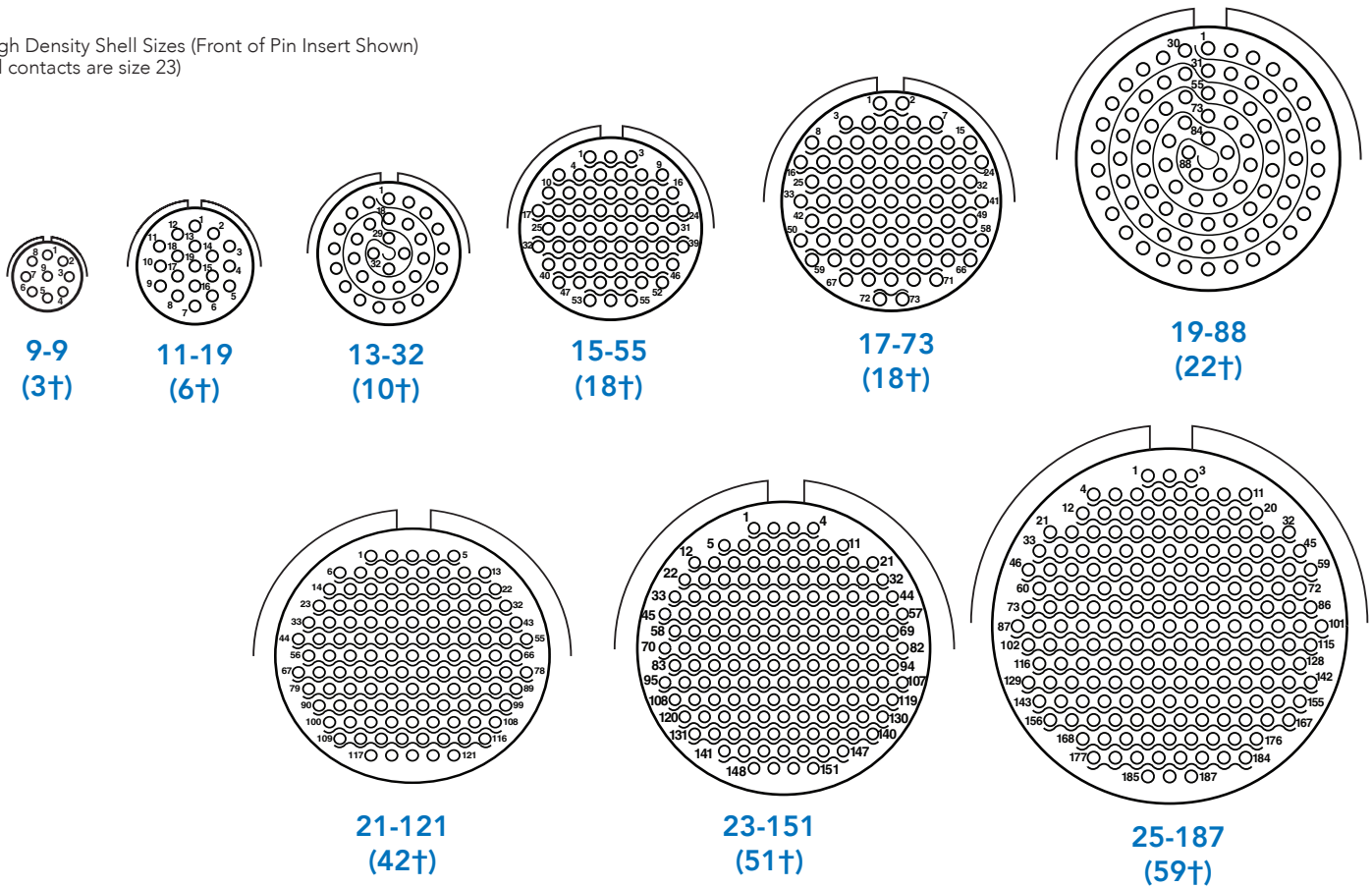

(†Increased number of contacts in HD38999 insert pattern compared to Standard 38999*contact density of same shell size.)

HIGH DENSITY INTERCONNECTS

1. Connector Type	2. Shell Style	3. Service Class	4. Shell Size - Insert Arrangement	5. Contact Type	6. Alternate Positions	7. PCB Optional
TV or PTV (Potted version)	07	RW	23-151	P	B	(P25)

P (prefix for Potted)

1. Connector Type	
TV	Tri-Start Series Connector
TVP	Panel Mounted Receptacle
CTV	Composite Tri-Start Series
CTVP	Panel Mounted Composite

*Add P prefix for potted ex: PTV

4. Shell Size – Insert Arrangement	
Shell Size	Insert Arrangement Number
9-	9
11-	19
13-	32
15-	55
17-	73
19-	88
21-	121
23-	151
25-	187

Shell Sizes are MIL-DTL-38999, Series III.

5. Contact Type	
P	500 Cycle Pin Contacts
S	500 Cycle Socket Contacts
H	1500 Cycle Pin Contacts
J	1500 Cycle Socket Contacts

2. Shell Style	
00	Wall Mount Receptacle
40	Wall Mount Double Flange Receptacle
10	Wall Mount (Clinch Nuts)
80	Wall Mount with Integral Backshell
02	Box Mount Receptacle
12	Box Mount (Clinch Nuts)
01	Line Receptacle
07	Jam Nut Receptacle
47	Jam Nut Double Flange Receptacle
87	Jam Nut with Integral Backshell
97	Reduced Flange Jam Nut Receptacle
98	Reduced Flange Jam Nut with Standoffs
06	Straight Plug
96	Straight Plug with Integral Backshell (not available in composite)
76	Plug with Integral Strain Relief

3. Service Class (ALL 175°C)		
RW	Corrosion resistant olive drab cadmium plated aluminum, 500 hour extended salt spray	
DT	Durmalon plated, alternative to cadmium. Corrosion resistant, 500 hour extended salt spray	
DZ	Black Zinc-Nickel alternative to cadmium. 500 hour salt spray, conductive	
DW	Corrosion resistant olive drab cadmium plated aluminum, 1,000 hour extended salt spray	
RB	Marine Bronze - 500 hour salt spray	
RF	Electroless nickel plated aluminum, 48 hour salt spray	
RK	Corrosion resistant stainless steel, firewall capability, plus 500 hour salt spray resistance	
RKN	Corrosion resistant stainless steel, Nonfirewall capability, plus 500 hour salt spray resistance	
RL	Corrosion resistant steel, electro deposited nickel, 500 hour salt spray, non firewall	
RS	(Non-hermetic connectors), Nickel plated, corrosion resistant steel, firewall capability, 500 hour salt spray	
DB	Black Electroless Nickel, 100 hour salt spray	

1. Connector Type	2. Shell Style	3. Service Class	4. Shell Size - Insert Arrangement	5. Contact Type	6. Alternate Positions	7. PCB Options
TV or PTV (Potted version)	06	RW	23-151	P	B	(P25)

6. ALTERNATE POSITION					
Shell size	Key & keyway arrangement identification letter	AR° or AP° BSC	BR° or BP° BSC	CR° or CP° BSC	DR° or DP° BSC
9	N	105	140	215	265
	A	102	132	248	320
	B	80	118	230	312
	C	35	140	205	275
	D	64	155	234	304
11, 13, and 15	N	95	141	208	236
	A	113	156	182	292
	B	90	145	195	252
	C	53	156	220	255
	D	119	146	176	298
17 and 19	N	80	142	196	293
	A	135	170	200	310
	B	49	169	200	244
	C	66	140	200	257
	D	62	145	180	280
21, 23 and 25	N	80	142	196	293
	A	135	170	200	310
	B	49	169	200	244
	C	66	140	200	257
	D	62	145	180	280
	E	79	153	197	272

A, B, C, D, E or blank for normal.

RECEPTACLE (front face shown)

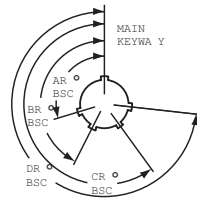

PLUG (front face shown)

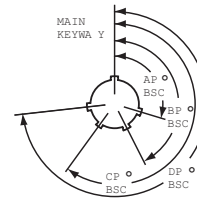

A plug with a given rotation letter will mate with a receptacle with the same rotation letter. The angles for a given connector are the same whether it contains pins or sockets. Inserts are not rotated in conjunction with the master key/keyway.

7. PCB Contact Options				
Pin Contacts	Pin Contacts with Alignment Disc*	Socket Contacts	Socket Contacts with Alignment Disc	PCB tail stickout +/- .040 inch
P1	P1AD	S1	S1AD	.100" nominal
P15	P15AD	S15	S15AD	.150" nominal
P2	P2AD	S2	S2AD	.200" nominal
P25	P25AD	S25	S25AD	.250" nominal
P3	P3AD	S3	S3AD	.300" nominal
P35	P35AD	S35	S35AD	.350" nominal

Pre-Tin Options

Add "T" to end of suffix for Pre-tinned PC tails
Ex: (P15T), (S25ADT)

CONTACTS & TOOLS

CONTACT PART NUMBERS*:

Size 23 Sockets 10-597330-735 (M39029/17-172)
 Size 23 Pins 10-597331-735 (M39029/18-177)
 Sealing Plugs 10-405996-222 (MS27488-22-2)

*Amphenol may use other contacts not listed above

CRIMP BARREL DIA.: **CRIMP BARREL**
 (Inches) .034-.036 **DEPTH:**
 (Inches) .151-.155

TOOLS:

Crimp Tool: Daniels M22520/2-01
 Positioner: Daniels M22520/2-16 Socket
 Daniels M22520/2-13 Pin
 Insertion Tool: Daniels DAK225-22
 Removal Tool: Daniels DRK225-22
 Insertion/Removal Tool: M81969/16-04 (Plastic)

Note: Wire insulation diameter greater than 0.045 is too large for the extraction tool to work properly. Connector damage is possible.

TECHNICAL DATA

HD38999 series was designed to meet and/or exceed the specifications of MIL-DTL-38999. The connector series has been tested to all the requirements of 38999 with the use of AS39029 size 23 contacts. Test reports are available upon request. The following is a summary of some of the performance requirements.

EMI SHIELDING EFFECTIVENESS:

Solid metal to metal coupling, EMI grounding fingers and conductive finishes have proven to be the ultimate in EMI/EMP shielding effectiveness. The following chart illustrated shielding effectiveness data which is typical in HD38999 connectors.

ELECTRICAL:

22 AWG: 5.0 AMPS
 24 AWG: 3.0 AMPS
 26 AWG: 2.0 AMPS
 28 AWG: 1.5 AMPS

Insulation Resistance: 5000 megohms min.@500 VDC 25C

Dielectric Withstanding Voltage: 1000 VRMS@sea level

MECHANICAL:

Metallic Shells:

Material: Aluminum alloy, Stainless Steel
 Protection: Electroless Nickel, O.D. Cadmium, Durmalon (Nickel PTFE), Zinc Nickel

Composite Shells:

Material: Thermoplastic Protection:
 Electroless Nickel, O.D. Cadmium, Durmalon (Nickel PTFE), Zinc Nickel

Contacts: Material: Copper Alloy
 Protection: Gold over Nickel

Insert Retention to Shell: 100 psi in axial load

Durability: 500 full mating and unmating cycles

Vibration: 60G sine per MIL-DTL-38999L Para 4.5.23.2.1
 5G2 Random per EIA-364-28E, Test condition A
 1G2 Random per EIA-364-28E, Test condition I

Shock: Per EIA-364-27B, 300g

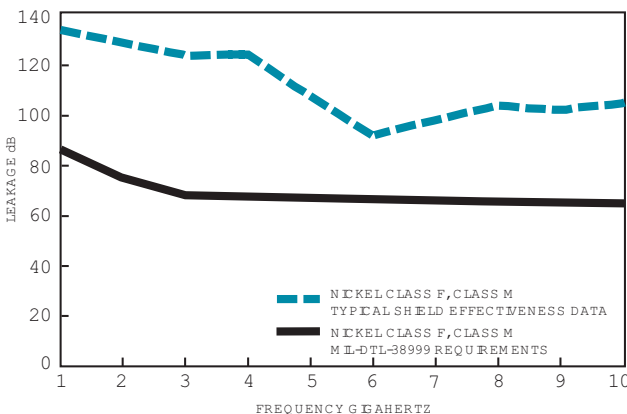
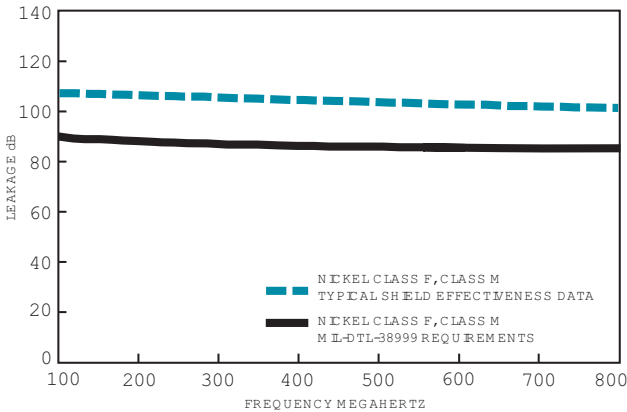

TECHNICAL DATA

Environmental:

Operating Temperature: -65°C to +175°C

Salt Spray:

Metallized: Electroless Nickel: 48 hours
 Anodic Coating, O. D. Cadmium, Durmalon,
 Zinc Nickel: 500 hours

Salt Spray Composite: Electroless Nickel: 1000 hours
 O. D. Cadmium, Durmalon, Zinc Nickel: 500 hours

WALL MOUNTING RECEPTACLE

TVP00() - CRIMP, METAL
 CTVP00() - CRIMP, COMPOSITE

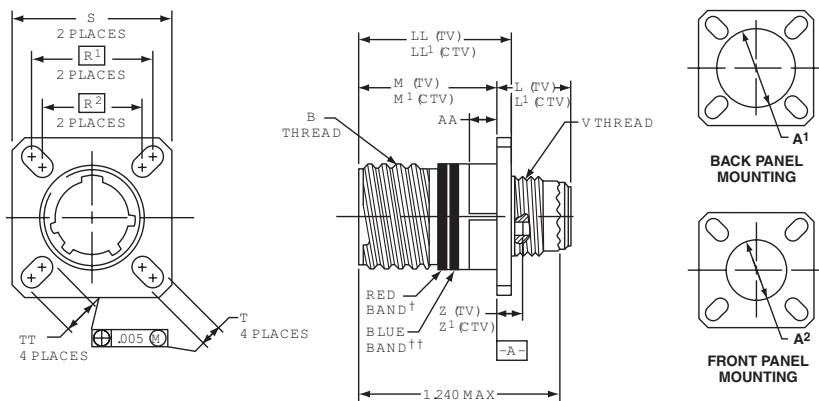

See how to build a part number on pages 2

† Red band indicates fully mated

†† Blue band indicates rear release contact retention system.

Inches

Shell Size	MS Shell Size Code	B Thread Class 2A 0.1P-0.3L-TS (Plated)	L Max. (TV)	L1 Max. (CTV)	M +.000 - .005 (TV)	M1 +.000 - .005 (CTV)	R1	R2	S Max.	T ±.008	Z Max. (TV)	Z1 Max. (CTV)	A1 Back Panel Mount	A2 Front Panel Mount	AA Max. Panel Thickness	LL +.006 - .000 (TV)	LL1 ±.005 (CTV)	TT ±.008
9	A	.6250	.469	.520	.820	.773	.719	.594	.948	.128	.153	.198	.650	.510	.234	.905	.908	.216
11	B	.7500	.469	.520	.820	.773	.812	.719	1.043	.128	.153	.198	.800	.620	.234	.905	.908	.194
13	C	.8750	.469	.520	.820	.773	.906	.812	1.137	.128	.153	.198	.910	.740	.234	.905	.908	.194
15	D	1.0000	.469	.520	.820	.773	.969	.906	1.232	.128	.153	.198	1.040	.900	.234	.905	.908	.173
17	E	1.1875	.469	.520	.820	.773	1.062	.969	1.323	.128	.153	.198	1.210	1.010	.234	.905	.908	.194
19	F	1.2500	.469	.520	.820	.773	1.156	1.062	1.449	.128	.153	.198	1.280	1.130	.234	.905	.908	.194
21	G	1.3750	.500	.552	.790	.741	1.250	1.156	1.575	.128	.183	.228	1.410	1.250	.204	.905	.904	.194
23	H	1.5000	.500	.552	.790	.741	1.375	1.250	1.701	.154	.183	.228	1.530	1.360	.204	.905	.904	.242
25	J	1.6250	.500	.552	.790	.741	1.500	1.375	1.823	.154	.183	.228	1.660	1.470	.204	.905	.904	.242

BOX MOUNT RECEPTACLE

TVP02() - CRIMP, METAL
 CTVP02() - CRIMP, COMPOSITE

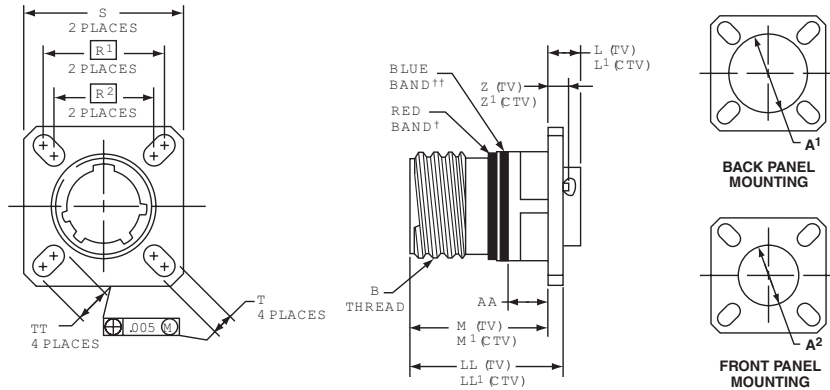

See how to build a part number on pages 2 & 3

† Red band indicates fully mated

†† Blue band indicates rear release contact retention system.

**Consult Amphenol Aerospace for availability for box mount receptacles.

Shell Size	MS Shell Size Code	B Thread Class 2A 0.1P-0.3L-TS (Plated)	L Max. (TV)	L1 Max. (CTV)	M +.000 - .005 (TV)	M1 +.000 - .005 (CTV)	R1	R2	S Max.	T ±.008	Z. Max. (TV)	Z1 Max. (CTV)	A1 Back Panel Mount	A2 Front Panel Mount	AA Max. Panel Thickness	LL +.006 - .000 (TV)	LL1 ±.005 (CTV)	TT ±.008
9	A	.6250	.205	.250	.820	.773	.719	.594	.948	.128	.153	.198	.650	.510	.234	.905	.908	.216
11	B	.7500	.205	.250	.820	.773	.812	.719	1.043	.128	.153	.198	.800	.620	.234	.905	.908	.194
13	C	.8750	.205	.250	.820	.773	.906	.812	1.137	.128	.153	.198	.910	.740	.234	.905	.908	.194
15	D	1.0000	.205	.250	.820	.773	.969	.906	1.232	.128	.153	.198	1.040	.900	.234	.905	.908	.173
17	E	1.1875	.205	.250	.820	.773	1.062	.969	1.323	.128	.153	.198	1.210	1.010	.234	.905	.908	.194
19	F	1.2500	.205	.250	.820	.773	1.156	1.062	1.449	.128	.153	.198	1.280	1.130	.234	.905	.908	.194
21	G	1.3750	.235	.280	.790	.741	1.250	1.156	1.575	.128	.183	.228	1.410	1.250	.204	.905	.904	.194
23	H	1.5000	.235	.280	.790	.741	1.375	1.250	1.701	.154	.183	.228	1.530	1.360	.204	.905	.904	.242
25	J	1.6250	.235	.280	.790	.741	1.500	1.375	1.823	.154	.183	.228	1.660	1.470	.204	.905	.904	.242

JAM NUT RECEPTACLE

TV07() - CRIMP, METAL
CTV07() - CRIMP, COMPOSITE

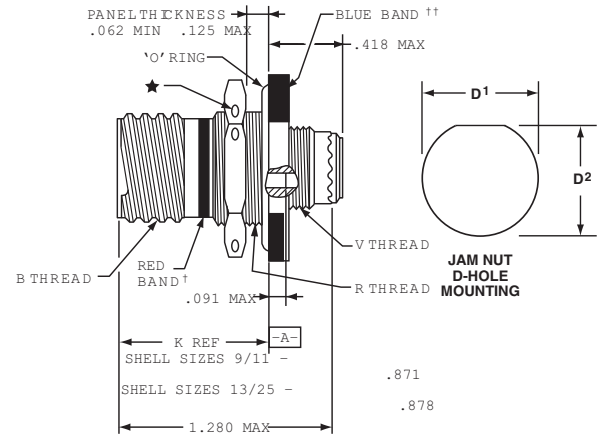
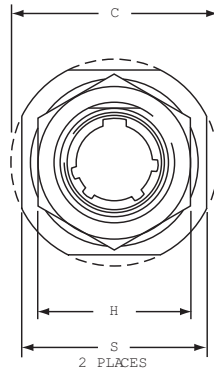

See how to build a part number on pages 2

† Red band indicates fully mated

†† Blue band indicates rear release contact retention system.

H .059 dia. min., 3 lockwire holes. Formed lockwire hole design (6 holes) is optional

Shell Size	MS Shell Size Code	B Thread Class 2A 0.1P-0.3L-TS (Plated)	C Max.	D ¹ +.010 -.000	D ² +.000 -.010	H Hex +.017 -.016	S ±.010	V Thread Metric	R Thread (Plated) 9-7543
9	A	.6250	1.199	.693	.657	.875	1.062	M12X1-6g	M17X1-6g
11	B	.7500	1.386	.825	.770	1.000	1.250	M15X1-6g	M20X1-6g
13	C	.8750	1.511	1.010	.955	1.188	1.375	M18X1-6g	M25X1-6g
15	D	1.0000	1.636	1.135	1.085	1.312	1.500	M22X1-6g	M28X1-6g
17	E	1.1875	1.761	1.260	1.210	1.438	1.625	M25X1-6g	M32X1-6g
19	F	1.2500	1.949	1.385	1.335	1.562	1.812	M28X1-6g	M35X1-6g
21	G	1.3750	2.073	1.510	1.460	1.688	1.938	M31X1-6g	M38X1-6g
23	H	1.5000	2.199	1.635	1.585	1.812	2.062	M34X1-6g	M41X1-6g
25	J	1.6250	2.323	1.760	1.710	2.000	2.188	M37X1-6g	M44X1-6g

REDUCED FLANGE JAM NUT RECEPTACLE

TV97() - CRIMP, METAL

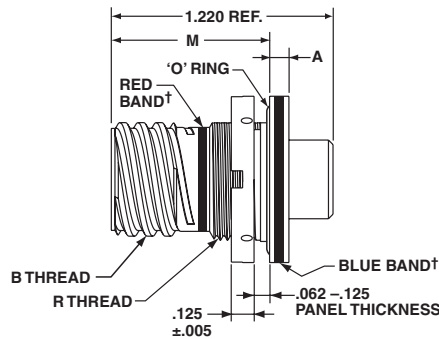
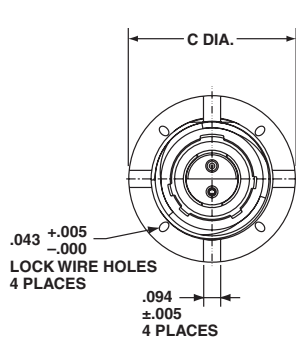

Shell Size	MS Shell Size Code	B Thread Class 2A 0.1P-0.3L-TS (Plated)	A +.010 -.005	C Dia. Max.	D ¹ +.010 -.000	D ² +.000 -.010	M	R Thread (Plated) 9-7543
9	A	.6250	.104	.915	.693	.657	.871	M17X1-6g
11	B	.7500	.104	1.042	.825	.770	.871	M20X1-6g
13	C	.8750	.104	1.240	1.010	.955	.878	M25X1-6g
15	D	1.0000	.104	1.357	1.135	1.085	.878	M28X1-6g
17	E	1.1875	.104	1.630	1.260	1.210	.878	M32X1-6g
19	F	1.2500	.135	1.816	1.385	1.335	.878	M35X1-6g
21	G	1.3750	.135	1.942	1.510	1.460	.878	M38X1-6g
23	H	1.5000	.135	2.067	1.635	1.585	.878	M41X1-6g
25	J	1.6250	.135	2.190	1.760	1.710	.878	M44X1-6g

JAM NUT DOUBLE FLANGE RECEPTACLE

(PRINTED CIRCUIT BOARD MOUNT)

TV47() - CRIMP, METAL

CTV47() - CRIMP, COMPOSITE

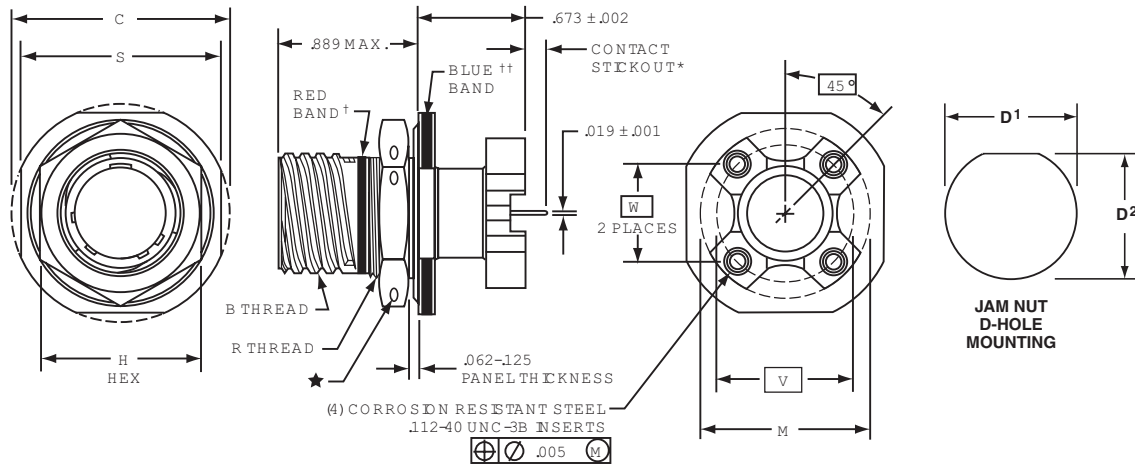

See how to build a part number on pages 2

* Contact stickout dimension: see Step 7 of how to order on page 2.

† Red band indicates fully mated

†† Blue band indicates rear release contact retention system.

H .059 dia. min., 3 lockwire holes. Formed lockwire hole design (6 holes) is optional

Shell Size	MS Shell Size Code	B Thread Class 2A 0.1P-0.3L-TS (Plated)	C ±.005 (Jam Nut Flange Dia.)	D ¹ +.010 -.000	D ² +.000 -.010	H Hex +.017 -.016	M Dia. ±.005	R Thread Metric (Plated)	S +.011 -.010	PCB Mounting Dimensions	
										V Dia. (TV) TP	W (CTV) TP
9	A	.6250	1.188	.700	.670	.875	1.016	M17X1-6g0.100R	1.062	.753	.532
11	B	.7500	1.375	.825	.770	1.000	1.148	M20X1-6g0.100R	1.250	.850	.601
13	C	.8750	1.500	1.010	.955	1.188	1.250	M25X1-6g0.100R	1.375	.994	.703
15	D	1.0000	1.625	1.135	1.085	1.312	1.375	M28X1-6g0.100R	1.500	1.119	.791
17	E	1.1875	1.750	1.260	1.210	1.438	1.500	M32X1-6g0.100R	1.625	1.237	.875
19	F	1.2500	1.937	1.385	1.335	1.562	1.625	M35X1-6g0.100R	1.812	1.379	.975
21	G	1.3750	2.062	1.510	1.460	1.688	1.750	M38X1-6g0.100R	1.937	1.489	1.053
23	H	1.5000	2.188	1.635	1.585	1.812	1.875	M41X1-6g0.100R	2.062	1.644	1.145
25	J	1.6250	2.312	1.760	1.710	2.000	2.000	M44X1-6g0.100R	2.188	1.744	1.233

STRAIGHT PLUG

TV06() - CRIMP, METAL
CTV06() - CRIMP, COMPOSITE

† Blue band indicates rear release contact retention system

Shell Size	MS Shell Size Code	B Thread 0.1P-0.3L-TS-2B (Plated)	Q Dia. Max.
9	A	.6250	.858
11	B	.7500	.984
13	C	.8750	1.157
15	D	1.0000	1.280
17	E	1.1875	1.406
19	F	1.2500	1.516
21	G	1.3750	1.642
23	H	1.5000	1.768
25	J	1.6250	1.890

METAL

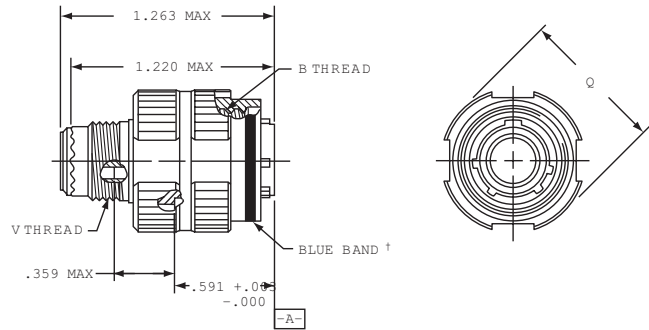

COMPOSITE

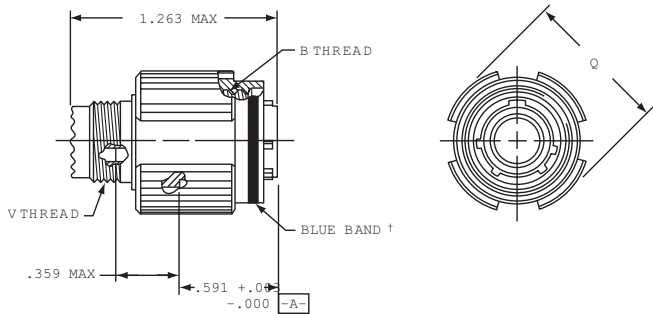

STRAIGHT PLUG WITH INTEGRAL BACKSHELL

TV96() (TV TYPE) - CRIMP, METAL

This MIL-DTL-38999 Series III style connector features an integral backshell design that eliminates the need for costly backshell accessories. The backshell feature is incorporated into the rear of the connector shell, allowing the user to attach the shield of their cable directly to the connector. This provides superior EMI shielding and ease for overmold applications. The straight plug with integral backshell is available in aluminum shells with OD Cad or Electroless Nickel plating.



See how to build a part number on pages 2

† Blue band indicates rear release contact retention system.

Shell Size	MS Shell Size Code	A Max.	B +.005 -.000	C +.003 -.002
9	A	.859	.416	.472
11	B	.969	.524	.580
13	C	1.141	.652	.708
15	D	1.266	.810	.866
17	E	1.391	.928	.984
19	F	1.500	1.046	1.102
21	G	1.625	1.164	1.220
23	H	1.750	1.282	1.338
25	J	1.875	1.400	1.456

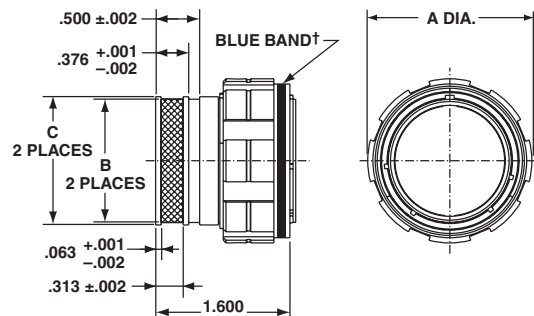

NEW CUSTOM DESIGNED HD38999 CONNECTORS - PROVIDE MORE INTERCONNECT SOLUTIONS

ALIGNMENT DISKS

Alignment disks keep contacts aligned for easier insertion into circuit boards. These are typically ordered with the connector - see step 7 of How to Order on page 2.



FILTERED HD38999 CONNECTORS - FOR EMI/EMP PROTECTION

High density patterns are available in filter 38999 connectors - consult Amphenol Aerospace for ordering.

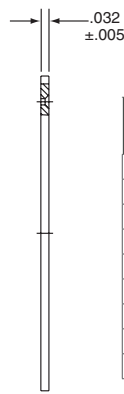
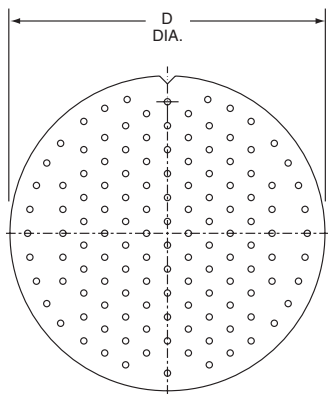
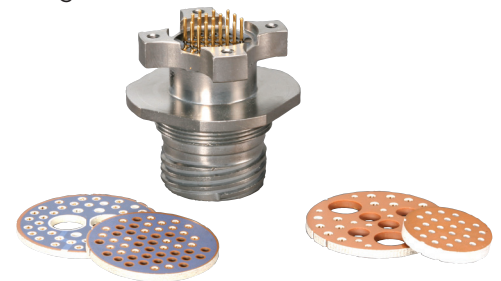

Shell Size	D Dia. ±.010
9	.234
11	.350
13	.500
15	.725
17	.750
19	.850
21	.953
23	1.147
25	1.250

HD38999 FOR GIGABIT ETHERNET APPLICATIONS

The HD38999 is available for high speed (Gigabit Ethernet) data transmission in the size 9-9 insert pattern. Data transmission performance of this connector insert: 10 Base T, 100 Base TX, and 1000 Base T networks using Cat 5e per TIA/EIA568B and Class D per ISO/IEC 11801. (Test report available - consult Amphenol Aerospace for more information)

SIGNAL-GROUND PIN CONFIGURATION WIRING RECOMMENDATIONS

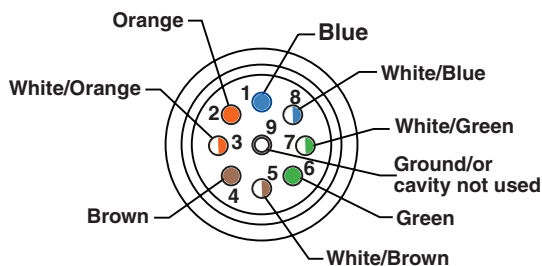

VIEW REAR OF CONNECTOR

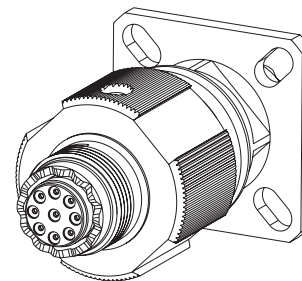

HD38999 CONNECTOR WITH 9-9 INSERT PATTERN (REAR VIEW)

Notice: Specifications are subject to change without notice. Contact your nearest Amphenol Corporation Sales Office for the latest specifications. All statements, information and data given herein are believed to be accurate and reliable but are presented without guarantee, warranty, or responsibility of any kind, expressed or implied. Statements or suggestions concerning possible use of our products are made without representation or warranty that any such use is free of patent infringement and are not recommendations to infringe any patent. The user should assume that all safety measures are indicated or that other measures may not be required. Specifications are typical and may not apply to all connectors.

AMPHENOL is a registered trademark of Amphenol Corporation. ©2020 Amphenol Corporation REV:3/30/2020