

M4067 Series

AC/DC POWER SUPPLY



DESCRIPTION:

The M4067 is a military grade 6U VPX, 115VAC 3 phase, AC-DC PSU card that provides six outputs per VITA 62 and is rated at 700W output power. Features include: conduction cooling, 1” pitch, internal EMI filters, I2C system management, active power-factor correction. AC input range is 85-265Vac 50-800Hz per MIL-STD-704 and DO-160. Designed to meet MIL-STD-810 and MIL-STD-461.

FEATURES

- VITA 62/6U
- High efficiency
- Input /Output isolation
- Remote sense
- EMI filters included
- Fixed switching frequency
- 2C/IPMI communication
- External Inhibit & Enable
- Parallel configuration
- Indefinite short circuit protection with auto-recovery
- Over-voltage shutdown with auto-recovery
- Over temperature shutdown with auto recovery

HOW TO ORDER

Part Number	CF-02EM4067	AC/DC POWER SUPPLY
-------------	--------------------	--------------------

PRODUCT SPECIFICATIONS:

Electrical Specifications			
AC Input	115VAC \pm 10% 400Hz Three-Phase		
	Ride-through normal transient IAW MIL-STD-704B-F		
Ripple and Noise	Less than 50mVp-p, typical (max. 1%), measured across 0.1 μ F and 10 μ F on Load		
System Management	I2C/IPMI protocol available voltages, currents and temperature for all voltages (GAx, SCL, SDA)		
DC Outputs (standard version)	P01*	12V/35A	Sense
	P02*	12V/35A	Sense
	P03	5V/12V/40A	Sense
	3.3V_Aux	3.3V/15A	Sense
	+12V_Aux	+12V/1A	
	-12V_Aux	-12V/1A	
	Total power output: 1200W		
Current Sharing	Optional for VS# Outputs ACS or PCS		
Load Transient Overshoot and undershoot	Output dynamic response up to 5% at step load of 60%-90%. Output return to steady stated within 300-500 μ Sec		
Power Factor	voltages, currents and \geq 0.87 Full load		
Isolation	500VDC	Input to Output	
	500VDC	Input to Case	
	500VDC	Output to Case	
EMC	Designed to meet MIL-STD-461F CE102, CS101, CS114, CS115& CS116. ¹		
Efficiency	Typical 89% (Nominal line nominal load, room temperature)		
*P01 and P02 outputs can be connected in parallel to achieve a single 12V/70A output			

PROTECTIONS		
Input	Inrush Current Limiter:	peak value of 5 x IIN for inrush currents lasting longer than 100µs.
	Under Voltage Lock-Out	Unit shuts down when input voltage is below 70Vrms ± 5Vrms.
	Catastrophic Failure Protection	Fuses are available to protect from catastrophic failure. The fuses are rated not to engage due to any normal type operation.
Output	Active or Passive Over-Voltage Protection	Set to engage at 110%-130% of nominal voltage.
	Overload / Short-Circuit Protection	Continuous Hiccup protection (110-130%) for VS#. Aux Typical: 3.3Vaux / 20A 12Vaux. 1.5A-2A -12Vaux. 2.5A-3A
General	Over-Temperature Protection:	Shutdown at temperature of +100°C ± 5°C. Automatic recovery when temperature drops below +90°C ± 5°C. Measured at Unit edge.

Environmental Designed to meet MIL-STD-810G and VITA 47		
Temperature	Operating:	-55°C to +85°C (at plug-in card edge, IAW VITA 62 CC4)
	Storage:	-55°C to +125°C
Humidity	810G Method 507.5 & VITA 47 Para. 4.6 Up to RH 95%	
Reliability	> 314,000 hours, calculated per MIL-STD-217F Notice 2 at +65°C at wedge lock edge, Ground Fixed	
Altitude	810G Method 500.5, Procedure II (Operational) & VITA 47 para. 4.7 60,000 ft.	
Vibration	810G Method 514.6 Procedure I Figure 514.5C-17. General minimum integrity exposure. 1 hour per axis & VITA 47 Vibration Class V2 5- 2000Hz, 0.04g ² /Hz	
Salt Fog	Method 509.5	
Shock	810G Method 516.6 Procedure I & VITA 47 Shock Class OS1 Saw-tooth, 20g peak, 11ms.	
Environmental Stress Screening (ESS) Including random vibration and thermal cycles is also available. Please consult factory for details.		

FUNCTIONS AND SIGNALS (ACCORDING TO VITA 62.0)

Signal Name	Type	Description
FAIL*	Output	Indicates to other modules in the system that a failure has occurred in one of the outputs. Please refer to Figure 2 ¹
SYSRESET*	Output	Indicates to other modules in the system that all outputs are within their working level. Please refer to Figure 2 ¹
INHIBIT*	Input	Controls power supply outputs. This signal in conjunction with INHIBIT controls the outputs. Please refer to Table 1 and Figure 1 ¹
ENABLE*	Input	Controls power supply outputs. This signal in conjunction with INHIBIT controls the outputs. Please refer to Table 1 and Figure 1 ¹
GA0÷4*, GAP**	Input	Used for geographical addressing. GA2 is the most significant bit and GA0 is the least significant bit. ¹
SCL, SDA	Bidirectional	I2C bus Clock and Data respectively. Through this bus the voltage and temperature readouts can be shared. ¹
REF_CLK	Input	The REF_CLK signal is used to allow the power supply frequency to sync with the system frequency. ¹
VOUT SENSE	Input	The SENSE is used to achieve accurate load regulations at load terminals (this is done by connecting the pins directly to the load's terminals).
Alert Bit	Output	Indicates to other modules in the system about Input Voltage loss. Please refer to Figure 2 ¹
Active Current Share	Bidirectional	Support Active current share between Outputs. See Current Share para. ^{1 2 3}
PO#_SHARE	Bidirectional	Support Passive current share between Outputs ¹

Notes:

1. Signal referenced to SIGNAL RTN.
2. When not used leave open
- 3 In Passive or Non-Current share Current Share configuration, this pin is Internally Disconnected.

Table 1 – Inhibit and Enable Functionality

INHIBIT*	Low	Low	High	High
ENABLE*	Low	High	Low	High
VS1, VS2, VS3, ±12VAux	OFF	OFF	ON	OFF
3.3V_AUX	ON	OFF	ON	OFF

Figure 1 – Inhibit and Enable Input stage

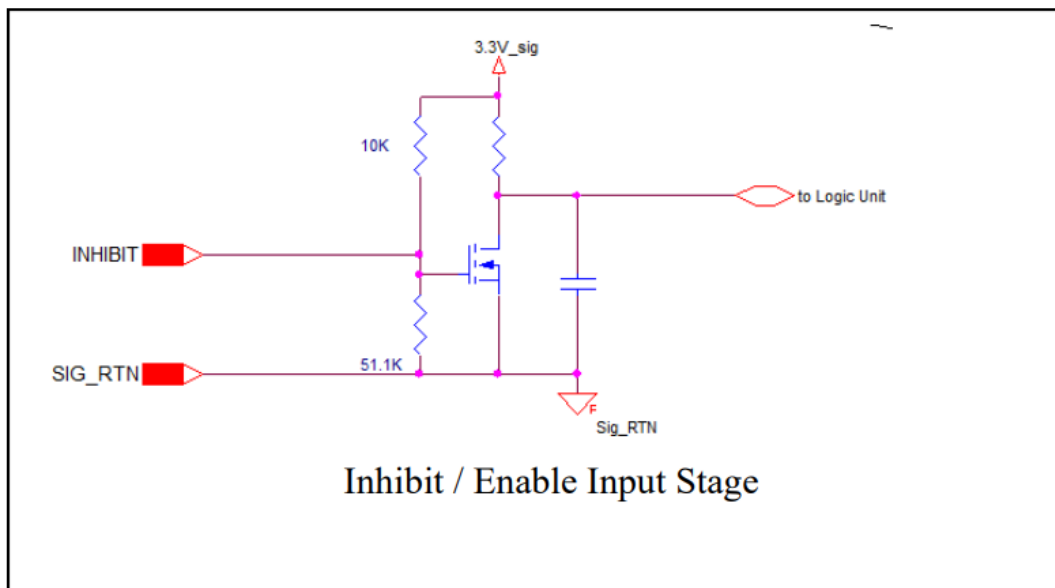
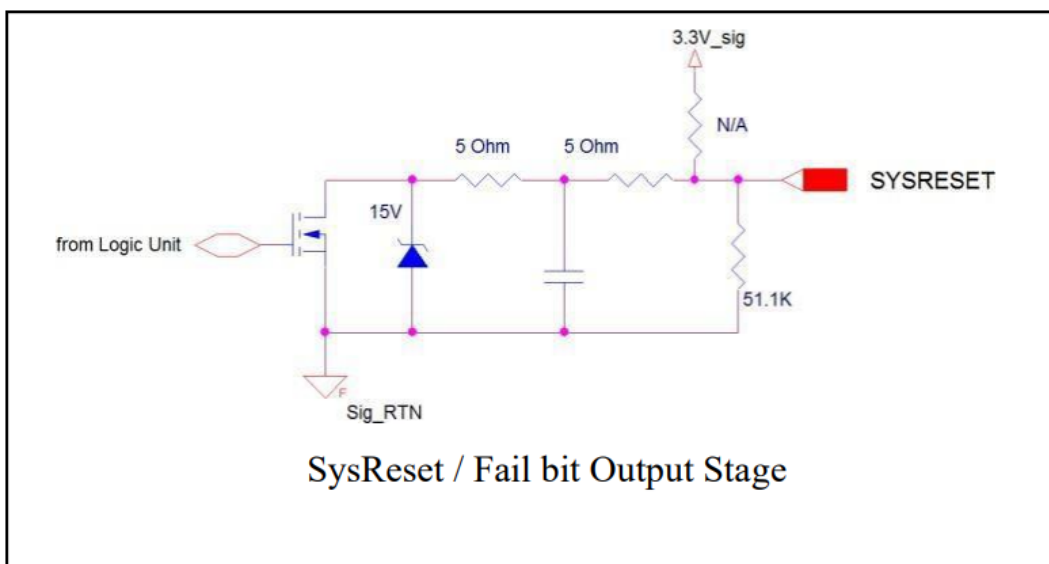

Figure 2 – SysRst and Fail Bit Output Stage



DETAILED INFORMATION

1. Input Voltage Operation.

The M4067 steady state operation is per Mil-STD-704. Unit will work thorough all Normal Transients per Mil-STD-704 B-F, protected to all other transients and interrupts.

2. Outputs Voltage Regulation

The M4067 contains accurate internal sense lines to keep output voltage at less than 3% regulation for all

Line / Load and temperature range (see Table 2).

Output	12V/25A	5V/30A	3.3V/20A	3.3VAux/5A	12VAux/1A	(-)12VAux/1A
Voltage Range	11.85 – 12.15	4.9 – 5.1	3.28 – 3.42	3.2 – 3.4	11.65 – 12.15	(-)11.85 – (-)12.15

Table 2: Outputs voltage regulation. Temperature -55°C – 85°C

2.1 Sense Lines

Sense Lines are provided for VS1, VS2 and VS3 output to compensate line voltage drop.

Sense Lines proper connection is shown in Figure 3.

Each VS# output has its own Sense Lines, additional common Sense RTN Line is provided for all VSx Outputs (VITA 62 Standard).

Contact Factory for Sense configuration different than the VITA 62 standard

Note: when two or three VS# have the same configuration (e.g. VS1 and VS2 are both 12V), sense lines of those outputs will be shorted internally.

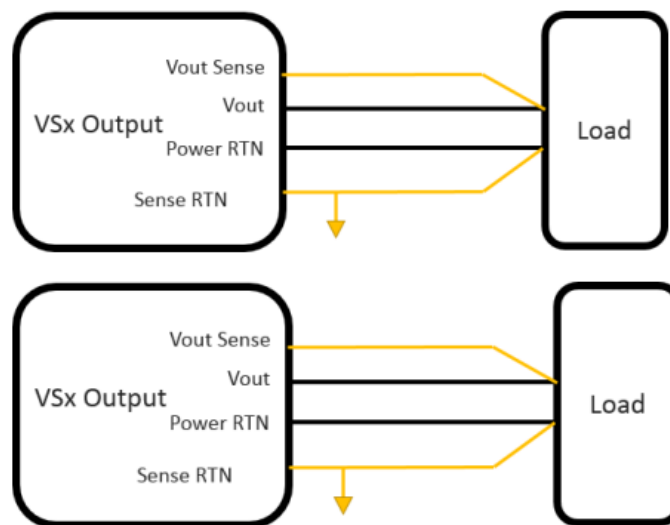

Figure 3: M4067 Sense line connection

3. Current Share (C.S)

Two VS# outputs can be configured as current share to double the output current. It is also possible to support parallel configuration of two units. VS1, VS2 and VS3 will current share with about 5-10% load balance. All Aux Outputs can be paralleled, but would not support current sharing. The unit can support two methods of current sharing:

3.1 Passive Current Sharing (P.C.S)

Current sharing is done in open loop, output voltage drops as a function of output load. For Output to be P.C.S, PO#_SHARE Pins should be connected between two units.

3.2 Active current sharing (A.C.S)

Current sharing is done in a closed loop. All paralleled outputs are compared and feedback is used to balance their load current. The result is a more stable, less sensitive output voltage without voltage drop.

3.3 Current share connection between two Units.

3.3.1 Passive Current Share:

For a required output to P.C.S please connect the following Pins between the two units

- PO#_Sense & PO#_Sense_RTN
- PO#_SHARE

Note: if two outputs of a unit are configured as paralleled, the Pins above are internally shorted.

3.3.2 Active Current Share:

For a required output to A.C.S please connect the following Pins between the two units

- PO#_Sense & PO#_Sense_RTN
- PO#_SHARE
- PO#_ACS

Note: if two outputs of a unit are configured as paralleled, the Pins above are internally shorted

Typical ACS Dynamic Load of Two 12V Paralleled Outputs

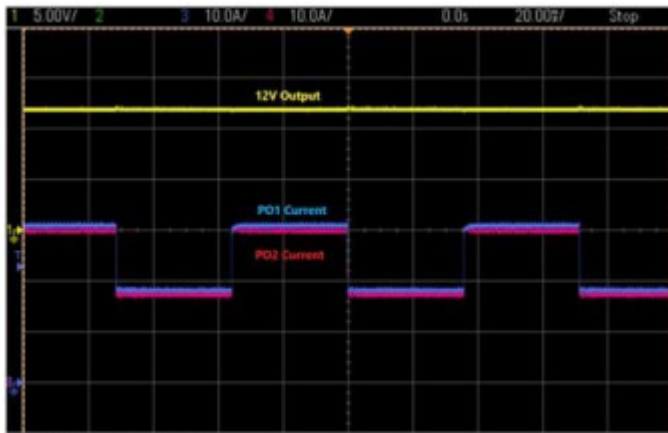

Note

1: When Not used, A.C.S can be left open. When ordering P.C.S or Non-Current Share unit, those pins are Internally disconnected

4. IPMI Protocol

Electrical Parameters

Vcc: 3.3VDC

Pull-up: 2.2kOhm Input capacitance: 100pf

Slave Device Addressing

- 256 address spaces
- Baud rate: 200kHz maximum
- 7 Bit Protocol
- Support Slot Addressing per VITA62
- Support Global Address 10100101 R/W

Slot Number	MSB							LSB
	A6	A5/*GAP	A4/*GA41	A3/*GA3	A2/*GA2	A1/*GA1	A0/*GA0	R/W
Slot0	1	0	0	0	0	0	0	
Slot1	1	0	0	0	0	0	1	
Slot2	1	0	0	0	0	1	0	
Slot3	1	0	0	0	0	1	1	
General Call	1	0	1	0	1	0	1	

Communication Supported

Read Command – 21Hex, deliver 64Bytes of Data. (More commands are available by request)

The communication starts when the master sends a start followed by the unit slave address, command, checksum and a stop. A second start followed by the slave address and a read will be followed by a 64 Bytes response.

S	Slave Address	R/W	A	Command	A	Check sum	A	P
	A6:A0	0	0	21 Hex	0	DF Hex	0	

S	Slave Address	R/W	A	DATA	A	DATA	A	DATA	A	...	DATA	A	Check sum	N/A	P
	A6:A0	1	0	D7:D0	0	D7:D0	0	D7:D0	0		D7:D0	0	D7:D0	1	

Command – 21Hex read all 64 Bytes

S - Start

P - Stop

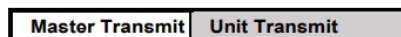

MEMORY SPACE

Response Byte #	Data Type	Meaning	Interpretation	Reading Range
0	U Integer, MSB First	Echo of Command		21 Hex
1	U Integer, MSB First	N/A		00 Hex
2	S Integer, MSB First	Temperature	T(C°)=+/- 7bit Dec	-55 C° to 125 C°
3	U Integer, MSB First	Reserved	00Hex	
4-5	U Integer, MSB First	VS1 Voltage	V(out) = Data/ m2	20.48V
6-7	U Integer, MSB First	VS2 Voltage	V(out) = Data/ m2	20.48V
8-9	U Integer, MSB First	VS2 Voltage	V(out) = Data/ m2	20.48V
10-11	U Integer, MSB First	3.3V Aux Voltage	V(out) = Data/ m2	20.48V
12-13	U Integer, MSB First	12V Aux Voltage	V(out) = Data/ m2	20.48V
14-15	U Integer, MSB First	(-)12V Aux Voltage	V(out) = Data/ m2	20.48V
16-17	U Integer, MSB First	12V VS1 Current	V(out) = Data/ m3	40A
18-19	U Integer, MSB First	3.3V VS2 Current	V(out) = Data/ m3	40A
20-21	U Integer, MSB First	5V VS2 Current	V(out) = Data/ m3	40A
22-23	U Integer, MSB First	3.3V Aux Current	V(out) = Data/ m5	20A
24-35	U Integer, MSB First	12V Aux Current	V(out) = Data/ m4	10A
26-27	U Integer, MSB First	(-)12V Aux Current	V(out) = Data/ m4	10A
28-29	U Integer, MSB First	Reserved	00Hex	
30-31	U Integer, MSB First	Reserved	00Hex	
32-51	Character String (ASCII)	Part Number	M4067-1 (Note1)	20 Characters
52-53	Decimal, MSB First	Serial Number, 2MSB Dig	X,X Dec TBD (Note2)	N/A
54-55	Decimal, MSB First	Serial Number, 2LSB Dig	X,X Dec (Note2)	N/A
56-57	Decimal, MSB First	Date Code	Week, Year (Note3)	N/A
58-59	Character String (ASCII)	Hardware Rev	B01 & B02 Boards (Note4)	2 Characters
60-61	Decimal, MSB First	Firmware Rev	X,X,X,X Dec (Note5)	4 digits
62	U Integer, MSB First	Reserved		AA Hex
63	U Integer, MSB First	Zero Checksum	Value required to make the sum of bytes 0 to 62 added to a multiple of 256	

Notes 1 to 5:

1. Part Number Example: M4065-4

Byte No'	32	33	34	35	36	37	38	39-51
Character	M	4	0	6	5	(-)	4	0
Hex	4D	34	30	36	35	2D	34	00

2. Serial Number Example: 25

Byte No'	52		53		54		55	
Dec Number	0	0	0	0	0	0	2	5
Binary	"0000"	"0000"	"0000"	"0000"	"0000"	"0000"	"0010"	"0101"

3. Date Code Example: week 35 of 2018

Byte No'	56		57	
Dec Number	3	5	1	8
Binary	"0011"	"0101"	"0001"	"1000"

4. Hardware Rev Example: B01 Rev (-), B01 Rev A

Byte No'	58	59
Character	(-)	A
Hex	2D	41

5. Firmware Rev Example: 2.1.0.0

Byte No'	60		61	
Dec Number	2	1	0	0
Binary	"0010"	"0001"	"0000"	"0000"

PIN ASSIGNMENT:

Connector P0
 Connector type: 6450843-6 or eq.

Pin Number	Signal Name
P7	PHASE A
P6	PHASE B
P5	PHASE C
P4	NEUTRAL
P3	
P2	
P1	CHASSIS_GND

Connector P1:
 Connector type: 6450849-6 or eq.

Pin Number	Pin Name
P10	12V/35A PO1
P9	12V35A PO2
A9	PO1_SENSE
B9	PO2_SENSE
C9	PO3_SENSE
D9	(-)-CLK
A8	PO1_SENSE_RTN
B8	PO2_SENSE_RTN
C8	PO3_SENSE_RTN
D8	+CLK
A7	PO1_SHARE
B7	PO2_SHARE
C7	PO3_SHARE
D7	SIGNAL_RETURN
P8	POWER_RETURN
P7	POWER_RETURN
A6	+CLK
B6	-CLK
C6	-12V_AUX
D6	SYSRESET*
A5	GAP*
B5	GA4*
C5	SCL
D5	SDA
A4	GA3*
B4	GA2*
C4	GA1*
D4	GA0*
A3	VS1 ACS /N.C
B3	+12V_AUX
C3	N.C
D3	N.C
P6	5V/40A PO3
P5	5V/40A PO3
P4	POWER_RETURN
P3	POWER_RETURN
A2	N.C
B2	FAIL*
C2	INHIBIT*
D2	ENABLE*
A1	3.3Vaux Sense
B1	3.3Vaux Sense return
C1	VS3 ACS/N.C
D1	VS2 ACS/N.C
P2	3.3V/15A
P1	POWER_RETURN

Outline Drawing

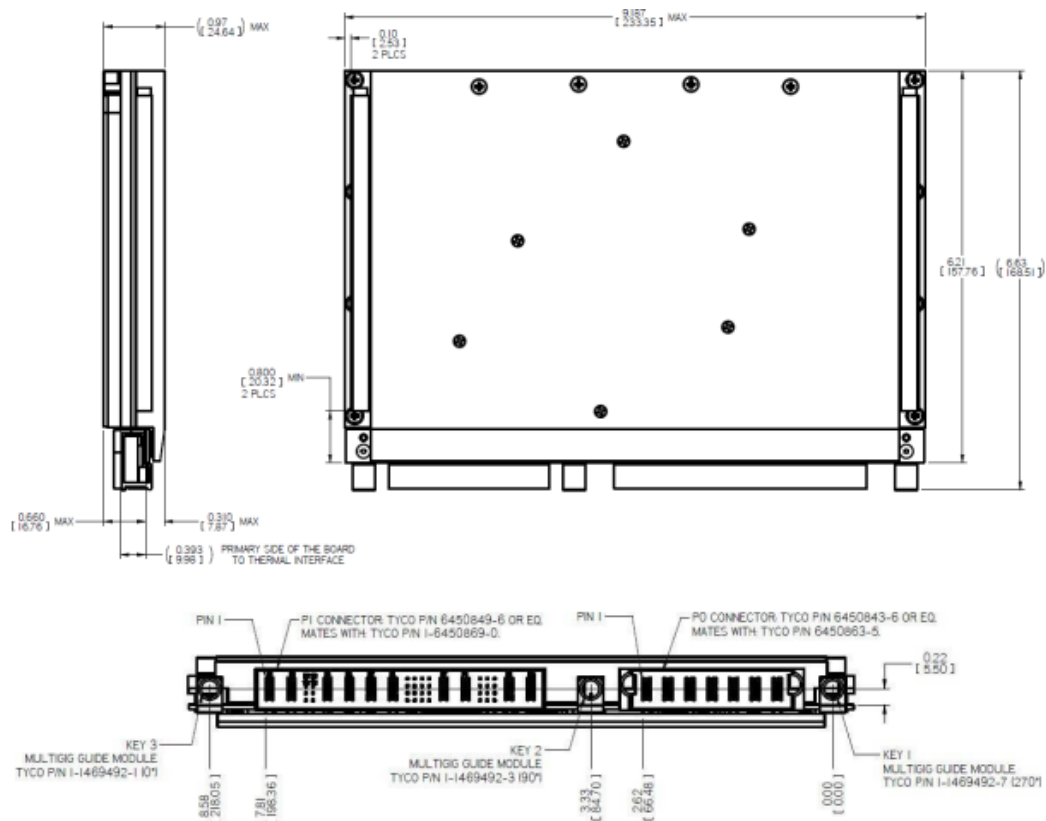

Notes

1. Dimensions are in Inches[mm]
2. Tolerance is:
 .XX ± 0.01 IN
 .XXX ± 0.005 IN
3. Weight: Approx. 4 lbs

Notice: Specifications are subject to change without notice. Contact your nearest Amphenol Corporation Sales Office for the latest specifications. All statements, information and data given herein are believed to be accurate and reliable but are presented without guarantee, warranty, or responsibility of any kind, expressed or implied. Statements or suggestions concerning possible use of our products are made without representation or warranty that any such use is free of patent infringement and are not recommendations to infringe any patent. The user should assume that all safety measures are indicated or that other measures may not be required. Specifications are typical and may not apply to all connectors.

AMPHENOL is a registered trademark of Amphenol Corporation.
 PRELIMINARY

©2023 Amphenol Corporation REV:



40-60 Delaware Avenue
 Sidney, NY 13838
 amphenol-aerospace.com | amphenolmao.com