

## M7027 SERIES

### DC/DC POWER SUPPLY



#### DESCRIPTION

The M7027 military power supply is a rugged DC to DC converter which accepts an 18 - 48VDC input voltage range and provides a single DC output from 5 to 50V at up to 500W. Custom outputs available upon request and the unit is Designed to meet military standards, MIL-STD-704, MIL-STD-1275, MIL-STD-810, MIL-STD-461.

#### FEATURES

- Wide input range
- Input / Output isolation
- High efficiency – up to 90%
- High Density – up to 47 W/in<sup>3</sup>
- EMI filters included
- Remote sense compensation
- Parallel connection option
- Remote sense compensation
- Parallel connection option
- Fixed switching freq. (250kHz)
- External sync. capability
- Remote inhibit (on/off)
- Non-latching protections:
  - o Overload / short-circuit
  - o Input OV/UV lockout
  - o Output over-voltage
  - o Over temperature

## HOW TO ORDER

PART NUMBER	INPUT VOLTAGE RANGE	OUTPUT VOLTAGE   CURRENT
CF-	18 TO 48 VDC	5 VDC / 40 A
CF-	18 TO 48 VDC	12 VDC / 40 A
CF-	18 TO 48 VDC	15 VDC / 33 A
CF-	18 TO 48 VDC	24 VDC / 21 A
CF-	18 TO 48 VDC	28 VDC / 18 A
CF-	18 TO 48 VDC	48 VDC / 10.5 A
CF-	18 TO 48 VDC	28 VDC / 20 A

## ELECTRICAL SPECIFICATIONS

<p><b>DC Input:</b> 18 to 48 VDC, Extended input range option: 18 to 100 VDC IAW MIL-STD-1275E</p>	<p><b>DC Output:</b> Voltage range: 5 to 50 VDC Current range: 0 to 40 A Power range: 0 to 500 W Peak power: Up to 750 W for up to 4 seconds. After 4 seconds, the output falls to 70% from its nominal value.</p>	<p><b>Isolation:</b> 200V between Input and Output 200V between Input and Case 100V between Output and Case</p>
<p><b>Transient protection:</b> IAW MIL-STD-1275A, MIL-STD-704A (no operation, no damage)</p>		<p><b>EMC:</b> Design to Meet* MIL-STD-461F CE101, CE102, CS101, CS114, CS115, CS116, RE101, RE102, RS101, RS103</p>
<p><b>Output Voltage Regulation:</b> Up to <math>\pm 1\%</math> (no load to full load, <math>-55^{\circ}\text{C}</math> to <math>+85^{\circ}\text{C}</math>, a)</p>	<p><b>Efficiency:</b> Typical: 88% - 90% Extended input range: 83% - 86% (28VDC output, nominal input, full load, room temperature)</p>	<p><b>Turn on Transient:</b> No Voltage over shoot during power on.</p>
<p><b>Ripple and Noise:</b> Less than 50 mVp-p, typical (max. 1% of output voltage) without external capacitance. When connected to system capacitance ripple drops significantly.</p>	<p><b>Transient Over-and undershoot:</b> Output change at load transient of 30 to 100% with <math>T_r</math> &amp; <math>T_f</math> of max 30 <math>\mu\text{s}</math> is 5% of output voltage. Output recover to steady state within less 0.5 ms</p>	

## PROTECTIONS

Input	Output	General
<b>Isolation:</b> Input Reverse Polarity: Protection for unlimited time	<b>Active Over-Voltage Protection:</b> Secondary control circuit takes over if output voltage exceeds $110\% \pm 5\%$ of nominal voltage.	<b>Over Temperature Protection:</b> Output shuts down if base plate temperature exceeds $+105^{\circ}\text{C} \pm 5^{\circ}\text{C}$ . Automatic recovery when baseplate temperature returns to below $+95^{\circ}\text{C} \pm 5^{\circ}\text{C}$ .
<b>Under-Voltage LockOut:</b> Unit shuts down below $15\text{V} \pm 1\text{V}$ . Resumes operation at $17\text{V} \pm 1\text{V}$ . Min. hysteresis 2V.	<b>Passive Over-Voltage Protection:</b> Zener diode installed on output terminals, selected at $120\% \pm 10\%$ of nominal voltage.	POR: Protection Override signal (BATTLE SHORT function) overrides over temperature protection and input over/under-voltage lock-out.
<b>Over-Voltage Lock-Out:</b> Unit shuts down above $54\text{V} \pm 2\text{V}$ .	<b>Peak Load Duration Limiter:</b> Peak load is enabled for up to 4 seconds. Beyond this, output voltage folds to limit the output power to the nominal value.	
	<b>Short Circuit Protection:</b> Output voltage turns off and on periodically with low duty-cycle (hiccup) to protect system conductors and converter from short circuit.	

## ENVIRONMENTAL CONDITIONS

Meets MIL-STD-810F

<b>Temperature:</b> Operating: $-55^{\circ}\text{C}$ to $+85^{\circ}\text{C}$ (at baseplate) Storage: $-55^{\circ}\text{C}$ to $+125^{\circ}\text{C}$	<b>Altitude:</b> Method 500.4, Procedure I & II, 40,000 ft. and 70,000 ft. Operational	<b>Salt Fog:</b> Method 509.4
<b>Humidity:</b> Method 507.4 Procedure I Up to 95% RH	<b>Vibration:</b> Method 514.5 Category 24 – General minimum integrity exposure IAW Figure 514.5C-17 1 hour per axis.	<b>Shock:</b> Method 516.5 Procedure I – Functional shock Saw-tooth, 30g peak, 11 ms

## EFFICIENCY PLOTS

28 VDC variant:

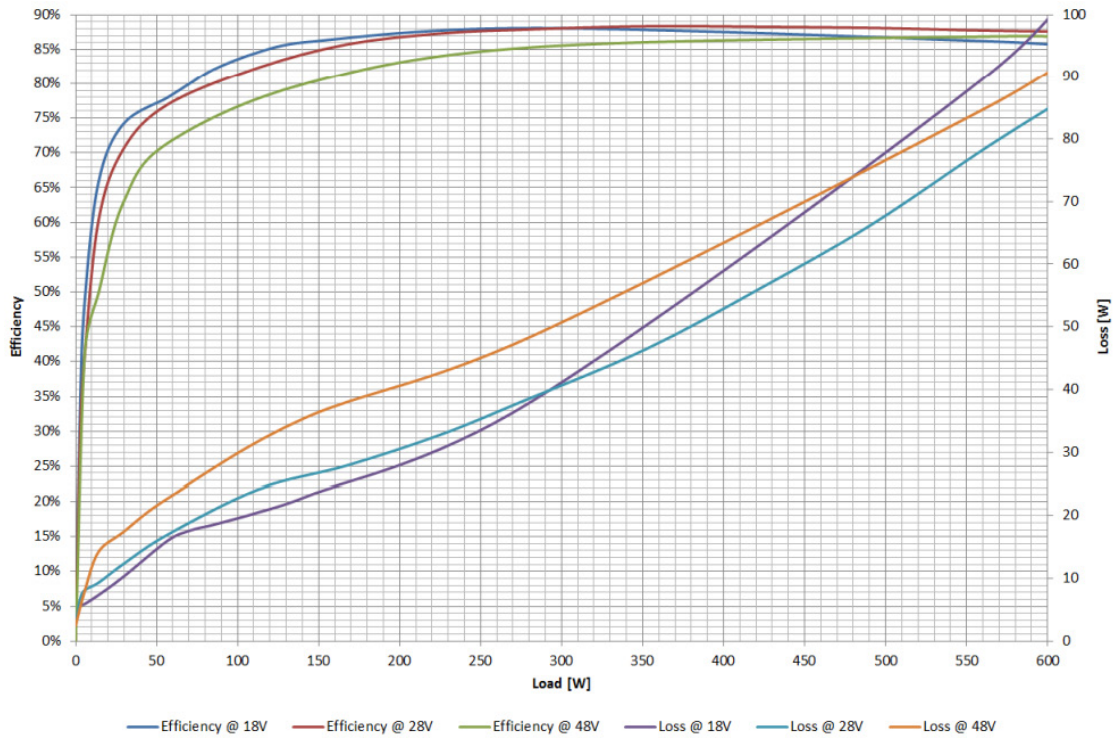

50 VDC variant:

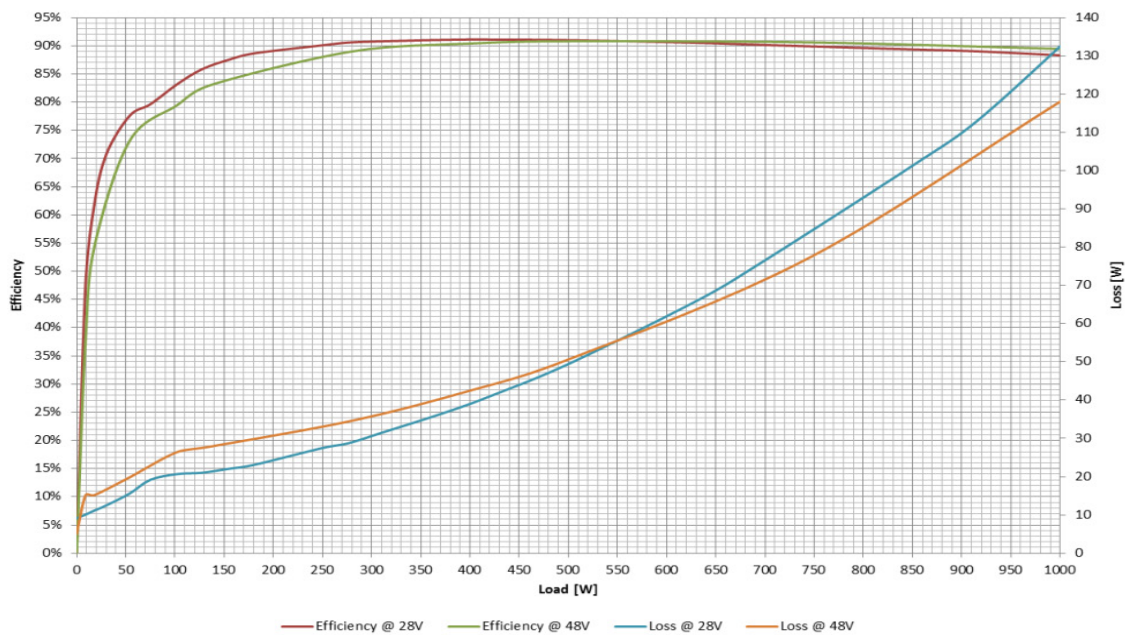

## PIN ASSIGNMENT

Connector type: M24308/24-34F or eq.

Mates with: M24308/2-4F or eq.

Pin No.	Function	P	
1	SENSE	+	●
2	OUT	+	●
3	OUT	+	●
4	OUT	+	●
5	OUT RTN	-	●
6	OUT RTN	-	●
7	OUT RTN	-	●
8	OUT RTN	-	●
9	SENSE RTN	-	
10	N.C.		
11	INHIBIT		
12	IN	+	●
13	IN	+	●

Pin No.	Function	P	
14	IN RTN	-	●
15	IN RTN	-	●
16	N.C.		
17	N.C.		
18	N.C.		
19	N.C.		
20	OUT	+	●
21	OUT	+	●
22	OUT	+	●
23	OUT	+	●
24	OUT	+	●
25	OUT RTN	-	●
26	OUT RTN	-	●

Pin No.	Function	P	
27	OUT RTN	-	●
28	OUT RTN	-	●
29	SYNC IN		
30	IN	+	●
31	IN	+	●
32	IN	+	●
33	IN RTN	-	●
34	IN RTN	-	●
35	IN RTN	-	●
36	POR	+	
37	SIGNAL RTN	-	

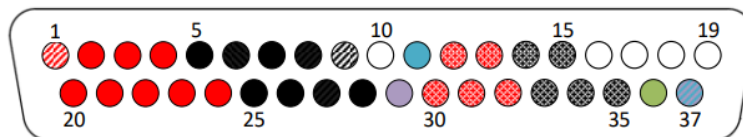

## FUNCTIONS AND SIGNALS

### INHIBIT

The INHIBIT signal is used to turn the power supply ON and OFF.  
To turn the power supply OFF, apply a TTL “0” signal or SHORT to SIGNAL RTN.  
To turn the power supply ON, apply a TTL “1” signal or leave this pin OPEN.  
If not used (always ON), leave this pin OPEN.  
This signal is referenced to SIGNAL RTN.

### SYNC IN

The SYNC IN signal is used to allow the power supply frequency to sync with the system frequency.  
The system frequency should be 250 kHz  $\pm$  10 kHz.  
When not connected the power supply will work at 250 kHz  $\pm$  10 kHz.  
This signal is referenced to SIGNAL RTN.

### POR (Protection Override)

The POR signal disables the input under voltage lockout, input over voltage lockout, over temperature protection and peak load duration limiter.  
TTL “0” or short to SIGNAL RTN – Protections are disabled (BATTLE SHORT mode).  
TTL “1” or open circuit – Protections are enabled (Protected mode).  
For normal protected operation, leave this pin OPEN.  
This signal is referenced to SIGNAL RTN.

### SIGNAL RTN

The SIGNAL RTN is referenced to IN RETURN.  
This is used as grounding for SYNC IN, INHIBIT and POR signals.

### SENSE

The SENSE is used to achieve accurate load regulations at load terminals (this is done by connecting the pins directly to the load’s terminals). The use of remote sense has a limit of voltage dropout between converter’s output and load terminals up to 0.5V.  
When not used connect SENSE to OUT and SENSE RTN to OUT RTN.

## TYPICAL CONNECTION DIAGRAM

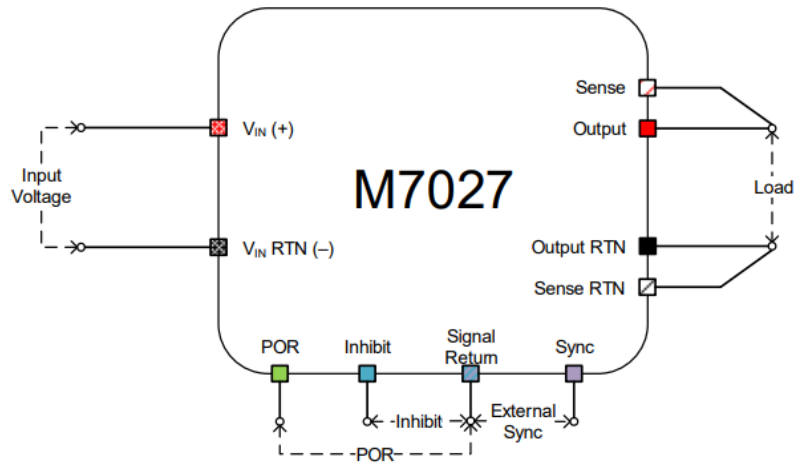

## PARALLEL OPERATION- TYPICAL CONNECTION DIAGRAM

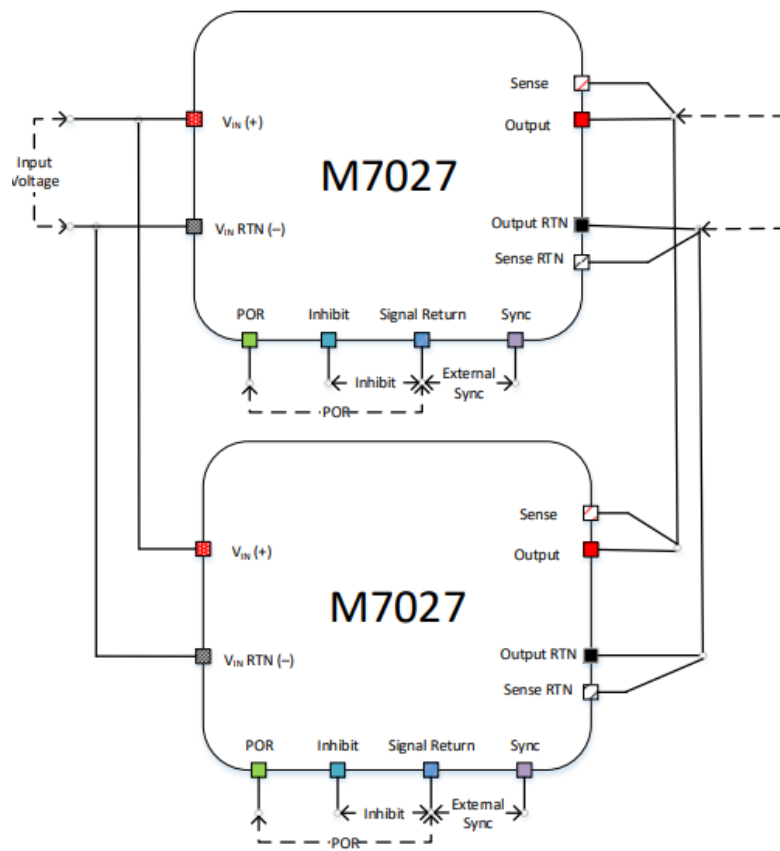

## OUTLINE DRAWING

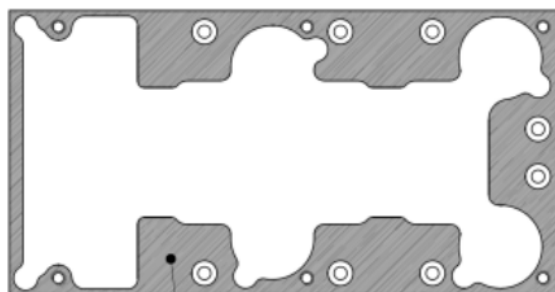
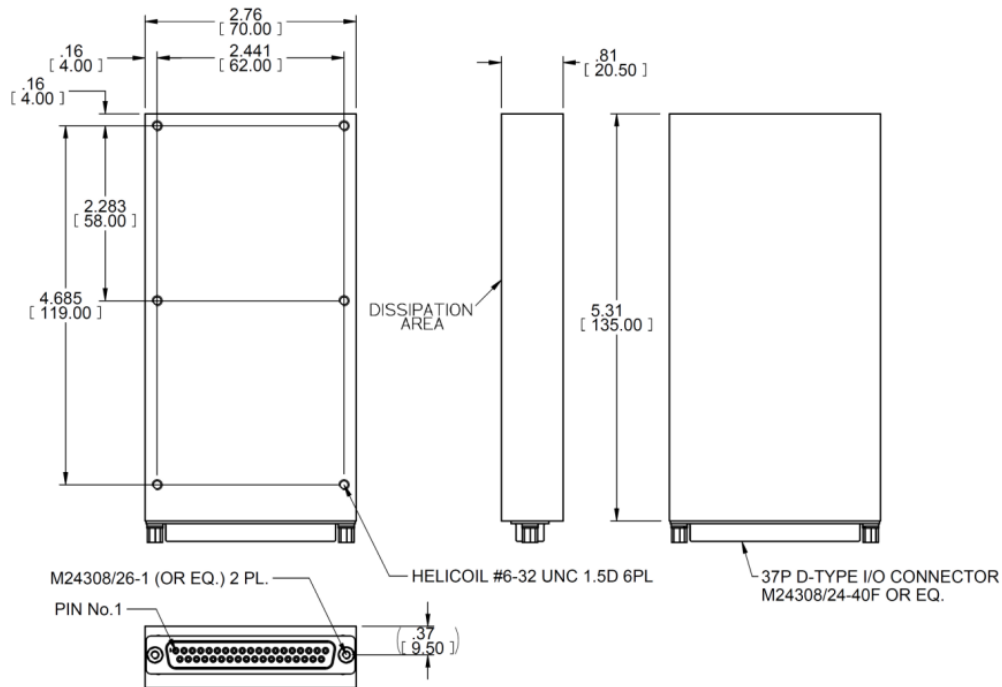

### Notes

1. Dimensions are in inches [mm]
2. Tolerance is:  
 .XX ± 0.02 in  
 .XXX ± 0.008 in
3. Weight: Approx. 14.1 oz  
 [400 g]

Notice: Specifications are subject to change without notice. Contact your nearest Amphenol Corporation Sales Office for the latest specifications. All statements, information and data given herein are believed to be accurate and reliable but are presented without guarantee, warranty, or responsibility of any kind, expressed or implied. Statements or suggestions concerning possible use of our products are made without representation or warranty that any such use is free of patent infringement and are not recommendations to infringe any patent. The user should assume that all safety measures are indicated or that other measures may not be required. Specifications are typical and may not apply to all connectors.

AMPHENOL is a registered trademark of Amphenol Corporation.  
 PRELIMINARY

©2023 Amphenol Corporation REV:



40-60 Delaware Avenue  
 Sidney, NY 13838  
[amphenol-aerospace.com](http://amphenol-aerospace.com) | [amphenolmao.com](http://amphenolmao.com)