

M7242 SERIES

AC+DC-DC POWER SUPPLY



DESCRIPTION

The M7242 Series is a versatile power supply solution designed to handle both AC and DC inputs with ease. It offers a universal AC input and a wide range DC input with in-rush current limiting for both AC and DC inputs. The M7242 Series also supports remote inhibit functionality for convenient on/off control and comes equipped with EMI filters to minimize electromagnetic interference. The Hot Switch-Over feature ensures continuous operation during input failure, while non-latching protections safeguard against overloads, short-circuits, over-voltage, and over-temperature conditions.

FEATURES

- Universal AC Input
- Wide range DC Input
- High efficiency
- High power factor
- Inrush current limiting (AC & DC)
- Remote inhibit (ON/OFF)
- EMI filters included
- Hot Switch-Over on Input Failure
- Non-latching protections:
 - Overload/short-circuit
 - Over-voltage protection
 - Over temperature

HOW TO ORDER

Part Number	Input		Output	
	Dc Input	AC Input	Voltage	Current
CF-02EM7242-1	12 to 36 VDC	85-265 VAC /50/60/400Hz/ Single phase	12 VDC	20 A
CF-02EM7242-2	12 to 36 VDC	85-265 VAC /50/60/400Hz/ Single phase	15 VDC	20 A
CF-02EM7242-3	12 to 36 VDC	85-265 VAC /50/60/400Hz/ Single phase	24 VDC	20 A
CF-02EM7242-4	12 to 36 VDC	85-265 VAC /50/60/400Hz/ Single phase	28 VDC	18 A

PRODUCT SPECIFICATIONS:

AC INPUT	
Voltage range:	85 to 265 VAC
Frequency range:	50 to 400 Hz Single-Phase
OUTPUT	
Voltage range:	12 to 36 VDC
Current:	Up to 20 A
Power:	Up to 500 W
EFFICIENCY	
AC input:	Typical 90%, Min 85%
DC input:	Typical 93%, Min 85%
(Full load, nominal line voltage, room temperature)	
Parallel Capability-Optional	Multiple identical units of M7242 can be connected in parallel- Please consult factory for details.
DC INPUT	
Voltage Range:	12 to 36 VDC
Surge protection:	80 V / 0.1 s IAW MIL-STD-704A
Surge operation:	100V / 50ms IAW MIL-STD-1275E

OUTPUT VOLTAGE REGULATION	
Up to $\pm 3\%$ (Low to high linevoltage, no load to full load, -40°C to $+85^{\circ}\text{C}$).	
Transient Over-and-undershoot	
Load step from 50% to 100% output voltage change less than 10% within 200-300 μs	
Isolation	
AC input to output:	1000 VDC
AC input to DC input:	1000 VDC
AC input to Chassis:	1000 VDC
DC input to Chassis:	100 VDC
Output to Chassis:	100 VDC
DC input is not isolated from output	
Ripple and Noise	
Typically better than 100 mV (max. 1%) without external capacitance. When connected to system capacitance ripple drops significantly.	
Turn on Transient	
No output voltages overshoot during startup.	
Parallel Capability-Optional	
Multiple identical units of M7242 can be connected in parallel- Please consult factory for details	

Protections (Input)	
Inrush Current Limiter	Peak value of up to twice IIN for AC and DC Inputs.
Under Voltage Lock-Out	Unit shuts down (no damage) below 75 VAC or 10 VDC.
Surge operation:	100V / 50ms IAW MIL-STD-1275E
AC input to output:	1000 VDC
Protections (Output)	
Active Over Voltage Protection	Internal control protects unit (no damage) $\sim 10\%$ above nominal voltage.
Passive Over Voltage Protection	Transorbs on outputs protect loads $\sim 20\%$ above nominal voltage
Overload/Short Circuit Protection	Continuous protection (10-50% above maximum current) for unlimited time (Hiccup).
Protections (General)	
Over Temperature Protection	Shutdown at base plate temperature of $+105^{\circ}\text{C} \pm 5^{\circ}\text{C}$. Automatic recovery at base plate temperature lower than $+90^{\circ}\text{C} \pm 5^{\circ}\text{C}$.

ENVIRONMENTAL CONDITIONS	
Designed to meet or exceed MIL-STD-810F	
Temperature	Operating: -40°C to +85°C (base plate) Storage: -55°C to +125°C
Humidity	Method 507.4 - Up to 95%.
Altitude	Method 500.4 Procedure I – up to 70,000 ft. Procedure II – up to 30,000 ft.
Vibration	Figure 514.5C-17. General minimum integrity exposure. (1 hour per axis.)
Salt Fog	Method 509-4
Shock	Saw-tooth, 20g peak, 11 ms
EMC	CE102 CS101 CS114 CS115 CS116 RS101 RS103
Reliability	150,000 hours, calculated IAW MIL-HDBK-217F Notice 2 at +85°C baseplate, Ground Fixed environment.

FUNCTION AND SIGNALS:

Output ON/OFF Control (Connector J3, Pins #1 and #2)

Connecting these pins together toggles the output ON or OFF, based on the following conditions:

- PSU will turn OFF when the output is currently ON and the connection of these control pins lasts for more than 3 seconds.
- The PSU will turn ON when the output is currently OFF and the connection of these control pins lasts for more than 100 ms seconds.
- To eliminate unwanted output toggling (if an external button is pushed too long) the PSU ignores additional change requests until the pins have been disconnected for 1 second.

(a continuous SHORT/OPEN version can be implemented – consult factory).

Temperature Warning (Connector J3, Pins #3 and #5)

These pins are used to indicate when the unit is within 20 °C of the maximum temperature prior to execution of automatic thermal shutdown.

This signal can be used by an external monitoring system to indicate when the unit is operating fairly close to the thermal shut down temperature.

- This interface is isolated from any internal electronic connection or grounds.
- These pins are shorted together (CLOSED condition) when the baseplate temperature is within 20°C of the thermal shutdown threshold.
The connection's resistance is 50 Ω or less, measured across these pins.
The connection is capable of handling at least 40 mA from an external source in this condition
- These pins are disconnected (OPEN condition) when the baseplate temperature is below 20 °C of the thermal shutdown threshold.
The connection resistance is higher than 100 k Ω measured across these pins.

Thermal Shutdown Warning (Connector J3, Pins #4 and #5)

These pins are used to indicate when the unit is within 10 °C of the maximum temperature prior to execution of automatic thermal shutdown.

This signal can be used by an external monitoring system to indicate when the unit is operating fairly close to the thermal shut down temperature.

- This interface is isolated from any internal electronic connection or grounds.
- These pins are shorted together (CLOSED condition) when the baseplate temperature is within 10°C of the thermal shutdown threshold.
The connection's resistance is 50 Ω or less, measured across these pins.
The connection is capable of handling at least 40 mA from an external source in this condition
- These pins are disconnected (OPEN condition) when the baseplate temperature is below 10 °C of the thermal shutdown threshold.
The connection resistance is higher than 100 k Ω measured across these pins.

PIN ASSIGNMENT:

DC Input (Connector J1)

Connector type: Positronic CBM8W8M75000S/AA or eq.

Mating connector type: Positronic CBM8W8S0000S/AA (contacts ordered separately) or eq.

Pin #	Function	Polarity
A1	DC Input	+
A2	DC Input	+
A3	DC Input	+
A4	DC Input	+

Pin #	Function	Polarity
A5	DC Input RTN	-
A6	DC Input RTN	-
A7	DC Input RTN	-
A8	DC Input RTN	-

AC Input (Connector J2)

Connector type: Positronic CBM3W3M75000S/AA or eq.

Mating connector type: Positronic CBM3W3S0000S/AA (contact ordered separately) or eq.

Pin #	Function
A1	AC Line
A2	AC Neutral
A3	AC GND

DC Output & Control (Connector J3)

Connector type: Positronic CBM9W4S75000S/AA or eq.

Mating connector type: Positronic CBM9W4M2000S/AA or eq.

Pin #	Function	Polarity
A1	Output	+
A2	Output	+
A3	Output RTN	-
A4	Output RTN	-

Pin #	Function
1	Output ON/OFF Control
2	Output ON/OFF Control RTN
3	Thermal Shutdown Warning
4	Temperature Warning
5	Warning Signals RTN

FUNCTIONAL BLOCK DIAGRAM:

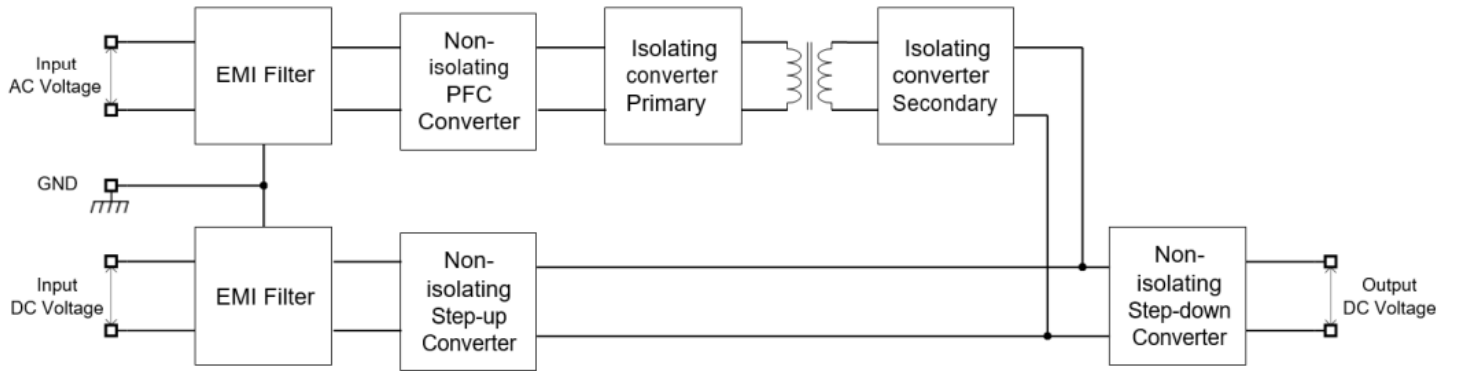

TYPICAL CONNECTION DIAGRAM:

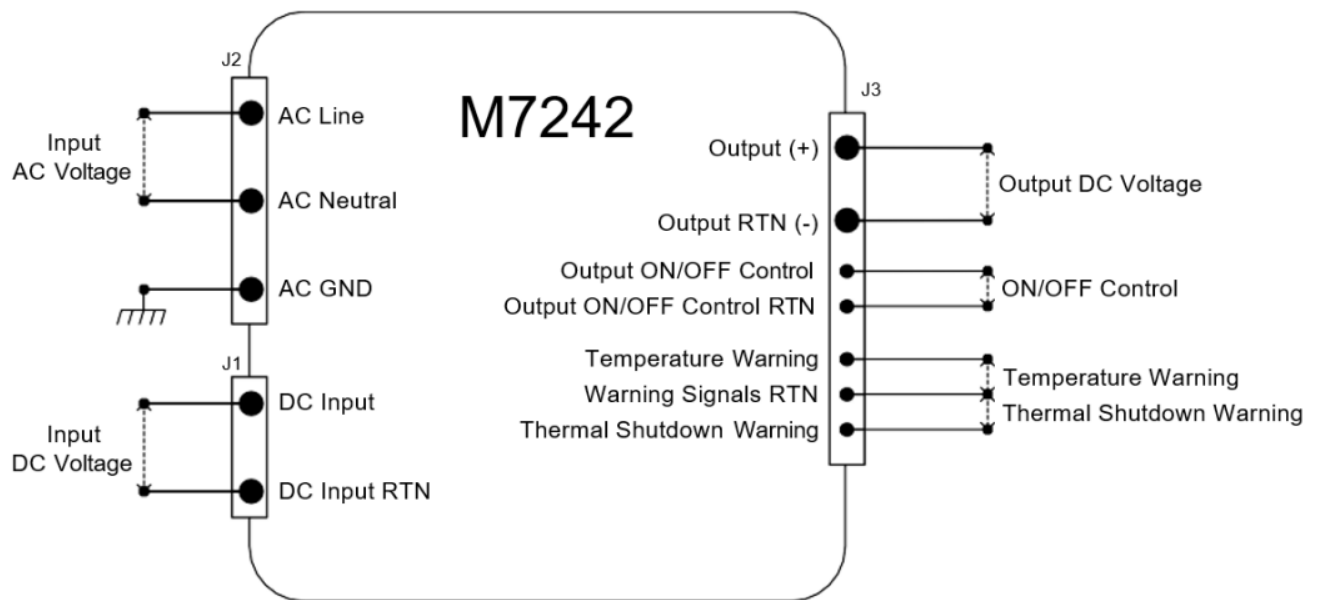

OUTLINE DRAWING:

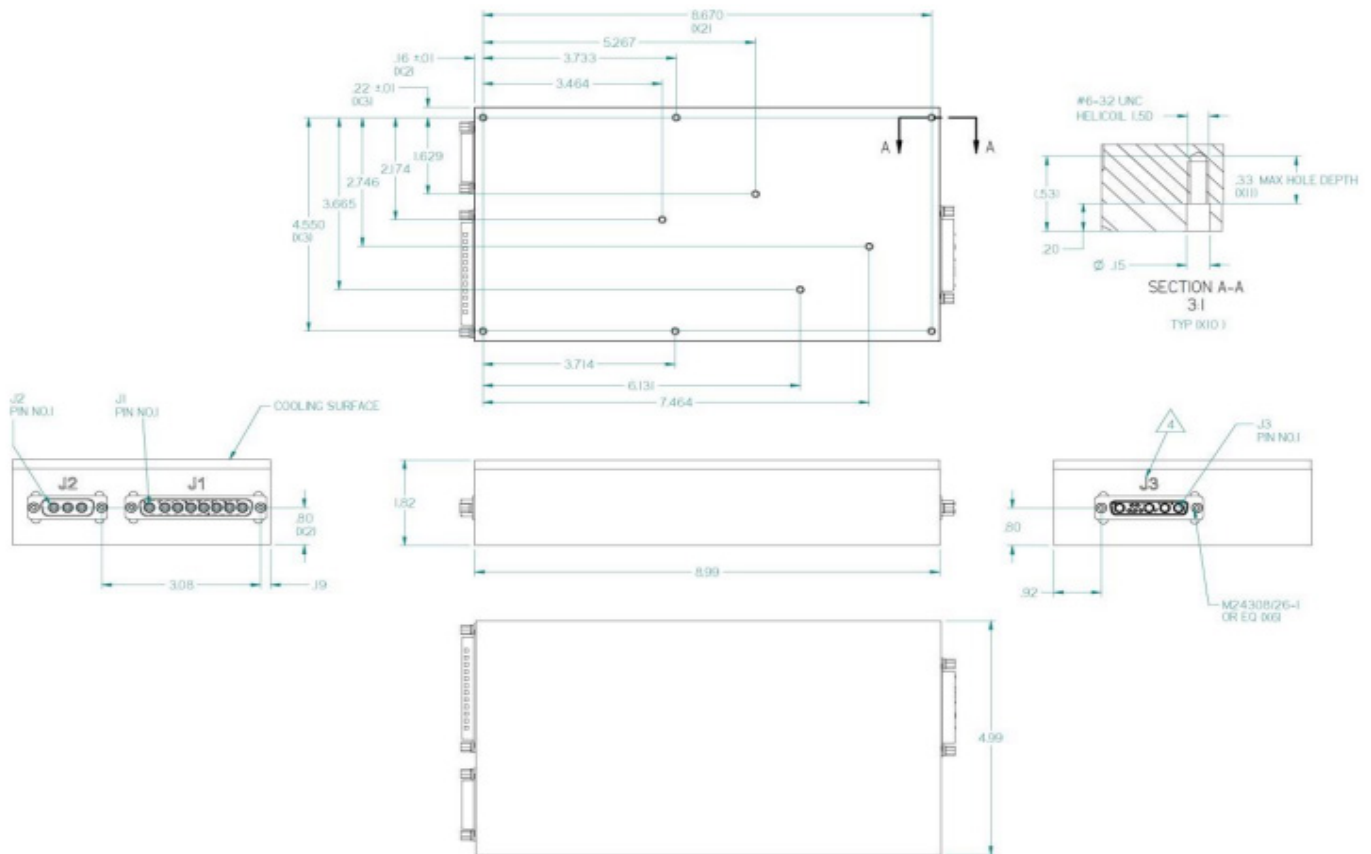

Notes

1. Dimensions are in inches
2. Tolerances are:
 .XX ± 0.02 in
 .XXX ± 0.005 in
3. Weight: 4.63 lbs (2.1 kg) max.

Notice: Specifications are subject to change without notice. Contact your nearest Amphenol Corporation Sales Office for the latest specifications. All statements, information and data given herein are believed to be accurate and reliable but are presented without guarantee, warranty, or responsibility of any kind, expressed or implied. Statements or suggestions concerning possible use of our products are made without representation or warranty that any such use is free of patent infringement and are not recommendations to infringe any patent. The user should assume that all safety measures are indicated or that other measures may not be required. Specifications are typical and may not apply to all connectors.

AMPHENOL is a registered trademark of Amphenol Corporation.
 PRELIMINARY

©2023 Amphenol Corporation REV:



40-60 Delaware Avenue
 Sidney, NY 13838
amphenol-aerospace.com | amphenolmao.com